

GB E P

Operating manual

Instrucciones de uso.....p. 22

Manual de proprietário...p. 44



Advanced Performance. Total Reliability.

Performance Series 460e

Airless high-pressure spraying unit

Airless Equipo de alta presión para pulverizar

Unidade de pulverização de alta pressão Airless

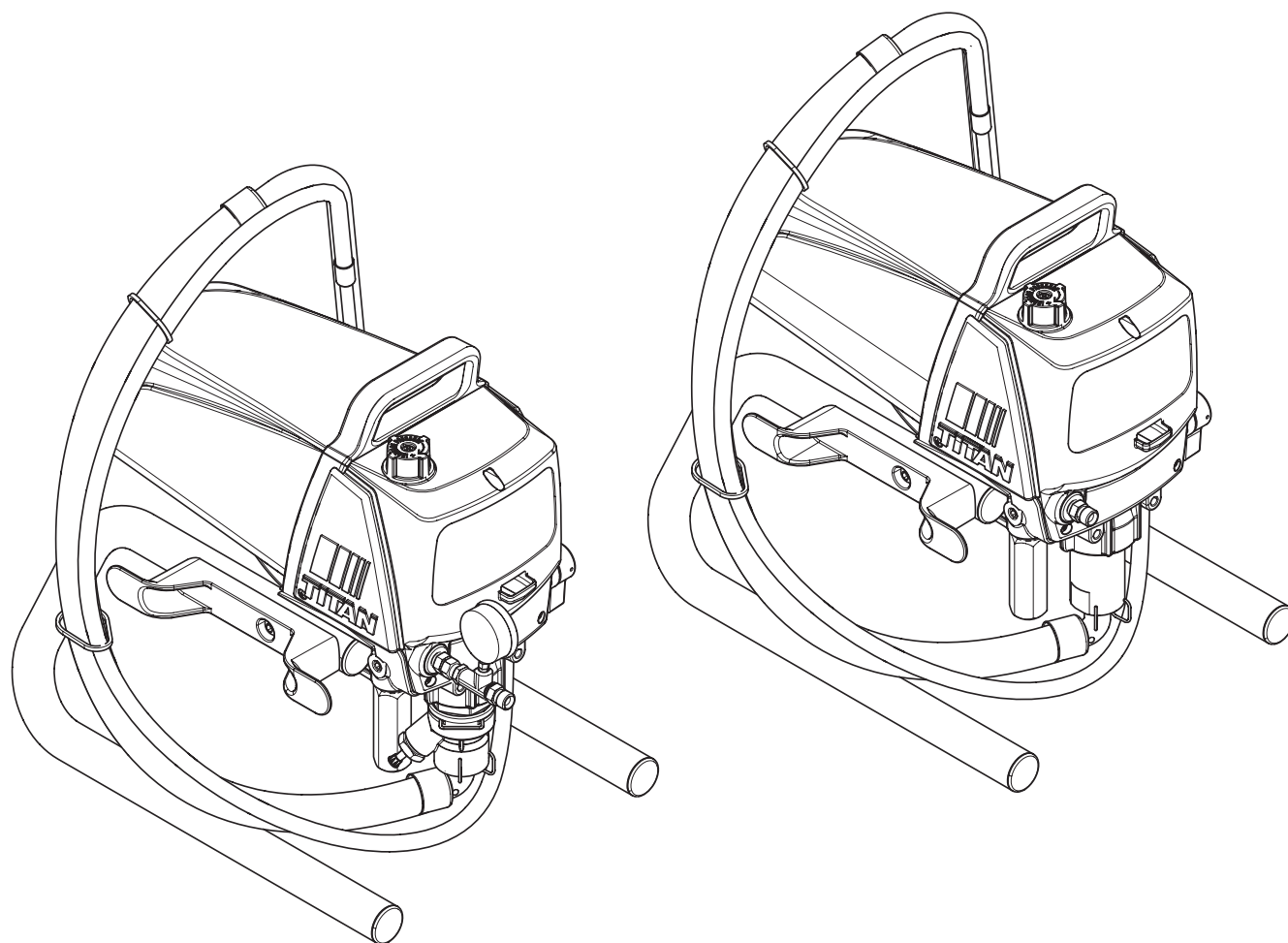

Warning!

Attention: Danger of injury by injection!
Airless units develop extremely high spraying pressures.

**1**

Never put your fingers, hands or any other parts of the body into the spray jet!

Never point the spray gun at yourself, other persons or animals.

Never use the spray gun without safety guard.

Do not treat a spraying injury as a harmless cut. In case of injury to the skin through coating materials or solvents, consult a doctor immediately for quick and expert treatment. Inform the doctor about the coating material or solvent used.

2

The operating instructions state that the following points must always be observed before starting up:

1. Faulty units must not be used.
2. Secure Titan spray gun using the safety catch on the trigger.
3. Ensure that the unit is properly earthed.
4. Check allowable operating pressure of high-pressure hose and spray gun.
5. Check all connections for leaks.

3

The instructions regarding regular cleaning and maintenance of the unit must be strictly observed.

Before any work is done on the unit or for every break in work the following rules must be observed:

1. Release the pressure from spray gun and hose.
2. Secure the Titan spray gun using the safety catch on the trigger.
3. Switch off unit.

Be safety conscious!







Contents

	Page		Page
1. Safety regulations for Airless spraying	2	9. Remedy in case of faults	10
1.1 Explanation of symbols used.....	2	10. Servicing	11
1.2 Electric safety.....	3	10.1 General servicing.....	11
1.3 Electrostatic charging (formation of sparks or flames).....	3	10.2 High-pressure hose.....	11
2. General view of application	4	11. Repairs at the unit	11
2.1 Application.....	4	11.1 Relief valve.....	11
2.2 Coating materials.....	4	11.2 Inlet and outlet valve.....	12
3. Description of unit	4	11.3 Packings.....	13
3.1 Airless process.....	4	11.4 Replacing the motor.....	14
3.2 Functioning of the unit.....	4	11.5 Replacing the gears.....	14
3.3 Legend for explanatory diagram Performance Series 460e....	5	11.6 Replacing the pressure switch / transducer.....	15
3.4 Explanatory diagram Performance Series 460e.....	5	11.7 Resetting the pressure switch timing.....	15
3.5 Technical data.....	6	11.8 Replacing the circuit board.....	16
3.6 Transportation in vehicle.....	6	11.9 Performance Series 460e connection diagram.....	17
4. Starting operation	6	12. Appendix	18
4.1 High-pressure hose, spray gun and separating oil.....	6	12.1 Selection of tip.....	18
4.2 Connection to the mains network.....	7	12.2 Servicing and cleaning of Airless hard-metal tips.....	18
4.3 Cleaning preserving agent when starting-up of operation initially.....	7	12.3 Spray gun accessories.....	18
4.4 Taking the unit into operation with coating material.....	7	12.4 Airless tip table.....	19/20
5. Spraying technique	8	12.5 TR ² Tip table.....	21
6. Handling the high-pressure hose	8	12.6 Additional accessories for 460e.....	21
7. Interruption of work	8	Spare parts lists	66
8. Cleaning the unit (shutting down)	9	Spare parts list for main assembly.....	66
8.1 Cleaning unit from outside.....	9	Spare parts list for suction system.....	67
8.2 Suction filter.....	9	Spare parts list for drive assembly I.....	68
8.3 Cleaning the high-pressure filter.....	9	Spare parts list for drive assembly II.....	70
8.4 Cleaning Airless spray gun.....	10	Spare parts list of stand.....	72
		Warranty	73

1. Safety regulations for Airless spraying

1.1 Explanation of symbols used

This manual contains information that must be read and understood before using the equipment. When you come to an area that has one of the following symbols, pay particular attention and make certain to heed the safeguard.

	This symbol indicates a potential hazard that may cause serious injury or loss of life. Important safety information will follow.
 Attention	This symbol indicates a potential hazard to you or to the equipment. Important information that tells how to prevent damage to the equipment or how to avoid causes of minor injuries will follow.
	Danger of skin injection
	Danger of fire from solvent and paint fumes
	Danger of explosion from solvent, paint fumes and incompatible materials
	Danger of injury from inhalation of harmful vapors
	Notes give important information which should be given special attention.



HAZARD: INJECTION INJURY

Attention: Danger of injury by injection! A high pressure stream produced by this equipment can pierce the skin and underlying tissues, leading to serious injury and possible amputation.

Do not treat a spraying injury as a harmless cut. In case of injury to the skin through coating materials or solvents, consult a doctor immediately for quick and expert treatment. Inform the doctor about the coating material or solvent used.

PREVENTION:

- NEVER aim the gun at any part of the body.
- NEVER allow any part of the body to touch the fluid stream. DO NOT allow body to touch a leak in the fluid hose.
- NEVER put your hand in front of the gun. Gloves will not provide protection against an injection injury.
- ALWAYS lock the gun trigger, shut the fluid pump off and release all pressure before servicing, cleaning the tip guard, changing tips, or leaving unattended. Pressure will not be released by turning off the engine. The PRIME/SPRAY valve or pressure bleed valve must be turned to their appropriate positions to relieve system pressure.
- ALWAYS keep tip guard in place while spraying. The tip guard provides some protection but is mainly a warning device.
- ALWAYS remove the spray tip before flushing or cleaning the system.
- NEVER use a spray gun without a working trigger lock and trigger guard in place.

- All accessories must be rated at or above the maximum operating pressure range of the sprayer. This includes spray tips, guns, extensions, and hose.



HAZARD: HIGH PRESSURE HOSE

The paint hose can develop leaks from wear, kinking and abuse. A leak can inject material into the skin. Inspect the hose before each use.

PREVENTION:

- High-pressure hoses must be checked thoroughly before they are used.
- Replace any damaged high-pressure hose immediately.
- Never repair defective high-pressure hoses yourself!
- Avoid sharp bends and folds: the smallest bending radius is about 20 cm.
- Do not drive over the high-pressure hose. Protect against sharp objects and edges.
- Never pull on the high-pressure hose to move the device.
- Do not twist the high-pressure hose.
- Do not put the high-pressure hose into solvents. Use only a wet cloth to wipe down the outside of the hose.
- Lay the high-pressure hose in such a way as to ensure that it cannot be tripped over.



Only use Titan original-high-pressure hoses in order to ensure functionality, safety and durability.



HAZARD: EXPLOSION OR FIRE

Solvent and paint fumes can explode or ignite. Severe injury and/or property damage can occur.

PREVENTION:

- Do not use materials with a flashpoint below 21° C (70° F). Flashpoint is the temperature at which a fluid can produce enough vapors to ignite.
- Do not use the unit in work places which are covered by the explosion protection regulations.
- Provide extensive exhaust and fresh air introduction to keep the air within the spray area free from accumulation of flammable vapors.
- Avoid all ignition sources such as static electricity sparks, electrical appliances, flames, pilot lights, hot objects, and sparks from connecting and disconnecting power cords or working light switches.
- Do not smoke in spray area.
- Place sprayer sufficient distance from the spray object in a well ventilated area (add more hose if necessary). Flammable vapors are often heavier than air. Floor area must be extremely well ventilated. The pump contains arcing parts that emit sparks and can ignite vapors.
- The equipment and objects in and around the spray area must be properly grounded to prevent static sparks.
- Use only conductive or earthed high pressure fluid hose. Gun must be earthed through hose connections.
- Power cord must be connected to a grounded circuit (electric units only).
- Always flush unit into separate metal container, at low pump pressure, with spray tip removed. Hold gun firmly against side of container to ground container and prevent static sparks.

- Follow material and solvent manufacturer's warnings and instructions. Be familiar with the coating material's MSDS sheet and technical information to ensure safe use.
- Use lowest possible pressure to flush equipment.
- When cleaning the unit with solvents, the solvent should never be sprayed or pumped back into a container with a small opening (bunghole). An explosive gas/air mixture can arise. The container must be earthed.



HAZARD: HAZARDOUS VAPORS

Paints, solvents, and other materials can be harmful if inhaled or come in contact with body. Vapors can cause severe nausea, fainting, or poisoning.

PREVENTION:

- Wear respiratory protection when spraying. Read all instructions supplied with the mask to be sure it will provide the necessary protection.
- All local regulations regarding protection against hazardous vapors must be observed.
- Wear protective eyewear.
- Protective clothing, gloves and possibly skin protection cream are necessary for the protection of the skin. Observe the regulations of the manufacturer concerning coating materials, solvents and cleaning agents in preparation, processing and cleaning units.



HAZARD: GENERAL

This product can cause severe injury or property damage.

PREVENTION:

- Follow all appropriate local, state, and national codes governing ventilation, fire prevention, and operation.
- Pulling the trigger causes a recoil force to the hand that is holding the spray gun. The recoil force of the spray gun is particularly powerful when the tip has been removed and a high pressure has been set on the airless pump. When cleaning without a spray tip, set the pressure control knob to the lowest pressure.
- Use only manufacturer authorized parts. User assumes all risks and liabilities when using parts that do not meet the minimum specifications and safety devices of the pump manufacturer.
- ALWAYS follow the material manufacturer's instructions for safe handling of paint and solvents.
- Clean up all material and solvent spills immediately to prevent slip hazard.
- Wear ear protection. This unit can produce noise levels above 85 dB(A).
- Never leave this equipment unattended. Keep away from children or anyone not familiar with the operation of airless equipment.
- Do not spray on windy days.
- The device and all related liquids (i.e. hydraulic oil) must be disposed of in an environmentally friendly way.

1.2 Electric Safety

Electric models must be earthed. In the event of an electrical short circuit, earthing reduces the risk of electric shock by providing an escape wire for the electric current. This product is equipped with a cord having an earthing wire with an appropriate earthing plug. Connection to the mains only through a special feed point, e.g. through an error protection installation with INF < 30 mA.



DANGER — Work or repairs at the electrical equipment may only be carried out by a skilled electrician. No liability is assumed for incorrect installation. Switch the unit off. Before all repair work, unplug the power plug from the outlet.

Danger of short-circuits caused by water ingressing into the electrical equipment. Never spray down the unit with high-pressure or high-pressure steam cleaners.

Work or repairs at the electrical equipment:

These may only be carried out by a skilled electrician. No liability is assumed for incorrect installation.

1.3 Electrostatic charging (formation of sparks or flames)



Electrostatic charging of the unit may occur during spraying due to the flow speed of the coating material. These can cause sparks and flames upon discharge. The unit must therefore always be earthed via the electrical system. The unit must be connected to an appropriately-grounded safety outlet.

An electrostatic charging of spray guns and the high-pressure hose is discharged through the high-pressure hose. For this reason the electric resistance between the connections of the high-pressure hose must be equal to or lower than 1 MΩ.

2. General view of application

2.1 Application

The unit performance is conceived so that its use is possible on building sites for small- to middle-area dispersion work.

Examples of objects of spraying

The sprayer is able for all common varnishing jobs like doors, door frames, balustrades, furniture, woodencladding, fences, radiators (heating) and steel parts.

2.2 Coating materials

Processible coating materials



Pay attention to the Airless quality of the coating materials to be processed.

Dilutable lacquers and paints or those containing solvents, two-component coating materials, dispersions, latex paints, release agents, oils, undercoats, primers, and fillers.

No other materials should be used for spraying without TITAN's approval.

Filtering

Despite suction filter and insertion filter in the spray gun, filtering of the coating material is generally advisable.

Stir coating material before commencement of work.



Attention: Make sure, when stirring up with motor-driven agitators that no air bubbles are stirred in. Air bubbles disturb when spraying and can, in fact, lead to interruption of operation.

Viscosity

With this unit it is possible to process highly viscous coating materials of up to around 20.000 MPa-s.

If highly viscous coating materials cannot be taken in by suction, they must be diluted in accordance with the manufacturer's instructions.

Two-component coating material

The appropriate processing time must be adhered to exactly. Within this time rinse through and clean the unit meticulously with the appropriate cleaning materials.

Coating materials with sharp-edged additional materials

These have a strong wear and tear effect on valves, high-pressure hose, spray gun and tip. The durability of these parts can be reduced appreciably through this.

3. Description of unit

3.1 Airless process

The main areas of application are thick layers of highly viscous coating material for large areas and a high consumption of material. A piston pump takes in the coating material by suction and conveys it to the tip. Pressed through the tip at a pressure of up to a maximum of 207 bar (20.7 MPa), the coating material is atomised. This high pressure has the effect of micro fine atomisation of the coating material.

As no air is used in this process, it is described as an AIRLESS process.

This method of spraying has the advantages of finest atomisation, cloudless operation and a smooth, bubble-free surface. As well as these, the advantages of the speed of work and convenience must be mentioned.

3.2 Functioning of the unit

In the following there is a short description of the technical construction for better understanding of the function.

Titan Performance Series 460e units are electrically driven high-pressure spraying units.

A gear unit transfers the driving force to a crankshaft. The crankshaft moves the pistons of the material feed pump up and down.

The inlet valve is opened automatically by the upwards movement of the piston. The outlet valve is opened when the piston moves downward.

The coating material flows under high pressure through the high-pressure hose to the spray gun. When the coating material exits from the tip it atomizes.

The pressure control knob controls the volume and the operating pressure of the coating material.



The Titan Performance Series 460e is available in different configurations. All information given in this manual applies to all configurations unless otherwise specified.

3.3 Legend for explanatory diagram Performance Series 460e

- | | |
|----------------------|--|
| 1 Spray gun | 9 Relief valve |
| 2 High-pressure hose | Lever position vertical – PRIME (↻ circulation) |
| 3 Return hose | Lever position horizontal – SPRAY (→) |
| 4 Suction hose | 10 Pressure control knob |
| 5 Frame | 11 Oil cup for Piston Lube (Piston Lube prevents increased wear of the packings) |
| 6 Drip cup | 12 Pressure gauge (if equipped) |
| 7 Power cord | 13 Pusher stem (if equipped) |
| 8 ON/OFF switch | |

3.4 Explanatory diagram Performance Series 460e

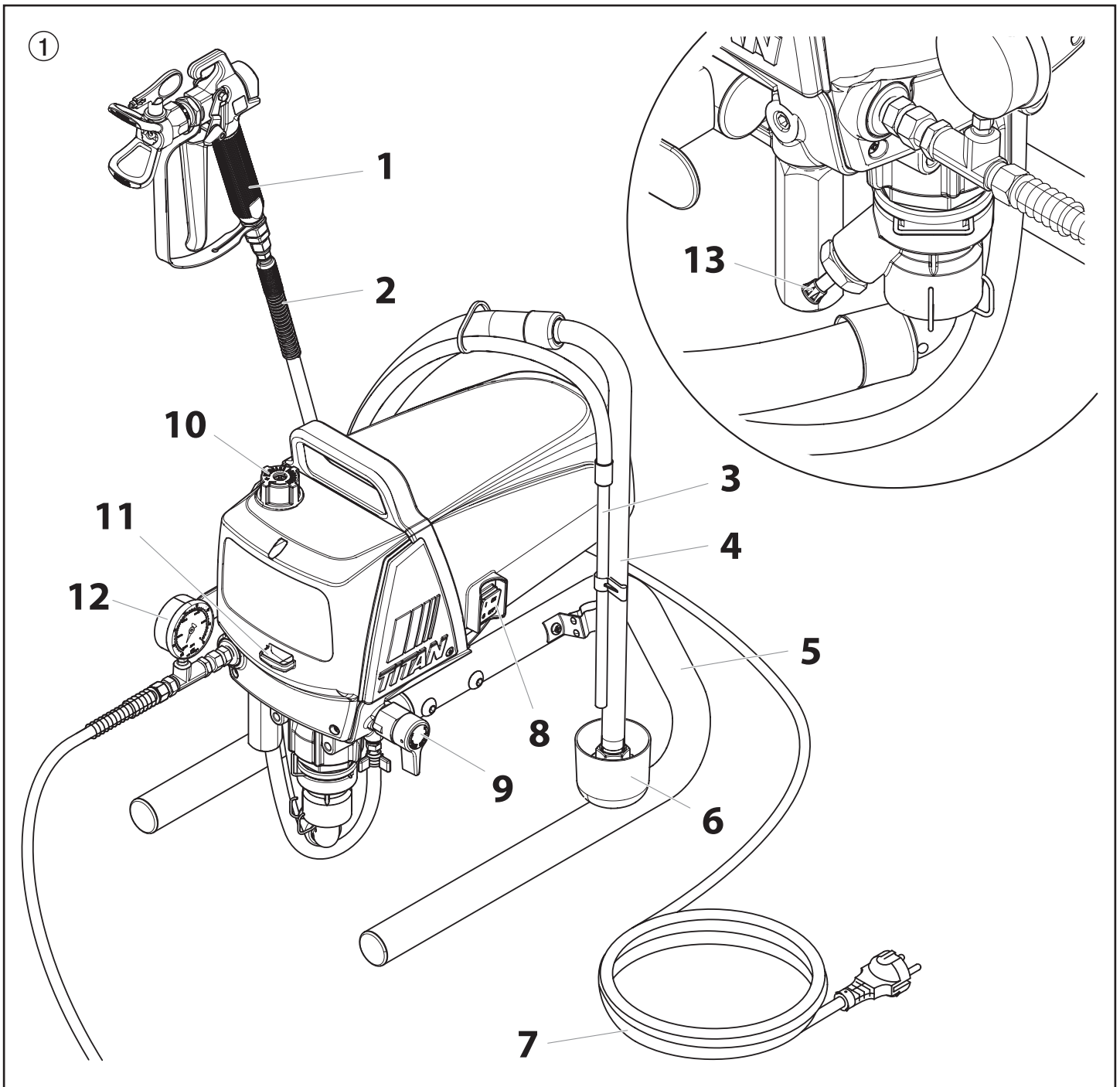

3.5 Technical data

Voltage	
	220~240 VAC, 50/60 Hz or 100~120 VAC, 50/60 Hz
Max. current consumption	
220~240 VAC	5.5 A
100~120 VAC	12 A
Power Cord	
	See page 68
Acceptance capacity	
	1000 Watt
Max. operating pressure	
	207 bar (20.7 MPa)
Volume flow at 12 MPa (120 bar) with water	
	1.62 l/min
Max tip size	
	0.021 inch – 0.53 mm
Max. temperature of the coating material	
	43°C
Max viscosity	
	20.000 MPa·s
Weight	
	13.6 kg
Special high-pressure hose	
	6,35 mm, 15 m - 1/4" - 18 NPSM
Dimensions (L X W X H)	
	441 x 324 x 415 mm
Vibration	
	Spray gun does not exceed 2.5m/s ²
Max sound pressure level	
	80 dB*

* Place of measuring: 1 m in distance from the unit and 1.6 m above the floor, 12 MPa (120 bar) operating pressure, reverberant floor.

3.6 Transportation in vehicle

Secure the unit with a suitable fastening.

4. Starting operation

4.1 High-pressure hose, spray gun and separating oil

1. If equipped, screw the pressure gauge (1) to the coating material outlet (Fig. 2, Item 2).
2. Screw the high-pressure hose (3) to the coating material outlet (Fig. 2, Item 4).
3. Screw the spray gun (5) with the selected tip onto the high-pressure hose.
4. Tighten the union nuts at the high-pressure hoses firmly so that coating material does not leak.

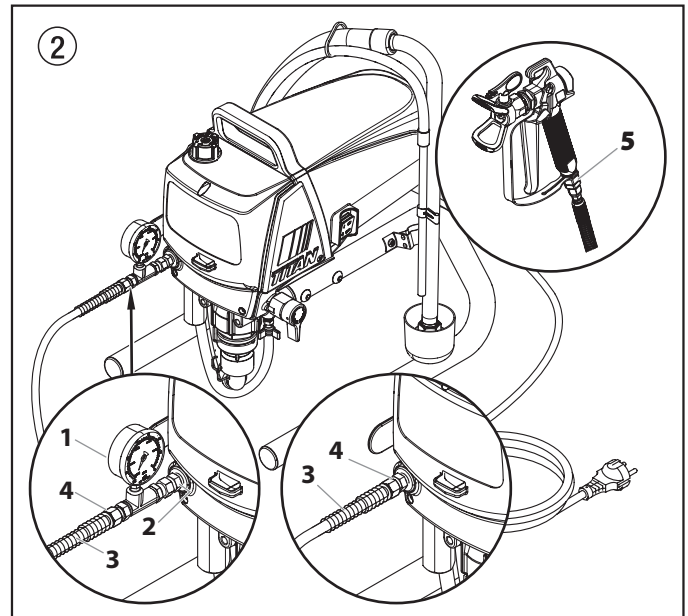

5. Fill the oil cup with Piston Lube (Fig. 3). Do not use too much Piston Lube, i.e. ensure that no Piston Lube drips into the coating material container.



Attention

Piston Lube prevents increased wear and tear to the packings.

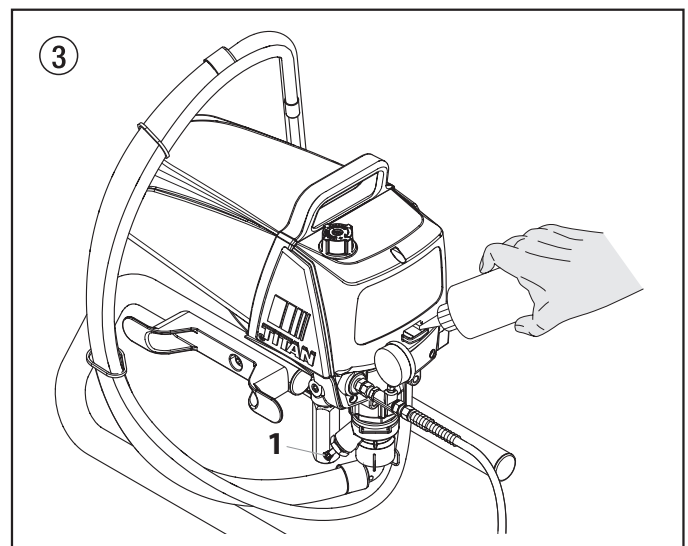

6. If equipped, fully depress the pusher stem (Fig. 3, item 1) to make sure the inlet ball is free.

4.2 Connection to the mains network



The unit must be connected to an appropriately-grounded safety outlet.

Attention

Before connecting the unit to the mains supply, ensure that the line voltage matches that specified on the unit's rating plate.

The connection must be equipped with a residual current protective device with INF \leq 30 mA.



Titan's accessories program also includes a mobile operator protection device for the electronic supply, which can also be used with other electronic equipment.

4.3 Cleaning preserving agent when starting-up of operation initially

1. Immerse the suction tube (Fig. 4, Item 2) return hose (1) into a container with a suitable cleaning agent.
2. Turn the pressure control knob counterclockwise (3) to minimum pressure.
3. Open the relief valve (4), valve position PRIME (↻ circulation).
4. Switch the unit (5) ON.
5. Wait until the cleaning agent exudes from the return hose.
6. Close the relief valve, valve position SPRAY (↗ spray).
7. Pull the trigger of the spray gun.
8. Spray the cleaning agent from the unit into an open collecting container.

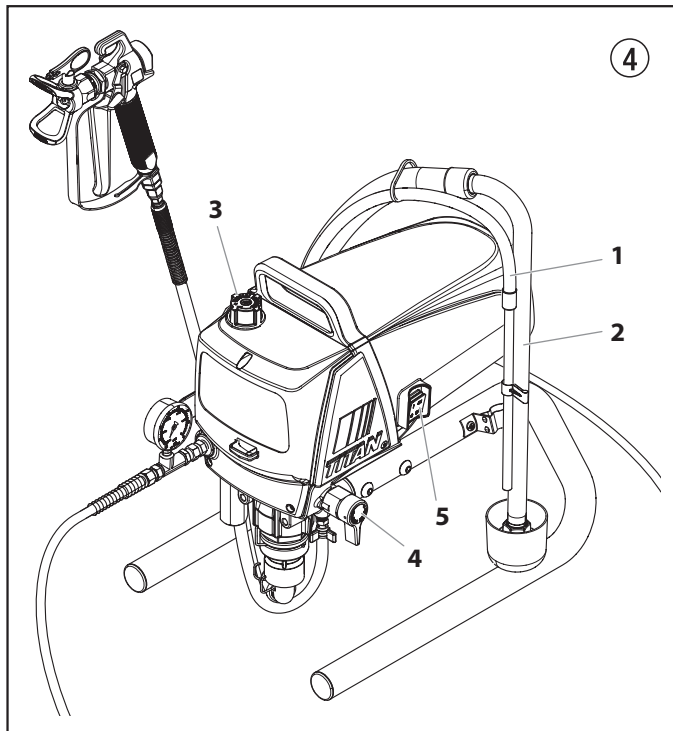

4.4 Taking the unit into operation with coating material

1. Immerse the suction tube (Fig. 4, Item 2) and return hose (1) into the coating material container.
2. Turn the pressure control knob counterclockwise (3) to minimum pressure.
3. Open the relief valve (4), valve position PRIME (↻ circulation).
4. Switch the unit (5) ON.
5. Wait until the coating material exudes from the return hose.
6. Close the relief valve, valve position SPRAY (↗ spray).
7. Trigger the spray gun several times and spray into a collecting container until the coating material exits the spray gun without interruption.
8. Increase the pressure by slowly turning up the pressure control knob.

Check the spray pattern and increase the pressure until the atomization is correct.

Always turn the pressure control knob to the lowest setting with good atomization.

9. The unit is ready to spray.

5. Spraying technique



Injection hazard. Do not spray without the tip guard in place. NEVER trigger the gun unless the tip is completely turned to either the spray or the unclog position. ALWAYS engage the gun trigger lock before removing, replacing or cleaning tip.

The key to a good paint job is an even coating over the entire surface. Keep your arm moving at a constant speed and keep the spray gun at a constant distance from the surface. The best spraying distance is 25 to 30 cm between the spray tip and the surface.

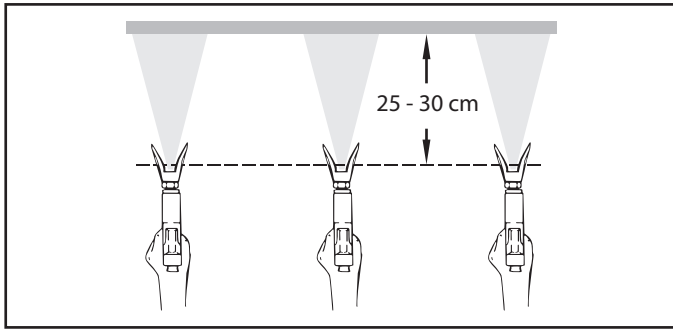

Keep the spray gun at right angles to the surface. This means moving your entire arm back and forth rather than just flexing your wrist.

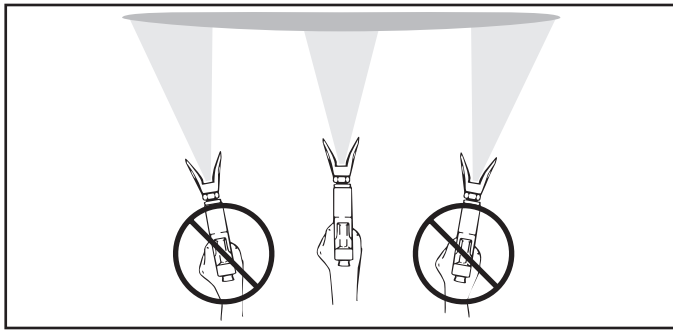

Keep the spray gun perpendicular to the surface, otherwise one end of the pattern will be thicker than the other.

Trigger gun after starting the stroke. Release the trigger before ending the stroke. The spray gun should be moving when the trigger is pulled and released. Overlap each stroke by about 30%. This will ensure an even coating.

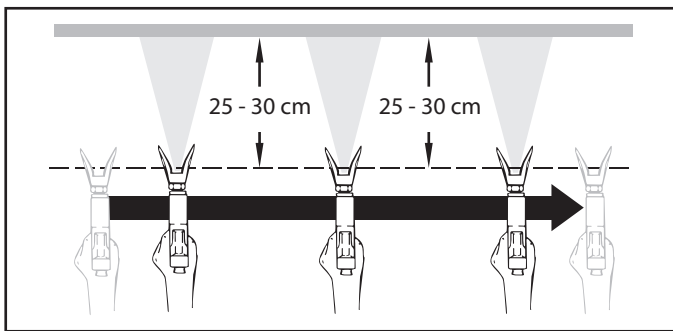

If very sharp edges result or if there are streaks in the spray jet – increase the operating pressure or dilute the coating material.

6. Handling the high-pressure hose

The unit is equipped with a high-pressure hose specially suited for piston pumps.



Danger of injury through leaking high-pressure hose. Replace any damaged high-pressure hose immediately.

Never repair defective high-pressure hoses yourself!

The high-pressure hose is to be handled with care. Avoid sharp bends and folds: the smallest bending radius is about 20 cm.

Do not drive over the high-pressure hose. Protect against sharp objects and edges.

Never pull on the high-pressure hose to move the device.

Make sure that the high-pressure hose cannot twist. This can be avoided by using a Titan spray gun with a swivel joint and a hose system.



When using the high-pressure hose while working on scaffolding, it is best to always guide the hose along the outside of the scaffolding.



The risk of damage rises with the age of the high-pressure hose. Titan recommends replacing high-pressure hoses after 6 years.



Use only Titan original-high-pressure hoses in order to ensure functionality, safety and durability.

7. Interruption of work

1. Open the relief valve, valve position PRIME (↻ circulation).
2. Switch the unit OFF.
3. Turn the pressure control knob counterclockwise to minimum pressure.
4. Pull the trigger of the spray gun in order to release the pressure from the high-pressure hose and spray gun.
5. Secure the spray gun, refer to the operating manual of the spray gun.
6. If a standard tip is to be cleaned, see Page 18, Section 12.2. If a non-standard tip is installed, proceed according to the relevant operating manual.
7. Depending on the model, leave the suction tube or the suction hose and return hose immersed in the coating material or swivel or immerse it into a corresponding cleaning agent.



If fast-drying or two-component coating material is used, ensure that the unit is rinsed with a suitable cleaning agent within the processing time.

8. Cleaning the unit (shutting down)

A clean state is the best method of ensuring operation without problems. After you have finished spraying, clean the unit. Under no circumstances may any remaining coating material dry and harden in the unit.

The cleaning agent used for cleaning (only with an ignition point above 21 °C) must be suitable for the coating material used.

- **Secure the spray gun**, refer to the operating manual of the spray gun.

Clean and remove tip.

For a standard tip, refer to Page 18, Section 12.2.

If a non-standard tip is installed, proceed according to the relevant operating manual.

1. Remove suction hose from the coating material.
2. Close the relief valve, valve position SPRAY (→ spray).
3. Switch the unit ON.



Attention

The container must be earthed in case of coating materials which contain solvents.



Caution! Do not pump or spray into a container with a small opening (bunghole)! Refer to the safety regulations.

4. Pull the trigger of the spray gun in order to pump the remaining coating material from the suction hose, high-pressure hose and the spray gun into an open container.
5. Immerse suction hose with return hose into a container with a suitable cleaning agent.
6. Turn the pressure control knob counterclockwise to minimum pressure.
7. Open the relief valve, valve position PRIME (↻ circulation).
8. Pump a suitable cleaning agent in the circuit for a few minutes.
9. Close the relief valve, valve position SPRAY (→ spray).
10. Pull the trigger of the spray gun.
11. Pump the remaining cleaning agent into an open container until the unit is empty.
12. Switch the unit OFF.

8.1 Cleaning unit from outside



First of all pull out mains plug from socket.



Attention

Danger of short circuit through penetrating water! Never spray down the unit with high-pressure or high-pressure steam cleaners.



Attention

Do not put the high-pressure hose into solvents. Use only a wet cloth to wipe down the outside of the hose.

Wipe down unit externally with a cloth which has been immersed in a suitable cleaning agent.

8.2 Suction filter



A clean suction filter always guarantees maximum feed quantity, constant spraying pressure and problem-free functioning of the unit.

1. Screw off the filter (Fig. 5) from suction pipe.
2. Clean or replace the filter.

Carry out cleaning with a hard brush and an appropriate cleaning agent.

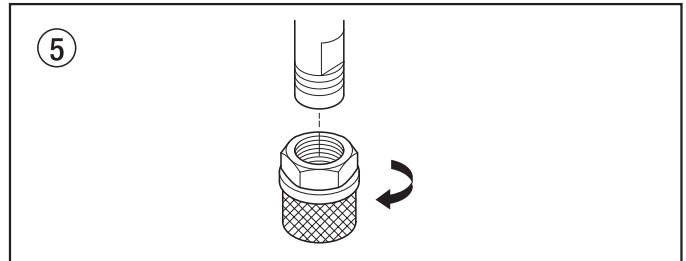

8.3 Cleaning the high-pressure filter



Clean the filter cartridge regularly. A soiled or clogged high-pressure filter can cause a poor spray pattern or a clogged tip.

1. Turn the pressure control knob counterclockwise to minimum pressure.
2. Open the relief valve, valve position PRIME (↻ circulation).
3. Switch the unit OFF.



Unplug the power plug from the outlet.

4. Unscrew the filter housing (Fig. 6, Item 1) with a strap wrench.
5. Turning clockwise, unscrew the filter (2) from the pump manifold (3).
6. Clean all the parts with the corresponding cleaning agent. If necessary, replace the filter cartridge.
7. Check the O-ring (4), replace it if necessary.
8. Turning counterclockwise, screw the new or cleaned filter into the pump manifold.
9. Screw in filter housing (1) and tighten it as far as possible with the strap wrench.

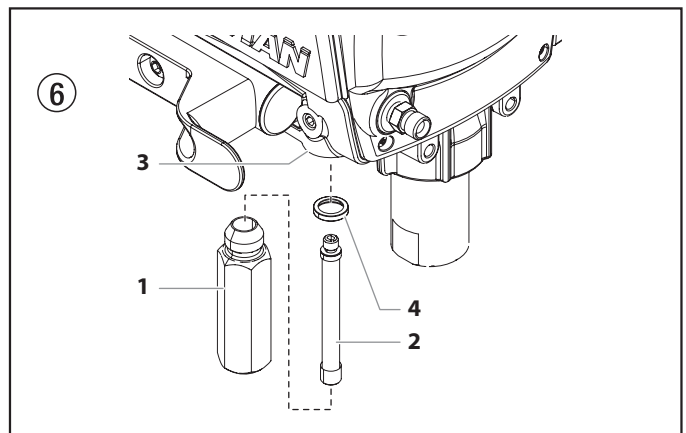

8.3 Cleaning Airless spray gun

1. Rinse Airless spray gun with an appropriate cleaning agent.
2. Clean tip thoroughly with appropriate cleaning agent so that no coating material residue remains.
3. Thoroughly clean the outside of the Airless spray gun.

Intake filter in Airless spray gun (Fig. 7)

Disassembly

1. Pull protective guard (1) forward vigorously.
2. Screw grip (2) out of the gun housing. Remove intake filter (3).
3. Intake filter congested or defective – replace.

Assembly

1. Place intake filter (3) with the long cone into the gun housing.
2. Screw in grip (2) into the gun housing and tighten.
3. Slot in protective guard (1).

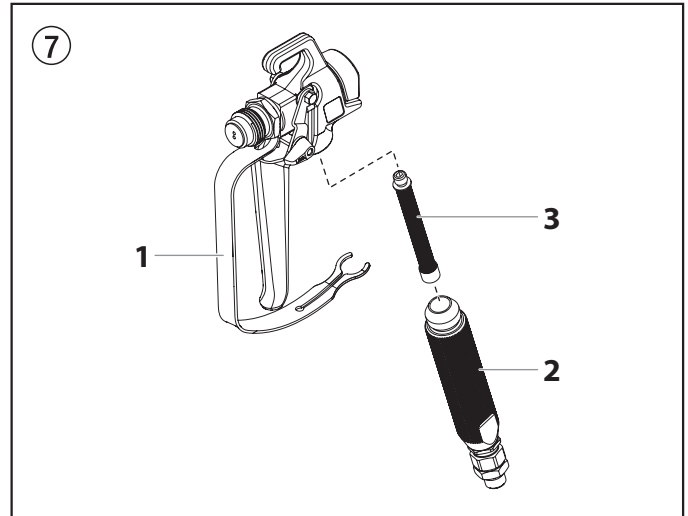

9. Remedy in case of faults

Type of malfunction	Possible cause	Measures for eliminating the malfunction
A. Unit does not start	<ol style="list-style-type: none"> 1. No voltage applied. 2. Pressure setting too low. 3. ON/OFF switch defective. 	<ol style="list-style-type: none"> 1. Check voltage supply. 2. Turn up pressure control knob. 3. Replace.
B. Unit does not draw in material	<ol style="list-style-type: none"> 1. Relief valve is set to SPRAY (→ spray). 2. Filter projects over the fluid level and sucks air. 3. Filter clogged. 4. Suction hose/suction tube is loose, i.e. the unit is sucking in outside air. 	<ol style="list-style-type: none"> 1. Set relief valve to PRIME (↻ circulation). 2. Refill the coating material. 3. Clean or replace the filter. 4. Clean connecting points. Replace O-rings if necessary. Secure suction hose with retaining clip.
C. Unit draws in material, but the pressure does not build up	<ol style="list-style-type: none"> 1. Tip heavily worn. 2. Tip too large. 3. Pressure setting too low. 4. Filter clogged. 5. Coating material flows through the return hose when the relief valve is in the SPRAY (→ spray) position. 6. Packings sticky or worn. 7. Valve balls worn. 8. Valve seats worn. 	<ol style="list-style-type: none"> 1. Replace 2. Replace tip. 3. Turn pressure control knob clockwise to increase. 4. Clean or replace the filter. 5. Remove and clean or replace relief valve. 6. Remove and clean or replace packings. 7. Remove and replace valve balls. 8. Remove and replace valve seats.
D. Coating material exits at the top of the fluid section	<ol style="list-style-type: none"> 1. Upper packing is worn. 2. Piston is worn. 	<ol style="list-style-type: none"> 1. Remove and replace packing. 2. Remove and replace piston.
E. Increased pulsation at the spray gun	<ol style="list-style-type: none"> 1. Incorrect high-pressure hose type. 2. Tip worn or too large. 3. Pressure too high. 	<ol style="list-style-type: none"> 1. Only use TITAN original-high-pressure hoses in order to ensure functionality, safety and durability. 2. Replace tip. 3. Turn pressure control knob to a lower number.
F. Poor spray pattern	<ol style="list-style-type: none"> 1. Tip is too large for the coating material which is to be sprayed. 2. Pressure setting incorrect. 3. Volume too low. 4. Coating material viscosity too high. 	<ol style="list-style-type: none"> 1. Replace tip. 2. Turn pressure control knob until a satisfactory spraying pattern is achieved. 3. Clean or replace all filters. 4. Thin out according to the manufacturer's instructions.
G. Unit loses power	<ol style="list-style-type: none"> 1. Pressure setting too low. 	<ol style="list-style-type: none"> 1. Turn pressure control knob clockwise to increase.
H. Pump over-pressurizes and will not shut off.	<ol style="list-style-type: none"> 1. Pressure switch defective. 2. Transducer defective. 	<ol style="list-style-type: none"> 1. Take unit to a Titan authorized service center. 2. Take unit to a Titan authorized service center.

10. Servicing

10.1 General servicing

Servicing of the unit should be carried out once annually by the TITAN service.

1. Check high-pressure hoses, device connecting line and plug for damage.
2. Check the inlet valve, outlet valve and filter for wear.

10.2 High-pressure hose

Inspect the high-pressure hose visually for any notches or bulges, in particular at the transition in the fittings. It must be possible to turn the union nuts freely.



The risk of damage rises with the age of the high-pressure hose. Titan recommends replacing high-pressure hoses after 6 years.

11. Repairs at the unit



Switch the unit OFF.

Before all repair work: Unplug the power plug from the outlet.

11.1 Relief valve



Attention

The valve housing (4) should not be repaired. If worn, it should always be replaced with a new one.

1. Use a drift punch of 2 mm to remove the grooved pin (Fig. 8, Item 1) from the relief valve handle (2).
2. Remove the relief valve handle (2) and cam base (3).
3. Using a wrench, remove the valve housing (4) from the pump manifold (6).
4. Ensure that the seal (5) is seated correctly, then screw the new valve housing (4) completely into the pump manifold (6). Tighten securely with a wrench.
5. Align the cam base (3) with the hole in the pump manifold (6). Lubricate the cam base with grease and slide on the cam base.
6. Bring the hole in the valve shaft (7) and in the relief valve handle (2) into alignment.
7. Insert the grooved pin (1) to secure the relief valve handle in position.

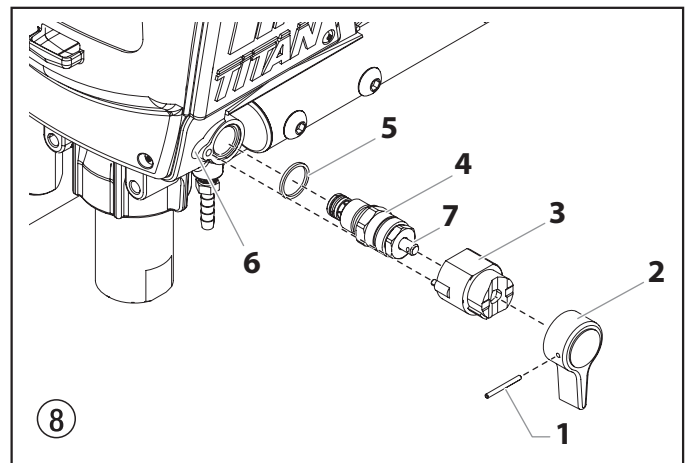

11.2 Inlet and outlet valve

1. Remove the screw that secures the pressure control knob. Remove the knob.
Remove the five screws in the front cover and then remove the front cover.
2. Switch the unit ON and then OFF so that the piston rod is positioned in the lower stroke position.



Danger of crushing - do not reach with the fingers or tool between the moving parts.

3. Unplug the power plug from the outlet.
4. Remove the retaining clip from the connecting bend at the suction hose and pull off the suction hose.
5. Screw off the return hose.
6. Swivel the unit 90° to the rear in order to work more easily on the material feed pump.
7. If equipped - Remove the pusher stem clip and slide the pusher housing (7) from the inlet valve housing (1).
8. Unscrew the inlet valve housing (Fig. 10, Item 1) from the pump manifold (2).
9. Remove the lower ball guide (6), lower seal (5), inlet valve ball (4), inlet valve seat (3) and O-ring (8).
10. Clean all the parts with the corresponding cleaning agent. Check the inlet valve housing (1), inlet valve seat (3) and inlet valve ball (4) for wear and replace the parts if necessary.

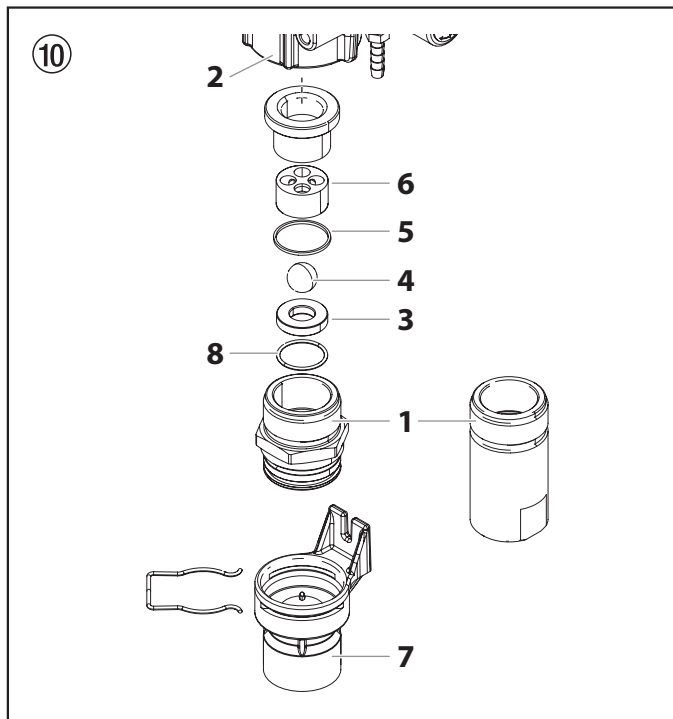

11. Unscrew outlet valve housing (Fig. 11, Item 9) from the piston (10) with adjusting wrench.
12. Remove the upper ball guide (14), crush washer (13), outlet valve ball (12), and outlet valve seat (11).
13. Clean all the parts with the corresponding cleaning agent. Check outlet valve housing (9), outlet valve seat (11), outlet valve ball (12) and upper ball guide (14) for wear and replace parts if necessary.
14. Carry out installation in the reverse order. Make sure the outlet valve retainer (9) is reinstalled with the non-threaded "lip" facing up into the piston. Lubricate O-ring (Fig. 10, Item 8) with machine grease and ensure proper seating in the inlet valve housing (Fig. 10, Item 1).

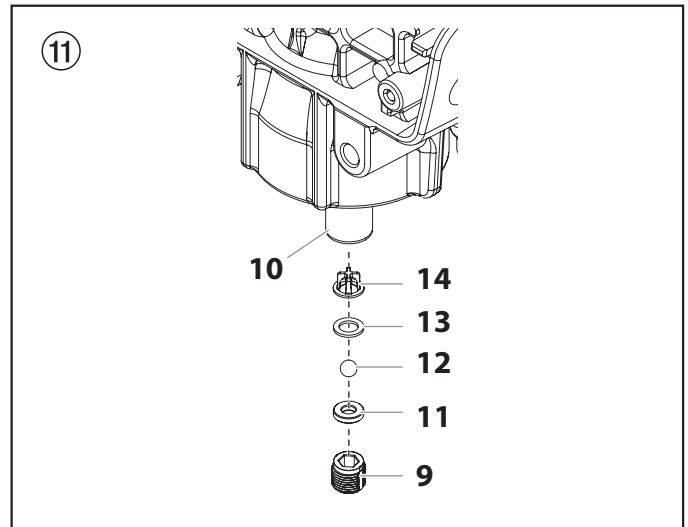

11.3 Packings

Disassembly (Fig. 12)

1. Remove inlet valve housing in accordance with the steps in Chapter 11.2. It is not necessary to remove the outlet valve.
2. Remove the yoke screw (14) and washer (15) that secures the dowel pin (16). The dowel pin connects the yoke (17) to the piston (18).
3. Using a pliers, pull the dowel pin (16) out.
4. Rotate the pump shaft so the piston is in the top dead center position. Press the yoke (17) against the top bushing (19) with a screwdriver, for example. This is required to disassemble all the parts.
5. Remove the piston assembly (18) by pushing down on the piston near the yoke (17).
6. Unscrew and remove the upper bushing (19) using an adjustable wrench.
7. Remove the worn seals using a flat head screwdriver or punch. Remove the upper packing (20) from the top and the lower packing (21) from the bottom by pressing against the side of the seal and popping it out. Be sure not to scratch the housing where the seals are located.
8. Clean the area where the new packings are to be installed.

Assembly (Fig. 12)

1. Slide the upper packing (20) off the grey sizing/insertion tool (towards the tip) and install into the top of the pump housing with the raised lip (23) facing down. Save the upper packing sizing/insertion tool for use in step 6.
2. Place the upper bushing (19) into the top of the housing and tighten with an adjustable wrench (torque to 300-360 in-lbs). This will drive the upper packing (20) into the correct position.
3. Tilt the pump backwards so that it is laying on its back. Remove the plastic wrap from the lower packing and red pre-form tool.



Attention

Cut the plastic wrap with a scissors. Do not cut plastic wrap with a utility knife as damage can occur to the O-rings.

4. Slide the lower packing (21) off the pre-form tool (towards the top). Insert the lower packing partially into the bottom of the pump block so that the beveled edge (24) of the packing faces up.

5. Thread the inlet valve housing (22) back into the bottom of the pump housing by hand to drive the lower packing into place. Once tightened as far as it will go, unthread and remove again.
6. Place the grey insertion tool over the top of the piston assembly (18). Coat the piston guide tool and the piston rod with grease before inserting them into the pump housing.
7. Insert the piston assembly into the bottom of the pump block and push upward until the hole in the piston is aligned with the hole in the yoke (17). Discard insertion tool.



Attention

Make sure the piston is inserted precisely through the middle of the upper and lower packing. Coming in at an angle will bump the piston into the sides of the packings and cause damage.

8. Apply any type of household grease to the piston and yoke area to prolong life. Apply to the holes in the yoke where the dowel (16) is inserted.
9. Install the dowel pin (16) to connect the yoke (17) to the piston (18). The piston may have to be moved up or down to do this.
10. Install the yoke screw (14) and washer (15) to secure the dowel pin.
11. Turn pump right side up and apply a few drops of Piston Lube or light household oil between the top nut (19) and piston (18). This will prolong the seal life.
12. Reinstall the inlet valve assembly (22). Tighten by hand until it cannot be tightened further, and then tighten another 1/2 turn with a wrench. This will automatically secure the lower packing (21) into place.
13. If equipped, replace pusher assembly (26) onto inlet valve assembly.
14. Install front cover and three screws.
15. Reinstall the pressure control knob. Secure with the screw.
16. Reinstall the suction tube and return tube.



If the knob bottom (25) has been removed from the pressure switch assembly, it must be re-calibrated prior to reinstallation. Follow the "Resetting the Pressure Switch Timing" instructions.

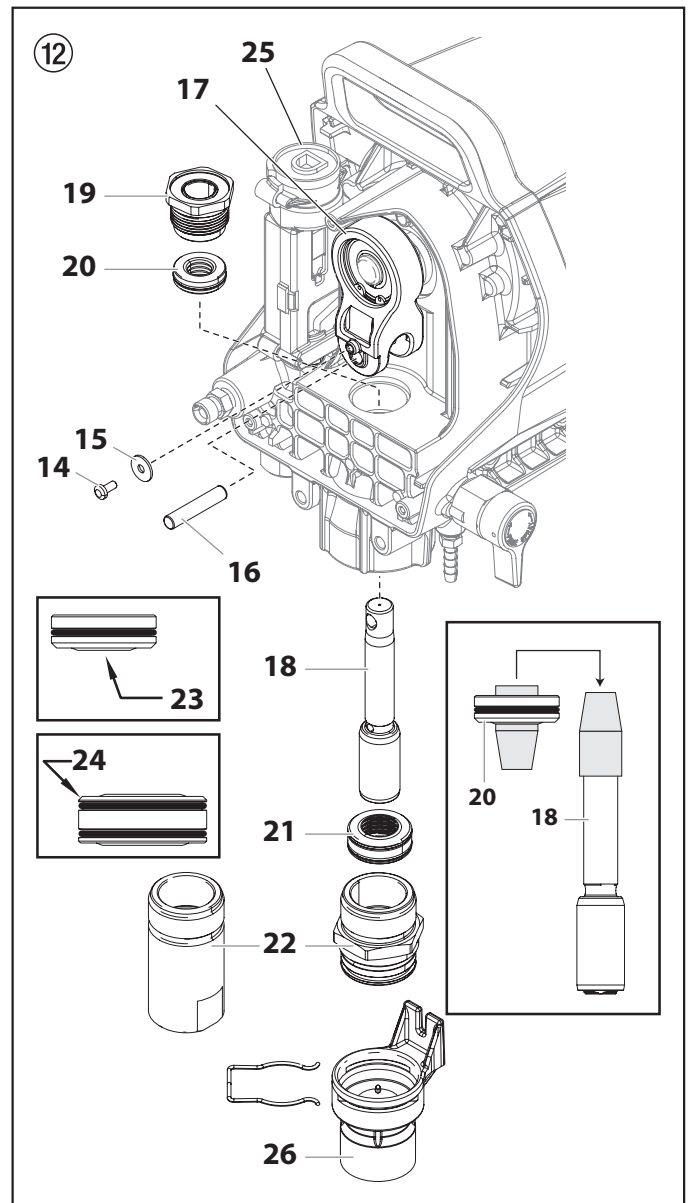

11.4 Replacing the Motor

i The following procedure must only be performed by a Titan Authorized Service Center.

1. Open the relief valve, valve position PRIME (↻ circulation). Switch the unit OFF. Unplug the power plug from the outlet.
2. Loosen and remove the four motor cover screws (1). Remove the motor cover (2).

i The ON / OFF switch (3) is housed inside the motor cover. In order to remove the motor cover completely, you must disconnect all of the wires at the rear of the switch. Note the position of the wires before disconnecting.

3. On the back of the motor (4), disconnect the two wires (black and red) coming from the circuit board (5). Remove the ground wire from the motor housing.
4. Slide the motor baffle (7) off the rear of the motor.
5. Loosen and remove the four motor mounting screws (8).
6. Pull the motor (4) out of the pump housing (9).
7. With the motor removed, inspect the gears in the pump housing (9) for damage or excessive wear. Replace the gears, if necessary.
8. Install the new motor (4) into the pump housing (9).
9. Secure the motor with the four motor mounting screws (8).
10. Reconnect the wires (Refer to the Connection Diagram, section 11.9).
11. Slide the motor baffle (7) onto the rear of the motor. The arrows on the baffle should be pointed up.
12. Slide the motor cover (2) over the motor. Secure the motor cover with the four motor cover screws (1).

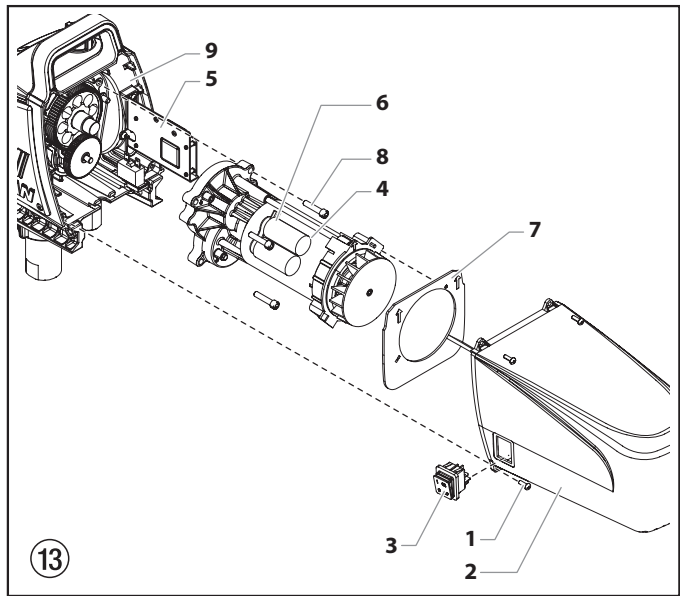

11.5 Replacing the Gears

i The following procedure must only be performed by a Titan Authorized Service Center.

1. Open the relief valve, valve position PRIME (↻ circulation). Switch the unit OFF. Unplug the power plug from the outlet.
2. Loosen and remove the four motor cover screws (1). Remove the motor cover (2).

i The ON / OFF switch (3) is housed inside the motor cover. In order to remove the motor cover completely, you must disconnect all of the wires at the rear of the switch. Note the position of the wires before disconnecting.

3. On the back of the motor (4), disconnect the two wires (black and red) coming from the circuit board (5). Remove the ground wire from the motor housing.
4. Slide the motor baffle (7) off the rear of the motor.
5. Loosen and remove the four motor mounting screws (8).
6. Pull the motor (4) out of the pump housing (9).
7. Inspect the armature gear (10) on the end of the motor for damage or excessive wear. If this gear is completely worn out, replace the entire motor.
8. Remove and inspect the 2nd stage gear (11) for damage or excessive wear. Replace if necessary.
9. If the armature gear (10) or 2nd stage gear (11) are damaged, the pump housing (9) must be cleaned of any debris caused by damaged gears.
10. Reassemble the pump by reversing the above steps.

i Refill the gear box in the pump housing with five ounces of Lubriplate (P/N 314-171).

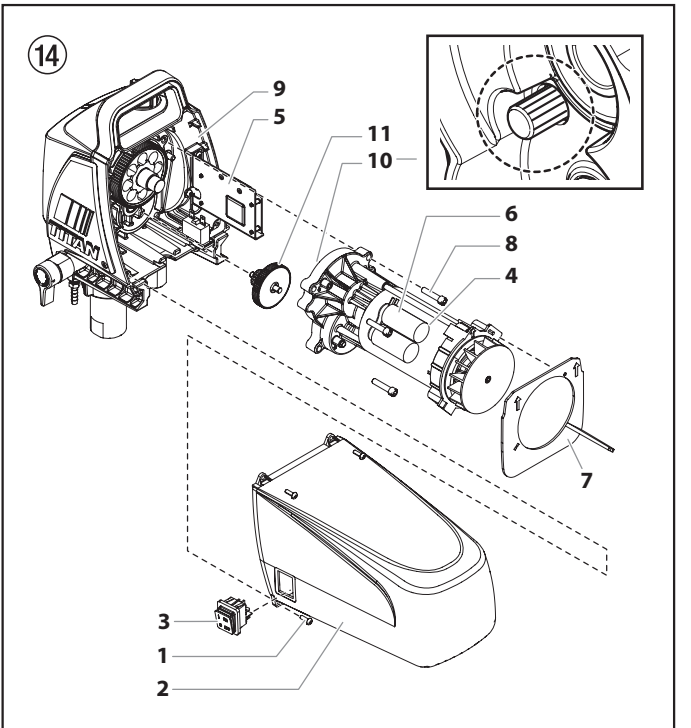

11.6 Replacing the Pressure Switch / Transducer

i The following procedure must only be performed by a Titan Authorized Service Center.

i If the sprayer loses all pressure adjustment, or there is paint leakage from the front of the sprayer, the pressure switch and/or transducer may need to be replaced.

1. Open the relief valve, valve position PRIME (☉ circulation). Switch the unit OFF. Unplug the power plug from the outlet.
2. Remove the screw (1) that secures the pressure control knob (2) to the bottom of the pressure control knob (3). Remove the knob (2).
3. Loosen and remove the three front cover screws (4). Remove the front cover (5).
4. Remove the screw (7) from the side of the pressure switch. Remove the bottom of the pressure control knob (3) from the top of the pressure switch.
5. Remove the pressure switch assembly (6) from the top of the transducer (8).
6. Unplug the pressure switch (6) from the wire connector (10).



Attention

Do not attempt to pull wires from the inside of the pressure switch assembly. If the pressure switch wire connector (10) is not exposed from through the opening in the pump housing, pull gently on the wires until the connector is shown through the opening.

7. Check pressure switch continuity at the connector. If the switch is bad replace with a new pressure switch assembly.
8. Inspect the transducer (8) for the presence of paint. If there is paint, replace the transducer. If there is no paint, skip to step 9, below.
 - a. Using a wrench on the hex head of the transducer, loosen and remove the transducer assembly.
 - b. Apply a generous amount of grease to the transducer O-ring (9). Reinstall the transducer assembly and torque to 70-75 in/lbs.
9. Reconnect the wires (Refer to the Connection Diagram, section 11.9).
10. Push pressure switch assembly (6) back onto the transducer until it bottoms out on the transducer hex head.
11. Replace the screw (7) into the side of the pressure switch.
12. See "Resetting the Pressure Switch Timing", section 11.7.

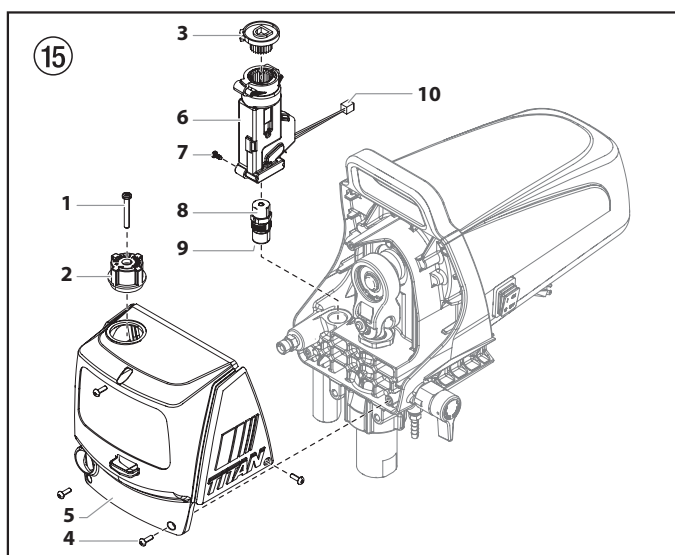

11.7 Resetting the Pressure Switch Timing

i The following procedure must only be performed by a Titan Authorized Service Center.

i The components of the pressure switch must be properly reassembled and adjusted in order for the pump to operate at the correct maximum pressure.

Perform this procedure using pressure gauge P/N 0521229.

1. Make sure the knob bottom (1) is installed in the pressure switch (2).
2. Viewing from the top, turn the knob bottom (1) counter-clockwise as far as the teeth inside the pressure switch will allow.

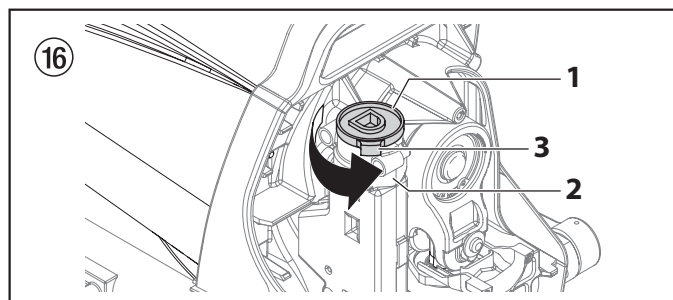

i If the stop (3) on the pressure switch prevents the knob bottom from continuing to turn, remove the knob bottom, re-orient it on the teeth and continue to turn it counterclockwise until it stops.

3. Re-orient the knob tab against the pressure switch tab stop.

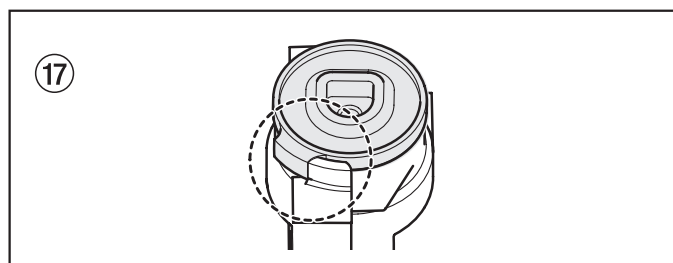

4. Replace the front cover and secure with the three screws.
5. Replace the pressure control knob into the knob bottom but do not secure with the screw. Turn the knob fully clockwise to maximum.
6. Connect the pressure gauge to the outlet fitting.
7. Connect a high-pressure hose and gun to the pressure gauge.
8. Using water as a media, follow the steps in section 4.4. It is not necessary to attach a spray tip to the gun. Leave the pressure set to maximum.
9. The sprayer should now be pressurized at maximum pressure. The pressure gauge should be reading between 193-207 bar.
10. If the pressure reading is below or above this reading, the set screw down inside the pressure switch will have to be adjusted. Adjust it per the guidelines below using a long hex wrench.
 - a. If the pressure reading is below 193 bar, turn the set screw counterclockwise until the pressure gauge reads between 193-207 bar.
 - b. If the pressure reading is above 207 bar, relieve pressure by turning the valve handle to PRIME (☉ circulation). While the sprayer is circulating, turn the set screw clockwise slightly and then turn the valve handle to SPRAY (☼ spray). Repeat this until the pressure reading decreases to a range of 193-207 bar.
11. When the pressure gauge reads between 193-207 bar, the pressure control knob is now set. Secure the pressure control knob with the pressure control knob screw.

11.8 Replacing the Circuit Board



The following procedure must only be performed by a Titan Authorized Service Center.

Perform this procedure using Circuit Board Kit.

1. Open the relief valve, valve position PRIME (☉ circulation). Switch the unit OFF. Unplug the power plug from the outlet.
2. Loosen and remove the four motor cover screws (1). Remove the motor cover (2).
3. Disconnect the red and black wires that connect the circuit board (3) to the motor assembly (4).
4. Disconnect the white wires that connect the circuit board to the pressure switch.



Attention

Do not attempt to pull wires from the inside of the pressure switch assembly. If the pressure switch wire connector is not exposed from through the opening in the pump housing, pull gently on the wires until the connector is shown through the opening.

5. Disconnect the black wire that connects the circuit board to the circuit breaker (6).
6. Disconnect the white wire that connects the circuit board to the power switch.
7. Loosen and remove the two circuit board screws (8). Remove the circuit board (3).
8. Install the new circuit board (3) and secure with the two circuit board screws (8).
9. Reconnect the wires that were disconnected in steps 3-6 (Refer to the Connection Diagram, section 11.9).
10. Slide the motor cover over the motor. Secure the motor cover with the four motor cover screws.

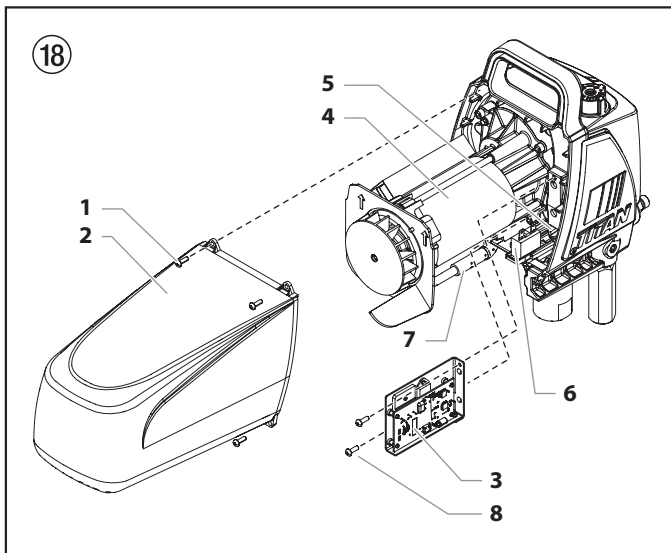

11.9 Performance Series 460e connection diagram

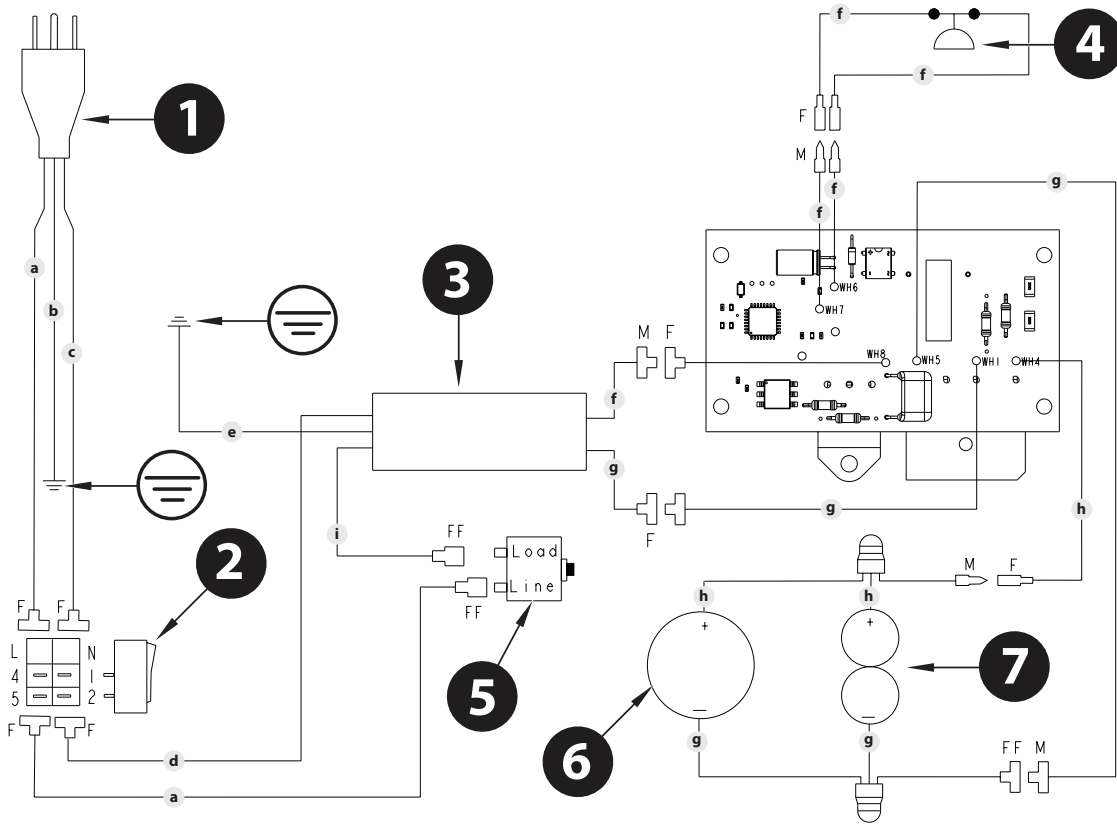

With EMI filter	
Pos.	Description
1	Power cord
2	Power switch
3*	EMI filter
4	Pressure switch
5	Circuit breaker
6	Motor
7	Capacitors

Pos.	Description
a	Black / brown
b	Green
c	White / blue
d	Blue
e	Green / yellow
f	White
g	Black
h	Red
i	Brown

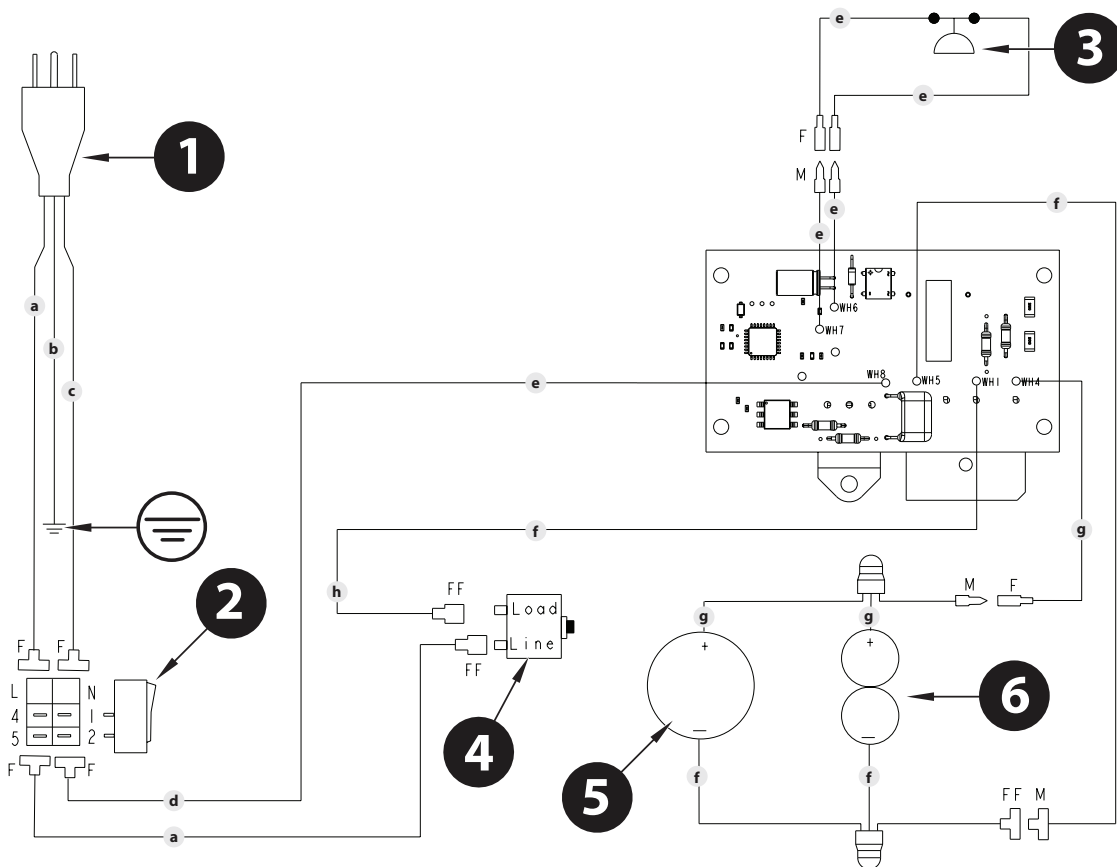

Without EMI filter	
Pos.	Description
1	Power cord
2	Power switch
3	Pressure switch
4	Circuit breaker
5	Motor
6	Capacitors

Pos.	Description
a	Black / brown
b	Green
c	White / blue
d	Blue
e	White
f	Black
g	Red
h	Brown

12.4 Airless tip table

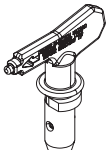

**Titan
SC6+ tip**
up to 270 bar
(27 MPa)

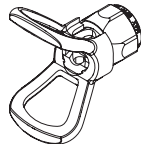

without tip
G thread (7/8 - 14 UN)
for Graco/Titan spray guns
Order no. 0289228



All of the tips in the table below are supplied together with the appropriate gun filter.

Application	Tip marking	Spray angle	Bore inch / mm	Spraying width mm 1)	Gun filter	Order no.
Water-thinnable and solvent-based paints and varnishes, oils, separating agents	107	10°	0.007 / 0.18	100	red	662-107
	207	20°	0.007 / 0.18	120	red	662-207
	307	30°	0.007 / 0.18	150	red	662-307
	407	40°	0.007 / 0.18	190	red	662-407
	109	10°	0.009 / 0.23	100	red	662-109
	209	20°	0.009 / 0.23	120	red	662-209
	309	30°	0.009 / 0.23	150	red	662-309
	409	40°	0.009 / 0.23	190	red	662-409
	509	50°	0.009 / 0.23	225	red	662-509
	609	60°	0.009 / 0.23	270	red	662-609
Synthetic-resin paints PVC paints	111	10°	0.011 / 0.28	100	red	662-111
	211	20°	0.011 / 0.28	120	red	662-211
	311	30°	0.011 / 0.28	150	red	662-311
	411	40°	0.011 / 0.28	190	red	662-411
	511	50°	0.011 / 0.28	225	red	662-511
	611	60°	0.011 / 0.28	270	red	662-611
Paints, primers Fillers	113	10°	0.013 / 0.33	100	red	662-113
	213	20°	0.013 / 0.33	120	red	662-213
	313	30°	0.013 / 0.33	150	red	662-313
	413	40°	0.013 / 0.33	190	red	662-413
	513	50°	0.013 / 0.33	225	red	662-513
	613	60°	0.013 / 0.33	270	red	662-613
Fillers Rust protection paints	115	10°	0.015 / 0.38	100	yellow	662-115
	215	20°	0.015 / 0.38	120	yellow	662-215
	315	30°	0.015 / 0.38	150	yellow	662-315
	415	40°	0.015 / 0.38	190	yellow	662-415
	515	50°	0.015 / 0.38	225	yellow	662-515
	615	60°	0.015 / 0.38	270	yellow	662-615
Rust protection paints Latex paints Dispersions	117	10°	0.017 / 0.43	100	yellow	662-117
	217	20°	0.017 / 0.43	120	yellow	662-217
	317	30°	0.017 / 0.43	150	yellow	662-317
	417	40°	0.017 / 0.43	190	yellow	662-417
	517	50°	0.017 / 0.43	225	yellow	662-517
	617	60°	0.017 / 0.43	270	yellow	662-617
Rust protection paints Latex paints Dispersions	219	20°	0.019 / 0.48	120	white	662-219
	319	30°	0.019 / 0.48	150	white	662-319
	419	40°	0.019 / 0.48	190	white	662-419
	519	50°	0.019 / 0.48	225	white	662-519
	619	60°	0.019 / 0.48	270	white	662-619
	719	70°	0.019 / 0.48	300	white	662-719
Flame retardant	221	20°	0.021 / 0.53	120	white	662-221
	321	30°	0.021 / 0.53	150	white	662-321
	421	40°	0.021 / 0.53	190	white	662-421
	521	50°	0.021 / 0.53	225	white	662-521
	621	60°	0.021 / 0.53	270	white	662-621
	721	70°	0.021 / 0.53	300	white	662-721
	821	80°	0.021 / 0.53	330	white	662-821

1)Spray width at about 30 cm to the object and 100 bar (10 MPa) pressure with synthetic-resin paint 20 DIN seconds.



All of the tips in the table below are supplied together with the appropriate gun filter.

Application	Tip marking	Spray angle	Bore inch / mm	Spraying width mm 1)	Gun filter	Order no.
Roof coatings	223	20°	0.023 / 0.58	120	white	662-223
	323	30°	0.023 / 0.58	150	white	662-323
	423	40°	0.023 / 0.58	190	white	662-423
	523	50°	0.023 / 0.58	225	white	662-523
	623	60°	0.023 / 0.58	270	white	662-623
	Thick-film materials, Corrosion protection Spray filler	225	20°	0.025 / 0.64	120	white
325		30°	0.025 / 0.64	150	white	662-325
425		40°	0.025 / 0.64	190	white	662-425
525		50°	0.025 / 0.64	225	white	662-525
625		60°	0.025 / 0.64	270	white	662-625
227		20°	0.027 / 0.69	120	white	662-227
327		30°	0.027 / 0.69	150	white	662-327
427		40°	0.027 / 0.69	190	white	662-427
527		50°	0.027 / 0.69	225	white	662-527
627		60°	0.027 / 0.69	270	white	662-627
229		20°	0.029 / 0.75	120	white	662-229
329		30°	0.029 / 0.75	150	white	662-329
429		40°	0.029 / 0.75	190	white	662-429
529		50°	0.029 / 0.75	225	white	662-529
629		60°	0.029 / 0.75	270	white	662-629
231		20°	0.031 / 0.79	120	white	662-231
331		30°	0.031 / 0.79	150	white	662-331
431		40°	0.031 / 0.79	190	white	662-431
531		50°	0.031 / 0.79	225	white	662-531
631		60°	0.031 / 0.79	270	white	662-631
731		70°	0.031 / 0.79	300	white	662-731
831		80°	0.031 / 0.79	330	white	662-831
233		20°	0.033 / 0.83	120	white	662-233
333		30°	0.033 / 0.83	150	white	662-333
433		40°	0.033 / 0.83	190	white	662-433
533		50°	0.033 / 0.83	225	white	662-533
633		60°	0.033 / 0.83	270	white	662-633
235		20°	0.035 / 0.90	120	white	662-235
335		30°	0.035 / 0.90	150	white	662-335
435		40°	0.035 / 0.90	190	white	662-435
535		50°	0.035 / 0.90	225	white	662-535
635		60°	0.035 / 0.90	270	white	662-635
735		70°	0.035 / 0.90	300	white	662-735
439	40°	0.039 / 0.99	190	white	662-439	
539	50°	0.039 / 0.99	225	white	662-539	
639	60°	0.039 / 0.99	270	white	662-639	
Heavy duty applications	443	40°	0.043 / 1.10	190	green	662-443
	543	50°	0.043 / 1.10	225	green	662-543
	643	60°	0.043 / 1.10	270	green	662-643
	445	40°	0.045 / 1.14	190	green	662-445
	545	50°	0.045 / 1.14	225	green	662-545
	645	60°	0.045 / 1.14	270	green	662-645
	451	40°	0.051 / 1.30	190	green	662-451
	551	50°	0.051 / 1.30	225	green	662-551
	651	60°	0.051 / 1.30	270	green	662-651
	455	40°	0.055 / 1.40	190	green	662-455
	555	50°	0.055 / 1.40	225	green	662-555
	655	60°	0.055 / 1.40	270	green	662-655

1) Spray width at about 30 cm to the object and 100 bar (10 MPa) pressure with synthetic-resin paint 20 DIN seconds.

12.5 TR² Tip table

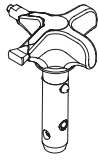

The innovative changeover nozzle from Titan combines two nozzle cores into one nozzle.

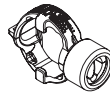

TR² Tip holder

Order no. 0271065

Application	Tip marking (1 / 2)	Spray angle (1 / 2)	Bore 1 inch / mm	Bore 2 inch / mm	Spraying width 1 mm *	Spraying width 2 mm *	Gun filter	Order no.
Cabinets, Furniture and Decks	311/107	30°/10°	0.011 / 0.28	0.007 / 0.18	150	100	red	692-311
	313/109	30°/10°	0.013 / 0.33	0.009 / 0.23	150	100	red	692-313
Doors & Trim	415/111	40°/10°	0.015 / 0.38	0.011 / 0.28	190	100	yellow	692-415
	417/113	40°/10°	0.017 / 0.43	0.013 / 0.33	190	100	white	692-417
Exterior Latex or Oil	515/211	50°/20°	0.015 / 0.38	0.011 / 0.28	225	120	yellow	692-515
Exterior Latex	517/213	50°/20°	0.017 / 0.43	0.013 / 0.33	225	120	white	692-517
	519/213	50°/20°	0.019 / 0.48	0.013 / 0.33	225	120	white	692-519
	521/215	50°/20°	0.021 / 0.53	0.015 / 0.38	225	120	white	692-521
Blockfiller	535/223	50°/20°	0.035 / 0.90	0.023 / 0.58	225	120	green	692-535
	635/327	60°/30°	0.035 / 0.90	0.027 / 0.69	270	150	green	692-635
Diluted joint compound	627/321	60°/30°	0.027 / 0.69	0.021 / 0.53	270	150	green	692-627
	831/321	80°/30°	0.031 / 0.79	0.021 / 0.53	330	150	green	692-831
WideSpray Latex	1223/315	120°/30°	0.023 / 0.58	0.015 / 0.38	540	150	white	692-1223
	1231/317	120°/30°	0.031 / 0.79	0.017 / 0.43	540	150	white	692-1231
Firestop	525/331	50°/30°	0.035 / 0.90	0.031 / 0.79	225	150	green	692-525331

12.6 Additional accessories for 460e

Order no.	Description
580-050	LX-80 spray gun, hose and tip
580-100A	LX-80 II spray gun with 517 tip
316-505	1/4" x 50' airless hose
314-482	LS-10 Liquid Shield™, 1 quart
314-480	Piston Lube™, 8 oz. bottle
0508071	PaintMate, 1 quart