



ALFRA Rotabest Angular Metal Core Drilling Machine V 32



Manual Book



January 2007

1. Technical Data

Prod. – No.:	18710
Name:	ALFRA Rotabest Angular Metal Core Drilling Machine V 32
Input:	900 Watt
Load rpm:	450 rpm
Tool holder:	19 mm Weldon
Coolant supply:	internal, automatically through the spindle
Voltage:	230 V / 110 V (on request)
Magnetic Adhesion:	12000 N

Drilling performance core drills:12 – 32 mm

Cutting Depth:	25 mm
Stroke:	10 – 32 mm
Size of Magnet Foot:	90 x 200 mm (rigid)
Altitude:	227 / 1895 mm
Cable connection:	3,0 m
Weight	12,5 kg

Use ejector pin 6.35 x 70 mm, art.-no. 1924500,only

2. Description

- a) motor
- b) ratched wrench for pre and return stroke
- c) Control panel
- d) Magnet foot
- e) Weldon shank
- f) rack for pre and return stroke
- g) By taking off the handle, the total height can be reduced to 185 mm.
- h) Movable connection for the coolant hose

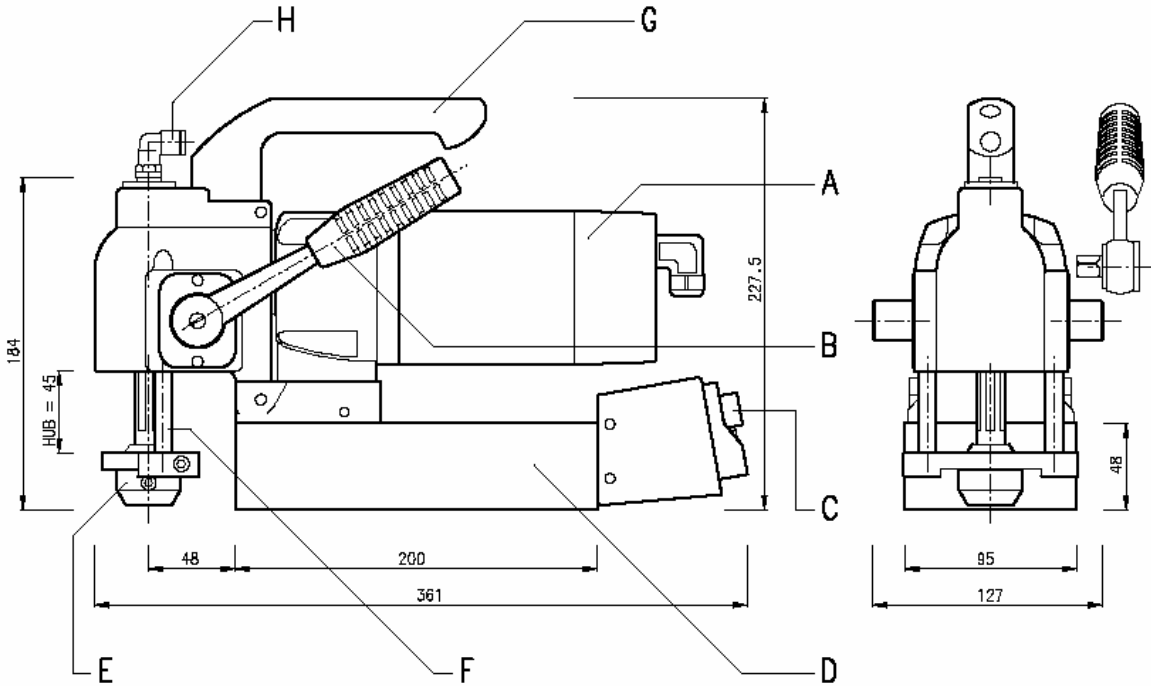

3. Conventional application

This device is destined to:

Cut material with magnetisable surface with core cutters 12 - 32 mm Ø, lower up to 32 mm Ø in sheltered environment for commercial use industry and craft.

This horizontal metal core drilling machine is developed for the pokiest spaces. Perfect to use. where regular Metal Core Drilling Machines have to quit due to their height.

Application areas

Steel construction (in between girder flanges), vehicle constructions (truck frames), bridge construction, tower construction, tunnel construction, tersely every where, where it's poky ...

4. Standard scope of supply

- a) 1 coolant unit with hose and nipple
- b) 1 Transport case
- c) 1 allen wrench for weldon tool holder
- d) 1 Safety Belt
- e) 1 HSS Co core drill Ø 18 mm, cutting depth 25 mm
- f) 1 ejector pin 6.35 x 70 mm (art.-no. 1924500)
- g) 1 Manual Book

5. Prior to use:



Read Operation Manual!



Pay attention to Safety Precautions!

6. Safety Precautions



Danger of Injuries

During drilling operations on walls and ceilings, the Metal Core Drilling Machine must be safeguarded with the included safety belt (f). **The magnetic adhesion is not maintained in case of a failure of circuit.**

The cut core will be ejected automatically by the ejector pin. **Danger of accident! The ejector pin could possibly break in case of improper use.**

Only use undamaged power cord and extension cords and regularly check on damages!

Power supply and voltage details at the device must correspond.

Personal protection equipment

When working with this device, wear the following protection equipment:

Safety goggles, appropriate footwear, ear protection, hair net (for long hair), possibly also apron and safety helmet.

7. Precaution of use

The place of installation for the magnet foot must be clean and rustfree. Remove lacquer- and filler.

For non-magnetisable materials, please use the Rotabest Vacubest (Prod.-No. 18150).

Do not execute any electric welding on the work piece, on which the Metal Core Drilling Machine is used.

Prior to all operations, mount coolant unit.

Danger of injuries! Danger of an electric shock

For operations on walls and ceilings, we recommend cooling with our spray (Alfra BIO 2000, Prod.- No. 21010).

Please note, the magnet adhesive force fails, if the power supply is disconnected (power breakdown, taking out the power plug).

For extending the durability of the core drills, attach the coolant units with hose to the flexible nipple on the V32 and only use a coolant with an adequate viscosity. The drilling core will be cooled down and won't be stuck in the core **drill**.

Please note, when drilling with a material thickness of under 6 mm you need to inferior a steel plate of adequate strength to ensure the full magnetic adhesive force of the magnet foot.

9. Switching on and off



Check supply voltage.

- Check connecting line and plug on damages first!

- Push the red bottom  , in order to initiate the magnet and the magnetic adhesion is guaranteed.

- Push the green bottom  to start the motor.

- To switch off machine proceed in reverse order

red bottom  left = motor off

red bottom  right = magnet off

- When working on walls and ceilings, safe machine with safety belt.

10. Change of tools

How to work with core drills.

- Push ejector pin (center pin) through head of annular cutter.
- Cutters with Weldon shank must be fastened with two setscrews(DIN 913) on both clamping surfaces

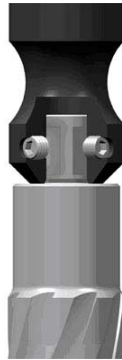

- Replace blunt or twisted ejector pins
- Check the coolant flow.

11. Operating tips

First, place annular cutter with ejector pin on a marked center or marking. Drilling with ALFRA Rotabest cutters does not require much expenditure of force. Set the cutter and spot-drill, until the entire cut **edge is formed as a circle**.

During the drilling process, the cutter should be cooled permanently. Optimal Cooling is possible by internal cooling with our coolant unit.

Drillings up to 10 mm material thickness should be drilled in one operation. When drilling with material thicknesses of 10 mm and up you should disrupt the drilling from time to time and remove the chippings.

Never let the core drill grind without pressure on the material

During the drilling process, do not Stop the motor. After the process, cutter draw back with running motor. You will achieve this by turning over the handle on the rattle.

Remove chips and core after each drilling. Remove chips with Chip-Remover – do not touch with bare hands – **DANGER OF INJURY!**

12. Cleaning

Risk of injury by accidental switching on. Pull plug prior to maintenance work.

Keep the cooling liquid separate from the control box.

Clean and oil lateral guide rods regularly.

Carbon brushes should be replaced after appr. 250 hours running time.

When not in use we recommend to store the Metal Core Drilling Machine V32 in the transport case.

13. Maintenance and repair

a) Maintenance, check and repairs are only to be made by electronics specialists according to the valid regulations of the respective country.

The Metal Core Drilling Machine ALFRA ROTABEST should be serviced after appr. 250 hours running time by our Alfra workshop or appointed dealers.

Only use genuine ALFRA spare parts.





b) ALFRA Service

If you need to service your Metal Core Drilling Machine – No Problem.

Please send your machine together with a short list of defects to our service department. We will check the machine, send you an estimate and repair the machine as quick as possible.

Please call us with your technical questions or questions regarding accessories.

14. Accessories core drills

HSS-Co Eco core drills		HSS-Co RQX	
			
Ø 12	1901012025	Ø 12	1902012025
Ø 13	1901013025	Ø 13	1902013025
Ø 14	1901014025	Ø 14	1902014025
Ø 15	1901015025	Ø 15	1902015025
Ø 16	1901016025	Ø 16	1902016025
Ø 17	1901017025	Ø 17	1902017025
Ø 18	1901018025	Ø 18	1902018025
Ø 19	1901019025	Ø 19	1902019025
Ø 20	1901020025	Ø 20	1902020025
Ø 21	1901021025	Ø 21	1902021025
Ø 22	1901022025	Ø 22	1902022025
Ø 23	1901023025	Ø 23	1902023025
Ø 24	1901024025	Ø 24	1902024025
Ø 25	1901025025	Ø 25	1902025025
Ø 26	1901026025	Ø 26	1902026025
Ø 27	1901027025	Ø 27	1902027025
Ø 28	1901028025	Ø 28	1902028025
Ø 29	1901029025	Ø 29	1902029025
Ø 30	1901030025	Ø 30	1902030025
Ø 31	1901031025	Ø 31	1902031025
Ø 32	1901032025	Ø 32	1902032025
Center and ejector pin, art-no. 1924500			
	ALFRA Magnetic Chip Remover, art. no. 18654		
	Vacuum Attachment Vacubest, art. no. 18150		

15. Garantie

For our ALFRA Rotabest Metal Core Drilling Machines we grant guarantee according to the legal and regional regulations (proven by invoice).

16. CE Declaration of Conformity

We declare in our exclusive responsibility, that this product correspond to the following standards and specifications:

Specification 89/392/EWG, 91/368/EWG

DIN EN 292 T.1 u. 2

DIN EN 90204 T.1

DIN VDE 0740 T

The proof of an electromagnetic compatibility took place according the appropriate EC-Specification 89/336/EWG after the following norms:

EN 61000-3-2:1995/A1:1998/A2:1998

EN 61000-3-3: 1995

EN 55014-1: 1993/A1: 1997 55014-2: 1997

If the electric tool is modified without our authorization, this declaration will lose its validity and the guarantee expires.

The sound pressure level at the work place might exceed 85 dp(A). In case the user must wear hearing protectors.

Technical changes and drawings

ALFRA Rotabest Metal Core Drilling Machines are adjusted to the latest technical standards. Thus we reserve the right to change technical data. Also drawings are noncommittal.

17. Spare Parts

ALFRA pioneer in metal core drilling – 25 years of experience.