

ELEKTROWERKZEUGE

GE 5

GE 5 R

GSE 5

GSE 5 R

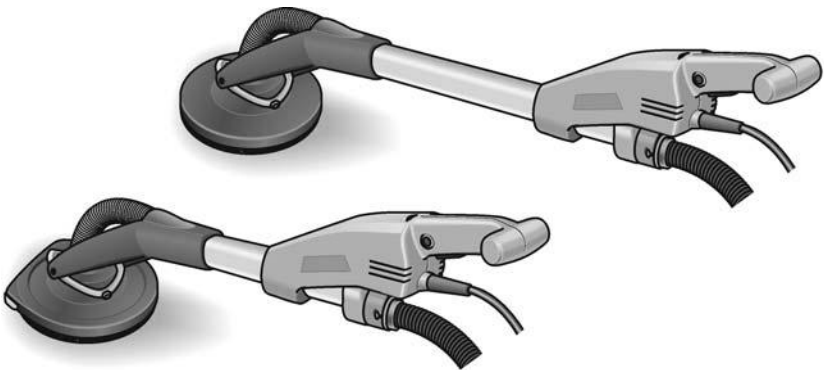

de	Originalbetriebsanleitung	3
en	Original operating instructions	15
fr	Notice d'instructions d'origine	26
it	Istruzioni per l'uso originali	38
es	Instrucciones de funcionamiento originales	50
pt	Instruções de serviço originais	62
nl	Originale gebruiksaanwijzing	74
da	Originale driftsvejledning	86
no	Originale driftsanvisningen	98
sv	Originalbruksanvisning	109
fi	Alkuperäinen käyttöohjekirja	120
el	Αυθεντικές οδηγίες χειρισμού	131
tr	Orijinal işletme kılavuzu	143
pl	Instrukcja oryginalna	154
hu	Eredeti üzemeltetési útmutató	166
cs	Originální návod k obsluze	178
sk	Originálny návod na obsluhu	189
hr	Originalna uputa za rad	200
sl	Izvirno navodilo za obratovanje	211
ro	Instrucțiuni de funcționare originale	222
bg	Оригинално упътване за експлоатация	234
ru	Оригинальная инструкция по эксплуатации	246
et	Originaalkasutusjuhend	259
lt	Originali naudojimo instrukcija	270
lv	Lietošanas pamācības oriģināls	281
ar	ترجمة لإرشادات التشغيل الأصلية	301

Contents

Symbols used in this manual	15
Symbols on the power tool	15
For your safety	15
Noise and vibration	18
Disposal information	18
CE-Declaration of Conformity	18
Overview	19
Technical specifications	20
Instructions for use	21
Instructions for use	23
Operating instructions	23
Maintenance and care	24
Exemption from liability	25

Symbols used in this manual

WARNING!

Denotes impending danger.
Non-observance of this warning may result in death or extremely severe injuries.

CAUTION!

Denotes a possibly dangerous situation.
Non-observance of this warning may result in slight injury or damage to property.

NOTE

Denotes application tips and important information.

Symbols on the power tool



Before switching on the power tool, read the operating manual!



Wear goggles!



Disposal information for the old machine (see page 18)!

For your safety



WARNING!

Before using the power tool, please read and follow:

- these operating instructions,
- the “General safety instructions” on the handling of power tools in the enclosed booklet (leaflet-no.: 315.915),
- the currently valid site rules and the regulations for the prevention of accidents.

This power tool is state of the art and has been constructed in accordance with the acknowledged safety regulations. Nevertheless, when in use, the power tool may be a danger to life and limb of the user or a third party, or the power tool or other property may be damaged.

The power tool may be operated only if it is

- as intended,
- in perfect working order.

Faults which impair safety must be repaired immediately.

Intended use

The wall sander GE 5/GE 5 R/GSE 5/GSE 5 R is designed

- for commercial use in industry and trade,
- for sanding walls and ceilings inside and outside,
- for sanding smoothed drywalls,
- for use with tools which FLEX offer for these power tools and which are authorised to run at a speed of at least 1750 r.p.m.

It is not permitted to use cutting-off wheels, roughing wheels, fan-like grinding wheels or wire brushes.

When using the wall sander GE 5/GE 5 R/GSE 5/GSE 5 R, connect a Class M dust extractor.

Safety instructions

WARNING!

Read all safety warnings and all instructions. Failure to follow the warnings and instructions may result in electric shock, fire and/or serious injuries. Save all warnings and instructions for future reference.

- **This power tool is intended to function as a sander. Read all safety warnings, instructions, illustrations and specifications provided with this power tool.** Failure to follow all instructions listed below may result in electric shock, fire and/or serious injury.
- **Operations such as grinding, wire brushing, or for polishing and cut-off are not recommended to be performed with this power tool.**
Operations for which the power tool was not designed may create a hazard and cause personal injury.
- **Do not use accessories which are not specifically designed and recommended by the tool manufacturer.**
Just because the accessory can be attached to your power tool, it does not assure safe operation.
- **The rated speed of the accessory must be at least equal to the maximum speed marked on the power tool.**
Accessories running faster than their rated speed can break and fly apart.
- **The outside diameter and the thickness of your accessory must be within the capacity rating of your power tool.**
Incorrectly sized accessories cannot be adequately guarded or controlled.
- **Threaded mounting of accessories must match the grinder spindle thread. For accessories mounted by flanges, the arbour hole of the accessory must fit the locating diameter of the flange.**
Accessories that do not match the mounting hardware of the power tool will run out of balance, vibrate excessively and may cause loss of control.
- **Do not use a damaged accessory. Before each use inspect the accessory such as abrasive wheels for chips and cracks, backing pad for cracks, tear or excess wear, wire brush for loose or cracked wires. If power tool or accessory is dropped, inspect for damage or install an undamaged accessory. After inspecting and installing an accessory, position yourself and bystanders away from the plane of the rotating accessory and run the power tool at maximum no-load speed for one minute.** Damaged accessories will normally break apart during this test time.
- **Wear personal protective equipment. Depending on application, use face shield, safety goggles or safety glasses. As appropriate, wear dust mask, hearing protectors, gloves and shop apron capable of stopping small abrasive or workpiece fragments.** The eye protection must be capable of stopping flying debris generated by various operations. The dust mask or respirator must be capable of filtering particles generated by your operation. Prolonged exposure to high intensity noise may cause hearing loss.
- **Keep bystanders a safe distance away from work area. Anyone entering the work area must wear personal protective equipment.**
Fragments of workpiece or of a broken accessory may fly away and cause injury beyond immediate area of operation.
- **Hold power tool by insulated gripping surfaces only, when performing an operation where the cutting accessory may contact hidden wiring or its own cord.** Cutting accessory contacting a "live" wire may make exposed metal parts of the power tool "live" and shock the operator.
- **Position the cord clear of the spinning accessory.**
If you lose control, the cord may be cut or snagged and your hand or arm may be pulled into the spinning accessory.
- **Never lay the power tool down until the accessory has come to a complete stop.** The spinning accessory may grab the surface and pull the power tool out of your control.
- **Do not run the power tool while carrying it at your side.** Accidental contact with the spinning accessory could snag your clothing, pulling the accessory into your body.

- **Regularly clean the power tool's air vents.**
The motor's fan will draw the dust inside the housing and excessive accumulation of powdered metal may cause electrical hazards.
- **Do not operate the power tool near flammable materials.**
Sparks could ignite these materials.
- **Do not use accessories that require liquid coolants.**
Using water or other liquid coolants may result in electrocution or shock.

Kickback and Related Warnings

Kickback is a sudden reaction to a pinched or snagged rotating wheel, backing pad, brush or any other accessory. Pinching or snagging causes rapid stalling of the rotating accessory which in turn causes the uncontrolled power tool to be forced in the direction opposite of the accessory's rotation at the point of the binding.

For example, if an abrasive wheel is snagged or pinched by the workpiece, the edge of the wheel that is entering into the pinch point can dig into the surface of the material causing the wheel to climb out or kick out. The wheel may either jump toward or away from the operator, depending on direction of the wheel's movement at the point of pinching. Abrasive wheels may also break under these conditions.

Kickback is the result of power tool misuse and/or incorrect operating procedures or conditions and can be avoided by taking proper precautions as given below.

- **Maintain a firm grip on the power tool and position your body and arm to allow you to resist kickback forces.**
Always use auxiliary handle, if provided, for maximum control over kickback or torque reaction during start-up.
The operator can control torque reactions or kickback forces, if proper precautions are taken.
- **Never place your hand near the rotating accessory.**
Accessory may kickback over your hand.

- **Do not position your body in the area where power tool will move if kickback occurs.**
Kickback will propel the tool in direction opposite to the wheel's movement at the point of snagging.
- **Use special care when working corners, sharp edges etc. Avoid bouncing and snagging the accessory.**
Corners, sharp edges or bouncing have a tendency to snag the rotating accessory and cause loss of control or kickback.
- **Do not attach a saw chain woodcarving blade or toothed saw blade.**
Such blades create frequent kickback and loss of control.

Special safety instructions for sanding

- **Do not use excessively oversized sanding disc paper. Follow manufacturers recommendations, when selecting sanding paper.**
Larger sanding paper extending beyond the sanding pad presents a laceration hazard and may cause snagging, tearing of the disc or kickback.

Additional safety instructions

- Use only extension cables permitted for outdoor use.
- It is not recommended to sand lead paint. Lead paint should be removed by a specialist only.
- If plaster board or plaster is sanded, this may cause static electricity to build up on the tool. To ensure your safety, the wall sander is earthed. Remove dust with an earthed dust extractor only.
- Do not work on materials which release hazardous substances (e.g. asbestos). Take precautions if hazardous, combustible or explosive dust is likely to occur. Wear protective dust mask. Use dust extraction system.



Damage to property!

- The mains voltage and the voltage specifications on the rating plate must correspond.

Noise and vibration

NOTE

Values for the A-weighted sound pressure level and for the total vibration values can be found in the "Technical specifications" table. The noise and vibration values have been determined in accordance with EN 60745.

CAUTION!

The indicated measurements refer to new power tools. Daily use causes the noise and vibration values to change.

NOTE

The vibration emission level given in this information sheet has been measured in accordance with a standardised test given in EN 60745 and may be used to compare one tool with another. It may be used for a preliminary assessment of exposure. The declared vibration emission level represents the main applications of the tool. However if the tool is used for different applications, with different accessories or poorly maintained, the vibration emission may differ. This may significantly increase the exposure level over the total working period. However if the tool is used for different applications, with different accessories or poorly maintained, the vibration emission may differ. This may significantly decrease the exposure level over the total working period. Identify additional safety measures to protect the operator from the effects of vibration such as: maintain the tool and the accessories, keep the hands warm, organisation of work patterns.

CAUTION!

Wear ear protection at a sound pressure above 85 dB(A).

Disposal information

WARNING!

Render redundant power tools unusable by removing the power cord.



EU countries only

Do not throw electric power tools into the household waste!

In accordance with the European Directive 2012/19/EU on Waste Electrical and Electronic Equipment and transposition into national law used electric power tools must be collected separately and recycled in an environmentally friendly manner.

NOTE

Please ask your dealer about disposal options!

CE-Declaration of Conformity

We declare under our sole responsibility that the product described under "Technical specifications" conforms to the following standards or normative documents:

EN 60745 in accordance with the regulations of the directives 2014/30/EU, 2006/42/EC, 2011/65/EU.

Responsible for technical documents:
FLEX-Elektrowerkzeuge GmbH, R & D
Bahnhofstrasse 15, D-71711 Steinheim/Murr

Eckhard Rühle
Manager Research &
Development (R & D)

Klaus Peter Weinper
Head of Quality
Department (QD)

26.09.2018

FLEX-Elektrowerkzeuge GmbH
Bahnhofstrasse 15, D-71711 Steinheim/Murr

Overview

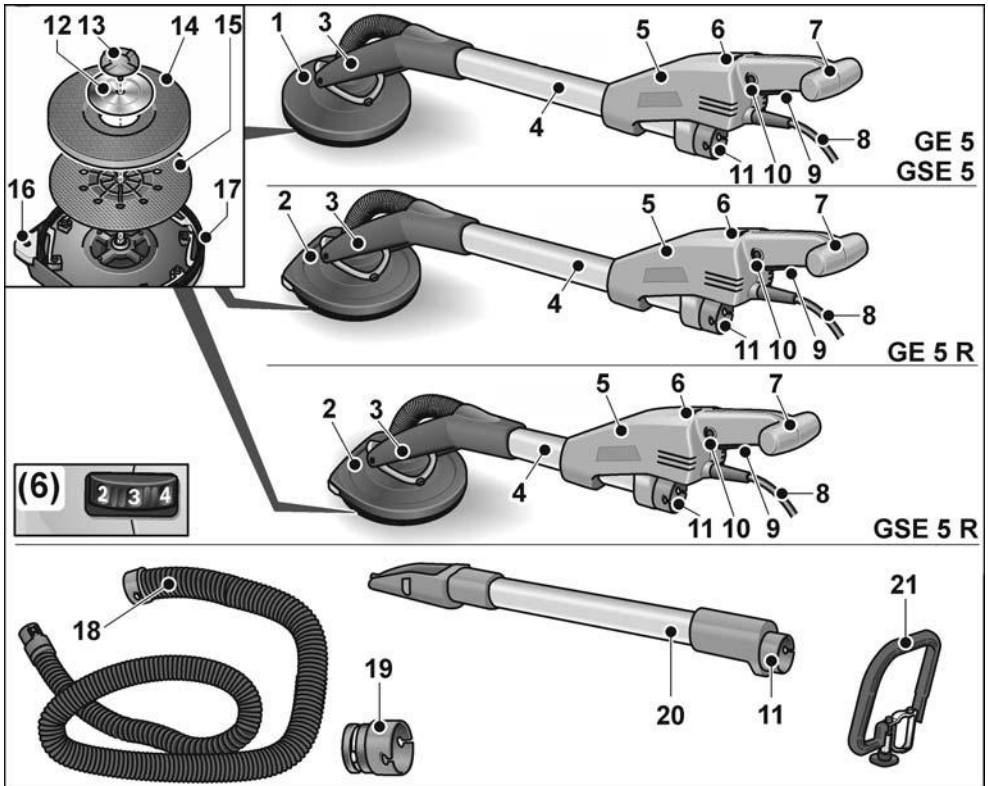

- | | |
|--|--|
| <p>1 Sanding head (GE 5/GSE 5)
with closed brush ring</p> <p>2 Sanding head (GE 5 R/GSE 5 R)
with open brush ring for sanding edges</p> <p>3 Gimbal bearings</p> <p>4 Tubular handle</p> <p>5 Housing</p> <p>6 Dial for preselecting the speed</p> <p>7 Handle</p> <p>8 5.0 m power cord with plug</p> <p>9 Switch</p> <p>10 Locking button</p> <p>11 32 mm connection</p> | <p>12 Retaining washer</p> <p>13 Screw</p> <p>14 Velcro pad</p> <p>15 Backing pad</p> <p>16 Replaceable protective corners
(GE 5 R/GSE 5 R)</p> <p>17 Brush ring</p> <p>18 Suction hose</p> <p>19 Adapter for extraction hose (optional)
for connection of electric power tools
using conventional connection piece</p> <p>20 Extension tube (optional)</p> <p>21 Bail handle (optional)</p> |
|--|--|

Technical specifications

Machine type		Wall sander			
		GE 5	GE 5 R	GSE 5	GSE 5 R
Mains voltage	V/Hz	230/50			
Protection class		I			
Power input	W	500			
Speed	r.p.m.	1100–1650			
Max. disc diameter	mm	225			
Length	mm	1520		1160	
Suction hose/length x diameter	mm	4000 x 32			
Weight (without power cord and backing pad)	kg	3.9		3.6	
A-weighted sound pressure level according to EN 60745 (see "Noise and vibration"):					
Sound pressure level L_{pA}	dB(A)	79			
Sound power level L_{WA}	dB(A)	90			
Uncertainty K	dB	3			
Total vibration value according to EN 60745 (see "Noise and vibration"):					
Emmission value a_h when sanding smoothed plasterboard walls	m/s^2	< 2.5			
Uncertainty K	m/s^2	1.5			

Instructions for use

Before switching on the power tool

Unpack power tool and accessories and check that no parts are missing or damaged.

Connecting the extractor

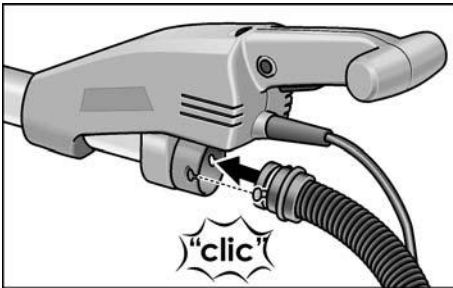

- Connect extraction hose to the 32 mm connector.

i NOTE

The connection piece of the GE 5/GE 5 R/ GSE 5/GSE 5 R is a new development. If electric power tools are used with conventional connection pieces together with the extraction hose of the GE 5/GE 5 R/ GSE 5/GSE 5 R, an adapter from the FLEX accessories programme can be used.

Using a dust extraction system

! CAUTION!

- When using the wall sander, connect a Class M dust extractor.
- If a dust bag is used which is not authorised for use with dry construction dust, the amount of dust particles in the air may increase at the work place. Over a prolonged period high concentrations of dust in the air may damage the human respiratory system.
- Insert the special dust bag for dry construction dust into your dust extractor according to the instructions supplied with the dust extractor.

- Connect extraction hose to the dust extraction system. Follow the operating instructions for the dust extraction system! Check the attachment! If required, use an appropriate adapter.

i NOTE

If your dust extractor requires a special connector, the clip-on connection can be removed and a matching adapter selected from the FLEX accessories range.

Attaching and changing the sanding tools

! CAUTION!

Before performing any work on the electric power tool, pull out the mains plug.

- Remove worn sanding tool from the Velcro pad.

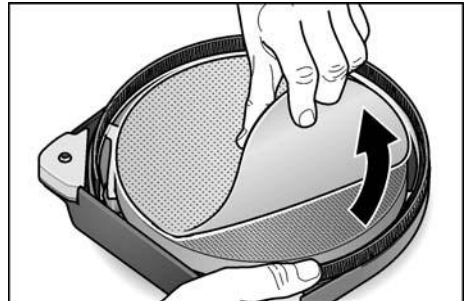

- Place the sanding sheet in the centre of the Velcro pad and press on.
- Conduct a test run to check that the sanding tool is clamped in the centre.

! CAUTION!

Never use the Velcro pad as a sanding tool. Never use the wall sander without the sanding sheet, otherwise the work surface will be seriously damaged!

Switching the electric power tool on and off

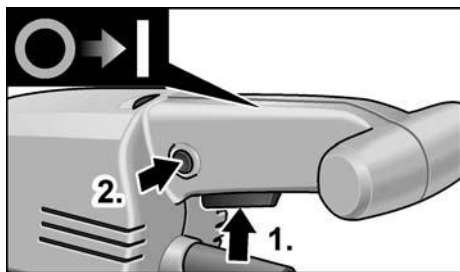

Switch on the machine:

- Press the switch (1.).
- To engage, press the locking button and release switch (2.).

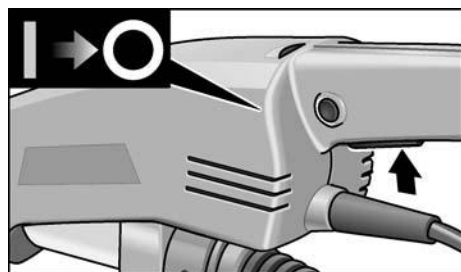

Switch off the machine:

- Press the switch briefly

Preselecting the speed

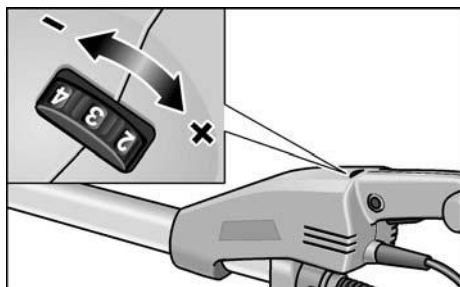

To set the operating speed, move the dial to the required value.

Using extension (optional)

An extension tube is available for the wall sander GE 5/GE 5 R/GSE 5/GSE 5 R.

The extension tube can be used to increase the range when working with the wall sander.

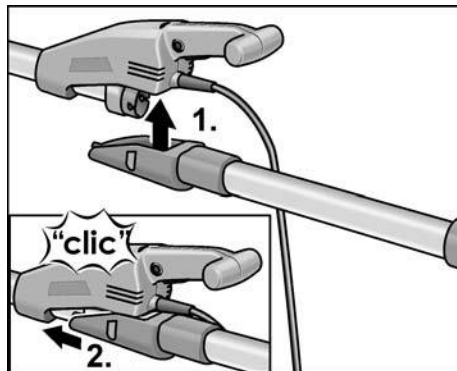

- Attach extension tube from below to the housing of the wall sander (1.) and push it forwards until it engages (2.).

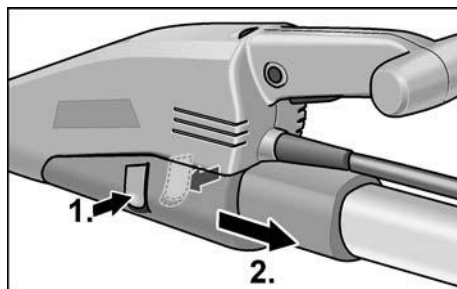

- To remove, press in both catches (1.) and remove extension tube (2.).

Working with the power tool

⚠ CAUTION!

Hold the electric power tool with both hands! When working, always have one hand on the handle – even when working with attached extension. Keep your hands away from the sanding head.

Otherwise, your hand could become caught, as the sanding head swivels in different directions.

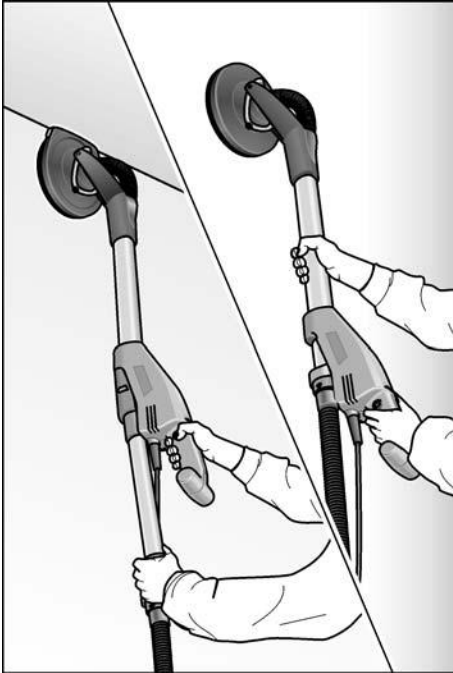

1. Attach sanding tool.
2. Connect dust extraction system.
3. Insert mains plug.
4. Set required speed.
5. Switch on dust extraction system.
6. Hold the wall sander with both hands. This provides the best possible combination of range and leverage for the application.
7. Switch on the device.
8. Press the wall sander gently against the work surface (the pressure should be just enough to ensure that the sanding head is flush with the work surface).
9. Increase the pressure to bring the sanding sheet into contact with the work surface. In doing so, swing the sander in overlapping movements to smooth the surface to the required fineness.

CAUTION!

The rotating parts of the sanding head must not come into contact with sharp projecting objects (e.g. nails, screws, junction boxes). The Velcro pad may be damaged if it comes into contact with projecting objects.

The Velcro pad can be replaced if it is damaged or severely abraded (see section entitled "Maintenance and care").

Operating instructions

Brush ring

A brush-type ring surrounds the sanding head. This ring has two functions:

- As the ring projects above the surface of the sanding plate, it is the ring which comes into contact with the work surface first. As a result, the sanding head is brought parallel to the work surface before the sanding tool comes into contact with the work surface.

This avoids a sickle-shaped depression caused by the edge of the sanding disc.

- The ring also retains the dust until it is extracted by the dust extractor.

If the brush ring is damaged or shows excessive wear, it should be replaced (see section entitled "Maintenance and care"). Replacement brush rings are available from any FLEX customer service centre.

Sanding in dry construction

The wall sander features a unique swivel head. As this head can swivel in different directions, the sanding head can be adjusted to the work surface.

As a result, the user can sand the upper, middle and lower wall areas or ceiling profiles without having to change his position.

When working, apply only as much pressure as is required to keep the sanding plate in contact with the work surface. Excessive pressure may result in a disagreeable spiral pattern of scratches and an uneven work surface.

Move the sander constantly while the sanding plate is in contact with the work surface. In doing so, ensure that you move the sander evenly and over a wide area.

If you stop the sander on the work surface or move the sander unevenly, this may result in a disagreeable spiral pattern of scratches and an uneven work surface.

i NOTE

The wall sander features an overload cut-out for protecting the device. If the load is too great, the device switches off and immediately restarts.

Maintenance and care

⚠ WARNING!

Before performing any work, pull out the mains plug.

Cleaning

⚠ WARNING!

Do not use water or liquid detergents.

- Regularly blow out the housing interior and motor with dry compressed air.
- Blow out the sanding head and gimbal bearing with dry compressed air.

Replacing Velcro or backing pad

- Take hold of the sanding plate together with the sanding head to prevent the sanding plate from turning.

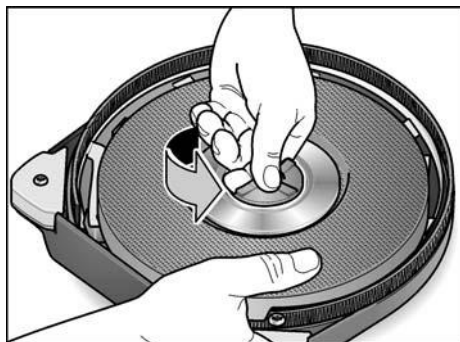

- Turn the screw in an anti-clockwise direction and remove.
- Disassemble the sanding head.

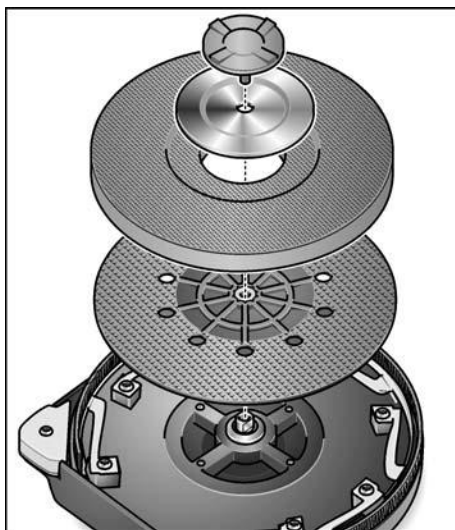

- Replace parts.
- Assemble sanding head in reverse sequence.

Replacing the brush ring

- Remove the sanding head (see section "Replacing Velcro or backing pad").

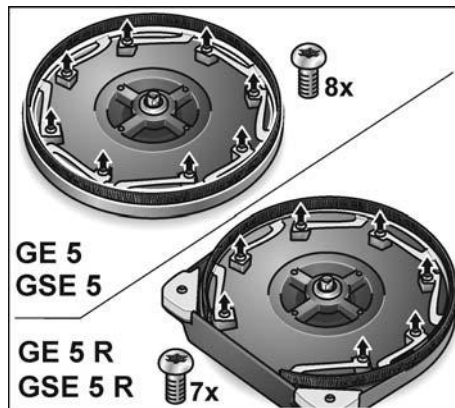

- Loosen the retaining screws.
- Take the ring out of the housing.
- Insert a new brush ring into the housing and screw in the retaining screws.
- Assemble sanding head in reverse sequence.

Replacing the protective corners (GE 5 R/GSE 5 R)

- Remove protective corners to be replaced.

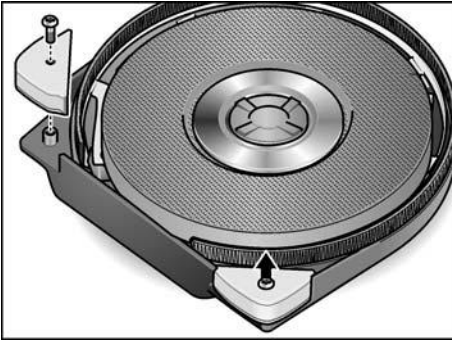

- Attach new protective corners.

Repairs

Repairs may be carried out by an authorised customer service centre only.

i NOTE

During the warranty period do not loosen the screws on the housing.

Non-compliance will deem the guarantee obligations of the manufacturer null and void.

Spare parts and accessories

Other accessories, in particular insertion tools, can be found in the manufacturer's catalogues.

Exploded drawings and spare-part lists can be found on our homepage:

www.flex-tools.com

Exemption from liability

The manufacturer and his representative are not liable for any damage and lost profit due to interruption in business caused by the product or by an unusable product. The manufacturer and his representative are not liable for any damage which was caused by improper use of the product or by use of the product with products from other manufacturers.

FLEX-Elektrowerkzeuge GmbH
Bahnhofstr. 15
71711 Steinheim/Murr

Tel. +49 (0) 7144 828-0
Fax +49 (0) 7144 25899

info@flex-tools.com
www.flex-tools.com
