



MARKKONE ACCESS

ACCESS

Scissor Lifts
Low Level Access
Boom Lifts
Towable Boom Lifts
Access Towers
Steps, Ladders & Platforms

ACCESS SPECIALIST TEAM **01702 561820**

www.mark1access.co.uk

POWERED ACCESS TROUBLE SHOOTING

PROBLEM: WORKING CONDITIONS	Slopes, uneven ground, potholes, loose terrain and steep inclines
SOLUTION	4x4 tracked machines with stabilizer legs
HOW IT WORKS	4x4 means drive to all four wheels creating more traction to get through the roughest of terrain. Stabilizer legs can be deployed and level the machine before ascending
MACHINES TO CONSIDER	SD120T • TD120T • RT scissor lifts

PROBLEM: OBSTRUCTIONS	Girders, overhangs, conservatories and fencing.
SOLUTION	Boom lifts - articulated with a jib arm
HOW IT WORKS	Articulated boom lifts enable user to go up and over most obstacles and the jib arm allows you to get into those tight spaces
MACHINES TO CONSIDER	HR17 • HR17N • HR21

PROBLEM: CONFINED SPACES	Narrow single doorways, tight alleyways and between warehouse racking
SOLUTION	Narrow scissor lifts or narrow boom lifts
HOW IT WORKS	Narrow access machines have a much smaller width than standard enabling the user to get through single doorways and access those tight gaps
MACHINES TO CONSIDER	GR15 • GR20 • 19' scissor • 26'N scissor • Star10 • HR12N • HR17N

PROBLEM: NOISE LEVELS	Low noise constraints, early morning work and night work
SOLUTION	Hybrid or electric machines
HOW IT WORKS	Electric access machines run off battery power causing very low noise levels. Hybrid technology gives you both diesel and electric options
MACHINES TO CONSIDER	All electric scissors and hybrid booms

PROBLEM: WEIGHT RESTRICTIONS	Mezzanine floors, delicate floors, tiled floors and weight restricted elevators
SOLUTION	Low weight access machines under 1Ton
HOW IT WORKS	Light weight access machines are built specifically for this job. Ideal for 1 person and compact and light weight enough to go in a lift or be pushed into the working area
MACHINES TO CONSIDER	AWP25S • AWP30S • Power Towers • Nano SP • GR15

PROBLEM: EMISSIONS	Green sites, LEZ zones and no pollution
SOLUTION	Hybrid or electric machines
HOW IT WORKS	Hybrid machines have the capability to work in just battery mode where in the past this has only been achievable with a diesel only engine
MACHINES TO CONSIDER	All electric scissors and hybrid booms

PROBLEM: NO MESS	Valuable floors, antique floors, precious stone tiles and laboratories
SOLUTION	Non marking tyre machine and/or wheel protection covers
HOW IT WORKS	All of our electric machines come with non marking tyres as standard. We also stock wheel covers that can be easily fitted to each machine
MACHINES TO CONSIDER	All electric scissors and hybrid booms



CONTENTS



SCISSOR LIFTS	4
LOW LEVEL ACCESS	11
BOOM LIFTS	14
TOWABLE BOOM LIFTS	20
ACCESS TOWERS	23
STEPS, LADDERS AND PLATFORMS	27
CERTIFIED TRAINING	30



Why choose Mark One?

- ✓ Unrivalled customer service
- ✓ Helpful, knowledgeable team
- ✓ Equipment you can rely on
- ✓ Prompt delivery and collection
- ✓ 20% off 4 week hires
- ✓ Dedicated training facilities
- ✓ Easy payment options
- ✓ Specialist departments



contact us:

ACCESS
SPECIALIST TEAM
01702 561820

online at:
www.mark1access.co.uk



SCISSOR LIFTS

For straight up and down working, scissor lifts provide the ideal solution, transporting users and their tools to an elevated work place quickly and safely.

BENEFITS

- Excellent manoeuvrability
- Control box allowing user to control from ground or cage
- Low noise levels
- Non-marking tyres
- Electric and diesel available

SAFETY FEATURES

- Tilt sensor with audible alarm
- Emergency stop switch at both platform and ground controls
- Heavy duty steel guardrails
- Pothole guards
- Roll out platform extension
- Built-in lanyard attachment
- Solid steel deck with slip-resistant surface
- Emergency manual platform lowering valve

WHEN HIRING YOU WILL BE PROVIDED WITH:

- A Certificate of Thorough Examination (LOLER)
- Operators Instruction Manual

Plus documented Handover Familiarisation to ensure you fully understand:

- Basic functions of the unit
- Pre-operational safety checks and maintenance
- Setting up procedure
- Site conditions and safety

Please note that Handover Familiarisation is not a replacement for training in the correct use of powered access equipment.



19' SCISSOR LIFT

TECHNICAL SPECIFICATION

	Metric
Working Height:	7.8 m
Platform Height:	5.8 m
Height Stowed (Guardrails down):	1.75 m
Height Stowed (Guardrails up):	2.10 m
Length:	1.78 m
Width:	0.81 m
Ground Clearance:	6 cm
Ground Clearance - Pothole Protectors Deployed	1.78 cm
Platform Length - Stowed:	1.63 m
Platform Length - Extended (Deck out):	2.54 cm
Platform Width (Inside):	0.66 m
Lift Capacity:	227 kg
Extension Deck Lift Capacity:	113 kg
Turning Radius Outside:	1.68 m
Turning Radius Inside:	zero
Power Source:	Battery
Tyres:	Solid Non-marking Rubber
Gradeability:	25 %
Weight:	1,312 kg
Maximum Number of People:	2+ tools

CODE: 350100

FOR INTERNAL AND EXTERNAL USE
SOLID FLAT SURFACE ONLY

HIRE RATES

Code	1 day	+1 day	1 week	4 weeks
350100	£99.00	£28.00	£155.00	£124.00*

Long term hire rates must be agreed at the time of hire *price per week



26' NARROW SCISSOR LIFT

TECHNICAL SPECIFICATION

	Metric
Working Height:	9.92 m
Platform Height:	7.92 m
Height Stowed (Guardrails down):	1.91 m
Height Stowed (Guardrails up):	2.25 m
Length:	2.32 m
Width:	0.84 m
Ground Clearance:	8.89 cm
Ground Clearance - Pothole Protectors Deployed	1.9 cm
Platform Length - Stowed:	2.13 m
Platform Length - Extended (Deck out):	3.04 m
Platform Width (Inside):	0.71 m
Lift Capacity:	227 kg
Extension Deck Lift Capacity:	113 kg
Turning Radius Outside:	2.74 m
Turning Radius Inside:	1.27 m
Power Source:	Battery
Tyres:	Solid Non-marking Rubber
Gradeability:	30 %
Weight:	1,890 kg
Maximum Number of People:	2+ tools

CODE: 350125

FOR INTERNAL USE ONLY
SOLID FLAT SURFACE ONLY

HIRE RATES

Code	1 day	+1 day	1 week	4 weeks
350125	£125.00	£35.00	£195.00	£156.00*

Long term hire rates must be agreed at the time of hire *price per week



WARNING - EQUIPMENT SPECIFICATION MAY VARY SLIGHTLY. IF IN DOUBT PLEASE PHONE TO CHECK.

All prices shown exclude VAT. Long term rates must be agreed at time of hire.



26' SCISSOR LIFT

TECHNICAL SPECIFICATION

	Metric
Working Height:	9.92 m
Platform Height:	7.92 m
Height Stowed (Guardrails down):	1.89 m
Height Stowed (Guardrails up):	2.25 m
Length:	2.31 m
Width:	1.17 m
Ground Clearance:	8.89 cm
Ground Clearance - Pothole Protectors Deployed	1.91 cm
Platform Length - Stowed:	2.13 m
Platform Length - Extended (Deck out):	3.35 m
Platform Width (Inside):	1.07 m
Lift Capacity:	454 kg
Extension Deck Lift Capacity:	136 kg
Turning Radius Outside:	2.37 m
Turning Radius Inside:	1.21 m
Power Source:	Battery
Tyres:	Solid Non-marking Rubber
Gradeability:	30 %
Weight:	2,170 kg
Maximum Number of People:	3+ tools

CODE: 350120

FOR INTERNAL AND EXTERNAL USE
SOLID FLAT SURFACE ONLY

HIRE RATES

Code	1 day	+1 day	1 week	4 weeks
350120	£125.00	£35.00	£195.00	£156.00*

Long term hire rates must be agreed at the time of hire *price per week



32' SCISSOR LIFT

TECHNICAL SPECIFICATION

	Metric
Working Height:	11.75 m
Platform Height:	9.75 m
Height Stowed (Guardrails down):	1.99 m
Height Stowed (Guardrails up):	2.35 m
Length:	2.31 m
Width:	1.17 m
Ground Clearance:	8.89 cm
Ground Clearance - Pothole Protectors Deployed	1.91 cm
Platform Length - Stowed:	2.13 m
Platform Length - Extended (Deck out):	3.35 m
Platform Width (Inside):	1.07 m
Lift Capacity:	317 kg
Extension Deck Lift Capacity:	113 kg
Turning Radius Outside:	2.37 m
Turning Radius Inside:	1.21 m
Power Source:	Battery
Tyres:	Solid Non-marking Rubber
Gradeability:	25 %
Weight:	2,300 kg
Maximum Number of People:	2+ tools

CODE: 350130

FOR INTERNAL AND EXTERNAL USE
SOLID FLAT SURFACE ONLY

HIRE RATES

Code	1 day	+1 day	1 week	4 weeks
350130	£140.00	£52.50	£245.00	£192.00*

Long term hire rates must be agreed at the time of hire *price per week



WARNING - EQUIPMENT SPECIFICATION MAY VARY SLIGHTLY. IF IN DOUBT PLEASE PHONE TO CHECK.

All prices shown exclude VAT. Long term rates must be agreed at time of hire.

40' SCISSOR LIFT

TECHNICAL SPECIFICATION

	Metric
Working Height:	13.8 m
Platform Height:	11.8 m
Height Stowed (Guardrails down):	2.21 m
Height Stowed (Guardrails up):	2.48 m
Length:	2.4 m
Width:	1.19 m
Ground Clearance:	8.1 cm
Ground Clearance - Pothole Protectors Deployed:	1.9 cm
Platform Length - Stowed:	2.19 m
Platform Length - Extended:	3.35 m
Platform Width (Inside):	1.06 m
Lift Capacity:	350 kg
Turning Radius Outside:	2.58 m
Turning Radius Inside:	0.54 m
Tyres:	Solid Non-marking Rubber
Gradeability:	25%
Power Source:	Battery
Weight:	2,985 kg
Maximum Number of People:	3+ tools

CODE: 350135

FOR INTERNAL AND EXTERNAL USE
SOLID FLAT SURFACE ONLY

HIRE RATES

Code	1 day	+1 day	1 week	4 weeks
350135	£175.00	£60.00	£295.00	£236.00*

Long term hire rates must be agreed at the time of hire *price per week



26' ROUGH TERRAIN 4X4 DIESEL SCISSOR LIFT

TECHNICAL SPECIFICATION

	Metric
Working Height:	9.92 m
Platform Height:	7.92 m
Height Stowed (Guardrails down):	1.61 m
Height Stowed (Guardrails up):	2.37 m
Length:	3.35 m
Width:	1.76 m
Ground Clearance:	0.2 m
Platform Length - Stowed:	2.44 m
Platform Length - Extended (Deck out):	3.96 m
Platform Width (Inside):	1.42 m
Lift Capacity:	567 kg
Deck Extension:	1.52 m
Turning Radius Outside:	3.96 m
Turning Radius Inside:	1.52 m
Tyres:	Rough Terrain Rubber
Gradeability:	50%
Power Source:	Diesel
Weight:	3,305 kg
Maximum Number of People:	4+ tools

CODE: 350180

MACHINE HAS 4X4
SELF LEVELLING JACK LEGS

HIRE RATES

Code	1 day	+1 day	1 week	4 weeks
350180	£145.00	£55.00	£255.00	£204.00*

Long term hire rates must be agreed at the time of hire *price per week



WARNING - EQUIPMENT SPECIFICATION MAY VARY SLIGHTLY. IF IN DOUBT PLEASE PHONE TO CHECK.

All prices shown exclude VAT. Long term rates must be agreed at time of hire.





32' ROUGH TERRAIN 4X4 DIESEL SCISSOR LIFT

TECHNICAL SPECIFICATION

	Metric
Working Height:	11.75 m
Platform Height:	9.75 m
Height Stowed (Guardrails down):	1.75 m
Height Stowed (Guardrails up):	2.51 m
Length:	3.35 m
Width:	1.76 m
Ground Clearance:	0.2 m
Platform Length - Stowed:	2.44 m
Platform Length - Extended (Deck out):	3.96 m
Platform Width (Inside):	1.42 m
Lift Capacity:	454 kg
Deck Extension:	1.52 m
Turning Radius Outside:	3.96 m
Turning Radius Inside:	1.52 m
Tyres:	Rough Terrain Rubber
Gradeability:	40 %
Power Source:	Diesel
Weight:	3,781 kg
Maximum Number of People:	4+ tools

CODE: 350185

MACHINE HAS 4X4
SELF LEVELLING JACK LEGS

HIRE RATES

Code	1 day	+1 day	1 week	4 weeks
350185	£175.00	£60.00	£295.00	£236.00*

Long term hire rates must be agreed at the time of hire *price per week



32' ROUGH TERRAIN 4X4 ELECTRIC SCISSOR LIFT

TECHNICAL SPECIFICATION

	Metric
Working Height:	11.75 m
Platform Height:	9.75 m
Height Stowed (Guardrails down):	1.75 m
Height Stowed (Guardrails up):	2.51 m
Length:	3.35 m
Width:	1.76 m
Ground Clearance:	0.2 m
Platform Length - Stowed:	2.44 m
Platform Length - Extended (Deck out):	3.96 m
Platform Width (Inside):	1.42 m
Lift Capacity:	454 kg
Deck Extension:	1.52 m
Turning Radius Outside:	3.96 m
Turning Radius Inside:	1.52 m
Tyres:	Non Marking Rough Terrain
Gradeability:	45 %
Power Source:	Battery
Weight:	3,844 kg
Maximum Number of People:	4+ tools

CODE: 350186

MACHINE HAS 4X4
SELF LEVELLING JACK LEGS

HIRE RATES

Code	1 day	+1 day	1 week	4 weeks
350186	£175.00	£60.00	£295.00	£236.00*

Long term hire rates must be agreed at the time of hire *price per week



WARNING - EQUIPMENT SPECIFICATION MAY VARY SLIGHTLY. IF IN DOUBT PLEASE PHONE TO CHECK.

All prices shown exclude VAT. Long term rates must be agreed at time of hire.

50' ROUGH TERRAIN 4X4 DIESEL SCISSOR LIFT



SCISSOR LIFTS

TECHNICAL SPECIFICATION

	Metric
Working Height:	17.24 m
Platform Height:	15.24 m
Height Stowed (Guardrails down):	2.29 m
Height Stowed (Guardrails up):	3.17 m
Length:	4.47 m
Width:	2.34 m
Ground Clearance:	20 cm
Platform Length - Stowed:	4.27 m
Platform Length - Extended (Deck out):	7.31 m
Platform Width (Inside):	1.88 m
Lift Capacity:	680 kg
Deck Extension (Each end)	1.52 m
Turning Radius Outside:	7.65 m
Turning Radius Inside:	5.33 m
Tyres:	Rough Terrain Rubber
Gradeability:	30 %
Power Source:	Diesel
Weight:	6,895 kg
Maximum Number of People:	5+ tools

CODE: 350190

MACHINE HAS 4X4
SELF LEVELLING JACK LEGS

HIRE RATES

Code	1 day	+1 day	1 week	4 weeks
350190	£220.00	£80.00	£380.00	£304.00*

Long term hire rates must be agreed at the time of hire *price per week



WARNING - EQUIPMENT SPECIFICATION MAY VARY SLIGHTLY. IF IN DOUBT PLEASE PHONE TO CHECK.
All prices shown exclude VAT. Long term rates must be agreed at time of hire.

IPAF TRAINING

for Scissor Lifts and Cherry Pickers

- Operator
- Mewps for Managers
- Demonstrator
- IPAF Harness
- PAL+
- Load/Unload
- For further information or to book call 01702 561818



www.mark1training.co.uk

MARKONE
HIRE

RUNABOUT GR15/GR20

TECHNICAL SPECIFICATION

	Metric
Working Height: GR15	6.35 m
Working Height: GR20	7.85 m
Platform Height: GR15	4.52 m
Platform Height: GR20	6.02 m
Platform Dimensions (Length x Width):	
Standard	0.94 x 0.75 m
Standard (with extension)	1.45 x 0.75 m
Height Stowed: GR15	1.57 m
Height Stowed: GR20	1.98 m
Length Stowed:	1.35 m
Width: GR15	75 cm
Width: GR20	80 cm
Lift Capacity: GR15	227 kg
Lift Capacity: GR20	159 kg
Ground Clearance:	6 cm
Turning Radius Outside:	1.42 m
Turning Radius Inside:	zero
Power Source:	Battery
Tyres:	Solid Non-marking Rubber
Gradeability:	30%
Weight: GR15	994 kg
Weight: GR20	1,112 kg
Maximum Number of People:	1+ tools

CODE: 350165 (GR15) / 350155 (GR20)

FOR INTERNAL USE ONLY
SOLID FLAT SURFACE ONLY

HIRE RATES

Code	1 day	+1 day	1 week	4 weeks
350165 (GR15)	£85.00	£45.00	£175.00	£140.00*
350155 (GR20)	£90.00	£45.00	£180.00	£144.00*

Long term hire rates must be agreed at the time of hire *price per week



STAR 10

TECHNICAL SPECIFICATION

	Metric
Working Height:	10 m
Platform Height:	8 m
Height Stowed:	1.99m
Working Outreach:	3 m
Length:	2.7 m
Width:	1 m
Wheelbase:	1.2 m
Ground Clearance:	10 cm
Platform Length - Stowed (Inside):	0.78 m
Platform Width (Inside):	0.99 m
Lift Capacity:	200 kg
Turning Radius Outside:	1.88 m
Power Source:	Battery
Tyres:	Solid Non-marking Rubber
Gradeability:	25%
Weight:	2,735 kg
Maximum Number of People:	2+ tools

CODE: 350175

FOR INTERNAL & EXTERNAL USE
SOLID FLAT SURFACE ONLY

HIRE RATES

Code	1 day	+1 day	1 week	4 weeks
350175	£140.00	£70.00	£280.00	£224.00*

Long term hire rates must be agreed at the time of hire *price per week



WARNING - EQUIPMENT SPECIFICATION MAY VARY SLIGHTLY. IF IN DOUBT PLEASE PHONE TO CHECK.

All prices shown exclude VAT. Long term rates must be agreed at time of hire.





POWER TOWER NANO SP

TECHNICAL SPECIFICATION

	Metric
Working Height:	4.5 m
Platform Height:	2.5 m
Height Stowed (Guardrails):	1.59 m
Length:	1.2 m
Width:	0.75 m
Ground Clearance:	50 mm
Platform Length - Stowed (Inside):	1.0 m
Platform Length - Extended (Inside):	1.5 m
Platform Width (Inside):	0.73 m
Lift Capacity:	200 kg
Deck Extension:	0.5 m
Power Source:	Battery
Weight:	478 kg
Maximum Number of People:	1+ tools

CODE: 350154

FOR INTERNAL USE ONLY
SOLID FLAT SURFACE ONLY

HIRE RATES

Code	1 day	+1 day	1 week	4 weeks
350154	£80.00	£20.00	£120.00	£96.00*

Long term hire rates must be agreed at the time of hire *price per week



POWER TOWER PUSH AROUND VERTICAL

TECHNICAL SPECIFICATION

	Metric
Working Height:	5.10 m
Platform Height:	3.10 m
Height Stowed (Guardrails):	1.85 m
Length:	1.6 m
Width:	0.78 m
Platform Length - Stowed (Inside):	1.52 m
Platform Width (Inside):	0.78 m
Lift Capacity:	250 kg
Power Source:	Battery
Tyres:	Solid Non-marking Rubber
Weight:	342 kg
Maximum Number of People:	1+ tools

CODE: 350153

FOR INTERNAL USE ONLY
SOLID FLAT SURFACE ONLY

HIRE RATES

Code	1 day	+1 day	1 week	4 weeks
350153	£69.00	£15.00	£99.00	£79.00*

Long term hire rates must be agreed at the time of hire *price per week



WARNING - EQUIPMENT SPECIFICATION MAY VARY SLIGHTLY. IF IN DOUBT PLEASE PHONE TO CHECK.

All prices shown exclude VAT. Long term rates must be agreed at time of hire.

AWP-25S GENIE PERSONNEL LIFT

TECHNICAL SPECIFICATION

	Metric
Working Height:	9.57 m
Platform Height:	7.57 m
Height Stowed:	1.98 m
Length:	1.31 m
Width:	0.74 m
Outrigger footprint:	1.75 x 1.55 m
Platform Length:	0.69 m
Platform Width:	0.66 m
Platform Height:	1.14 m
Power Source:	Battery
Weight:	371 kg
Lift Capacity:	159 kg
Maximum Number of People:	1+ tools

CODE: 350150

FOR INTERNAL USE ONLY
ADJUSTABLE LEVELLING OUTRIGGERS

HIRE RATES

Code	1 day	+1 day	1 week	4 weeks
350150	£85.00	£45.00	£175.00	£140.00*

Long term hire rates must be agreed at the time of hire *price per week



AWP-30S GENIE PERSONNEL LIFT

TECHNICAL SPECIFICATION

	Metric
Working Height:	11 m
Platform Height:	9 m
Height Stowed:	1.98 m
Length:	1.35 m
Width:	0.74 m
Outrigger footprint:	1.93 x 1.73 m
Platform Length:	0.69 m
Platform Width:	0.66 m
Platform Height:	1.14 m
Power Source:	Battery
Weight:	393 kg
Lift Capacity:	159 kg
Maximum Number of People:	1+ tools

CODE: 350151

FOR INTERNAL USE ONLY
ADJUSTABLE LEVELLING OUTRIGGERS

HIRE RATES

Code	1 day	+1 day	1 week	4 weeks
350151	£95.00	£50.00	£195.00	£156.00*

Long term hire rates must be agreed at the time of hire *price per week



WARNING - EQUIPMENT SPECIFICATION MAY VARY SLIGHTLY. IF IN DOUBT PLEASE PHONE TO CHECK.

All prices shown exclude VAT. Long term rates must be agreed at time of hire.





BOOM LIFTS

If your planned work requires any degree of outreach then Articulated Boom Lifts can perform an incredible range of tasks.



BENEFITS

- Outreach capabilities allowing you to overcome obstacles
- Fully proportional hydraulic controls - gets the user elevated rapidly, whilst feathering the controls allows precision positioning of the platform
- Telescopic upper boom for precise positioning
- Bi-Energy – petrol/diesel and battery maximises productivity and provides less down time
- Various machines with hydraulic legs for fast setup on uneven ground

SAFETY FEATURES

- Audible platform overload alarm
- Emergency stop switch at both platform and ground controls
- Heavy duty guardrails
- Built in lanyard attachment point
- Solid deck with slip-resistant surface
- Emergency descent lowering valve

WHEN HIRING YOU WILL BE PROVIDED WITH:

- A Certificate of Thorough Examination (LOLER)
- Operators Instruction Manual

Plus documented Handover Familiarisation to ensure you fully understand:

- Basic functions of the unit
- Pre-operational safety checks and maintenance
- Setting up procedure
- Site conditions and safety

Please note that Handover Familiarisation is not a replacement for training in the correct use of powered access equipment.

TRACKED NIFTY TD120T NARROW

SELF DRIVE NIFTY SD120TBE 4X4



TECHNICAL SPECIFICATION

	Metric
Working Height:	12.2 m
Platform Floor Height:	10.2 m
Height Stowed:	1.9 m
Working Outreach:	6.1 m
Length:	3.95 m
Width [with tracks in]:	0.75 m
Width [with stabilizers deployed]:	3 m
Platform Width:	0.75 m
Lift Capacity:	120 kg
Power Source:	Diesel/Mains 110V
Tyres:	Tracked
Gradeability:	60%
Weight:	1,850 kg
Maximum Number of People:	1+ tools

TECHNICAL SPECIFICATION

	Metric
Working Height:	12.65 m
Platform Floor Height:	10.65 m
Height Stowed:	1.95 m
Working Outreach:	6.1 m
Length:	3.9 m
Width [with stabilizers deployed]:	1.56 m
Platform Length:	0.65 m
Platform Width:	1.1 m
Lift Capacity:	200 kg
Turning Radius Outside:	3.9 m
Power Source:	Diesel/Battery
Gradeability:	45 %
Weight:	2,260 kg
Maximum Number of People:	2+ tools

CODE: 350086

CODE: 350080

FOR INTERNAL & EXTERNAL USE
ADJUSTABLE LEVELLING LEGS

FOR INTERNAL & EXTERNAL USE
ADJUSTABLE LEVELLING LEGS

HIRE RATES

Code	1 day	+1 day	1 week	4 weeks
350086	£220.00	£115.00	£450.00	£360.00*

HIRE RATES

Code	1 day	+1 day	1 week	4 weeks
350080	£195.00	£90.00	£375.00	£300.00*

Long term hire rates must be agreed at the time of hire *price per week

Long term hire rates must be agreed at the time of hire *price per week

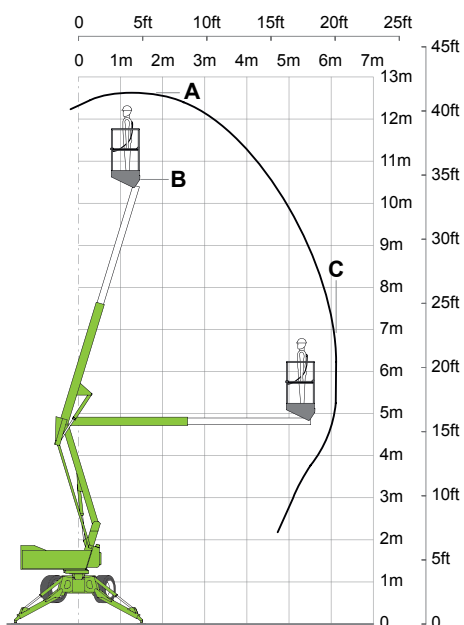
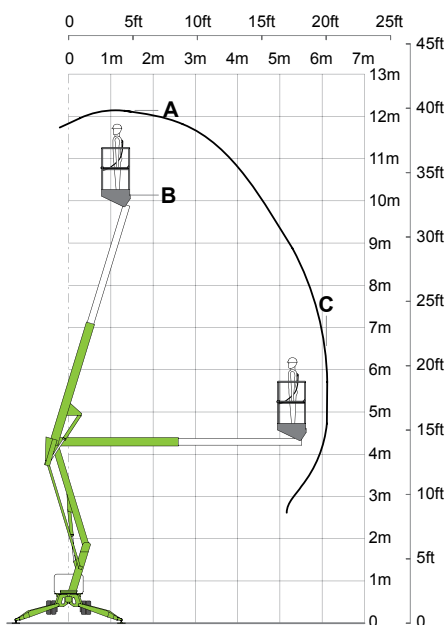

WARNING - EQUIPMENT SPECIFICATION MAY VARY SLIGHTLY. IF IN DOUBT PLEASE PHONE TO CHECK.

All prices shown exclude VAT. Long term rates must be agreed at time of hire.



SELF PROPELLED HR12NBE

TECHNICAL SPECIFICATION

	Metric
Working Height:	12.20 m
Platform Height:	10.20 m
Working Outreach:	6.10 m
Width:	1.50 m
Height Stowed:	1.90 m
Overall Length:	4.10 m
Weight:	3,170 kg
Turning Radius Outside:	4.20 m
Platform Capacity:	200 kg
Platform Size:	1.10 x 0.65 m
Power Source:	Bi-Energy (Diesel Engine & Battery)
Gradeability:	25 %
Maximum Number of People:	2+ tools

CODE: 350075

FOR INTERNAL & EXTERNAL USE
SOLID FLAT SURFACE ONLY

HIRE RATES

Code	1 day	+1 day	1 week	4 weeks
350075	£185.00	£70.00	£325.00	£260.00*

Long term hire rates must be agreed at the time of hire *price per week

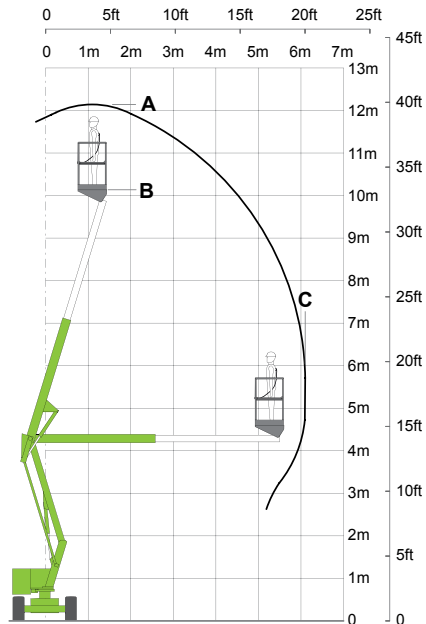

SELF PROPELLED Z45/25J BI-ENERGY

TECHNICAL SPECIFICATION

	Metric
Working Height:	15.94 m
Platform Height:	13.94 m
Working Outreach:	7.62 m
Width:	1.79 m
Height Stowed:	1.99 m
Length Stowed:	6.85 m
Weight:	7,620 kg
Turning Radius Outside:	4.27 m
Platform Capacity:	227 kg
Platform Size:	1.83 x 0.76 m
Power Source:	Bi-Energy (Diesel Engine & Battery)
Gradeability:	30 %
Maximum Number of People:	2+ tools

CODE: 350140

FOR INTERNAL & EXTERNAL USE
SOLID FLAT SURFACE ONLY

HIRE RATES

Code	1 day	+1 day	1 week	4 weeks
350140	£225.00	£100.00	£425.00	£340.00*

Long term hire rates must be agreed at the time of hire *price per week

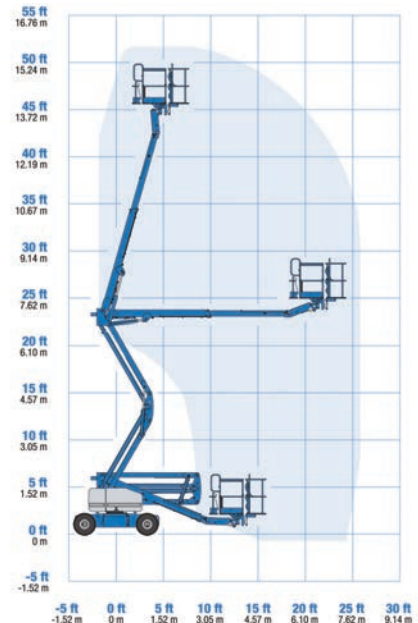

WARNING - EQUIPMENT SPECIFICATION MAY VARY SLIGHTLY. IF IN DOUBT PLEASE PHONE TO CHECK.

All prices shown exclude VAT. Long term rates must be agreed at time of hire.

SELF PROPELLED HR17 HYBRID 4X4

TECHNICAL SPECIFICATION

	Metric
Working Height:	17 m
Platform Height:	15 m
Working Outreach:	9.3 m
Width:	2 m
Height Stowed:	2.15 m
Length Stowed:	5 m
Overall Length:	6.3 m
Weight:	4,750 kg
Turning Radius Outside:	3.7 m
Platform Capacity:	225 kg
Platform Size:	1.8 x 0.85 m
Power Source:	Hybrid (Diesel Engine & Battery)
Gradeability:	40%
Maximum Number of People:	2+ tools

CODE: 350090

FOR INTERNAL & EXTERNAL USE
SOLID FLAT SURFACE ONLY

HIRE RATES

Code	1 day	+1 day	1 week	4 weeks
350090	£275.00	£100.00	£475.00	£380.00*

Long term hire rates must be agreed at the time of hire *price per week

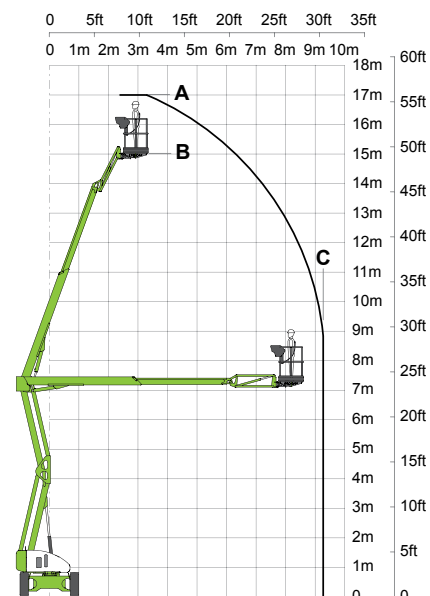

SELF PROPELLED HR17 NARROW HYBRID

TECHNICAL SPECIFICATION

	Metric
Working Height:	17 m
Platform Height:	15 m
Working Outreach:	9.7 m
Width:	1.5 m
Height Stowed:	1.99 m
Length Stowed:	4.93 m
Overall Length:	6.4 m
Weight:	7,650 kg
Turning Radius Outside:	3.5 m
Platform Capacity:	225 kg
Platform Size:	1.5 x 0.8 m
Power Source:	Hybrid (Diesel Engine & Battery)
Gradeability:	25%
Maximum Number of People:	2+ tools

CODE: 350095

FOR INTERNAL & EXTERNAL USE
SOLID FLAT SURFACE ONLY

HIRE RATES

Code	1 day	+1 day	1 week	4 weeks
350095	£275.00	£100.00	£475.00	£380.00*

Long term hire rates must be agreed at the time of hire *price per week

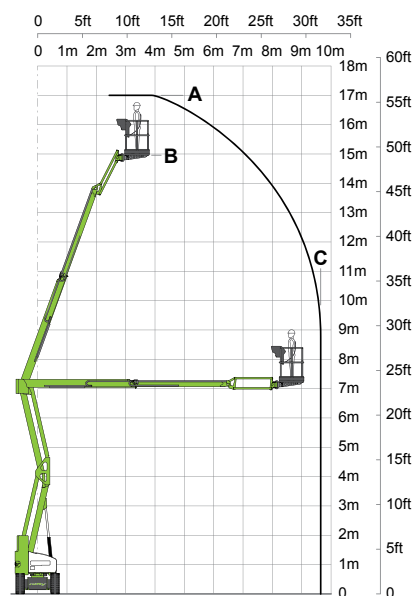

WARNING - EQUIPMENT SPECIFICATION MAY VARY SLIGHTLY. IF IN DOUBT PLEASE PHONE TO CHECK.

All prices shown exclude VAT. Long term rates must be agreed at time of hire.





SELF PROPELLED HR21 HYBRID 4X4

TECHNICAL SPECIFICATION

	Metric
Working Height:	21 m
Platform Height:	19 m
Working Outreach:	12.8 m
Width:	2.27 m
Height Stowed:	2.15 m
Length Stowed:	5.3 m
Overall Length:	6.7 m
Weight:	6,500 kg
Turning Radius Outside:	4 m
Platform Capacity:	225 kg
Platform Size:	1.8 x 0.85 m
Power Source:	Hybrid (Diesel Engine & Battery)
Gradeability:	40%
Maximum Number of People:	2+ tools

CODE: 350145

FOR INTERNAL & EXTERNAL USE
SOLID FLAT SURFACE ONLY

HIRE RATES

Code	1 day	+1 day	1 week	4 weeks
350145	£395.00	£100.00	£595.00	£476.00*

Long term hire rates must be agreed at the time of hire *price per week

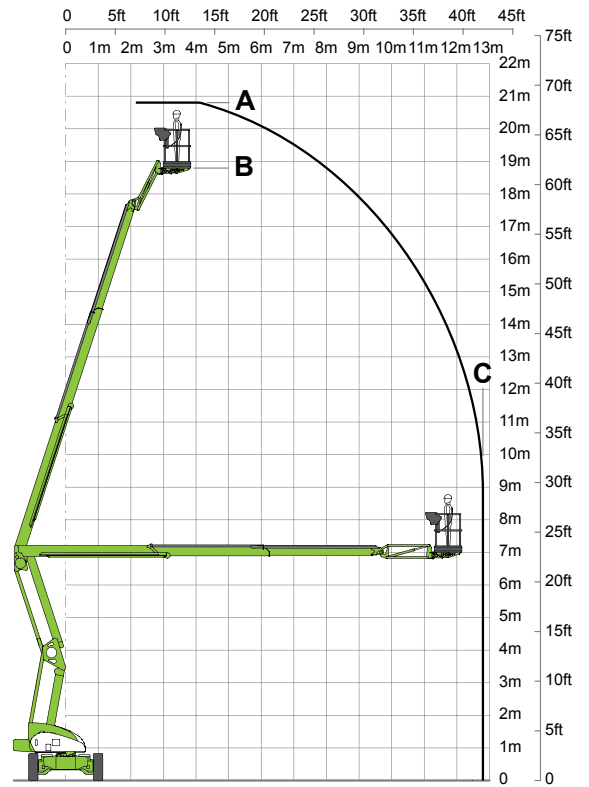

WARNING - EQUIPMENT SPECIFICATION MAY VARY SLIGHTLY. IF IN DOUBT PLEASE PHONE TO CHECK.

All prices shown exclude VAT. Long term rates must be agreed at time of hire.

NEW

CLIMAX BASIC PLUS HARNESS

WITH 2 X KARABINERS & 1M LANYARD



FOR SALE
£22.50 +VAT

MARKONE

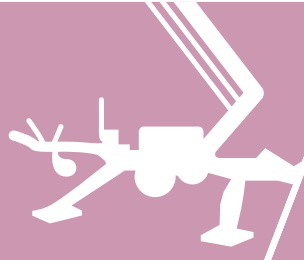

TOWABLE BOOM LIFTS

These machines are road towable and can be transported easily from site to site and set up quickly using built in hydraulic outriggers. They are light and compact and offer an excellent working envelope.

BENEFITS

- Outreach capabilities allowing you to overcome obstacles
- Fully proportional hydraulic controls - gets the user elevated rapidly, whilst feathering the controls allows precision positioning of the platform
- Telescopic upper boom for precise positioning
- Bi-Energy – petrol/diesel and battery maximises productivity and provides less down time
- Various machines with hydraulic legs for fast setup on uneven ground.

SAFETY FEATURES

- Audible platform overload alarm
- Emergency stop switch at both platform and ground controls
- Heavy duty guardrails
- Built in lanyard attachment point
- Solid deck with slip-resistant surface
- Emergency descent lowering valve

WHEN HIRING YOU WILL BE PROVIDED WITH:

- A Certificate of Thorough Examination (LOLER)
- Operators Instruction Manual

Plus documented Handover Familiarisation to ensure you fully understand:

- Basic functions of the unit
- Pre-operational safety checks and maintenance
- Setting up procedure
- Site conditions and safety

Please note that Handover Familiarisation is not a replacement for training in the correct use of powered access equipment.



TOWABLE BOOM LIFT NIFTY 120TB

TECHNICAL SPECIFICATION

	Metric
Working Height:	12.20 m
Platform Height:	10.20 m
Working Outreach:	6.10 m
Slew:	360°
Travelling Width:	1.50 m
Working Width (Legs deployed):	3.55 m
Axels Retracted Width:	1.10 m
Height Stowed:	1.90 m
Overall Length:	4.50 m
Weight:	1,400 kg
Platform Capacity:	200 kg
Platform Size:	1.10 x 0.65 m
Power Source:	Bi-Energy (Petrol & Battery)
Wind Speed:	12.5 m/s
Maximum Number of People:	2+ tools

CODE: 350060

ADJUSTABLE LEVELLING LEGS

HIRE RATES

Code	1 day	+1 day	1 week	4 weeks
350060	£120.00	£115.00	£350.00	£280.00*

Long term hire rates must be agreed at the time of hire *price per week

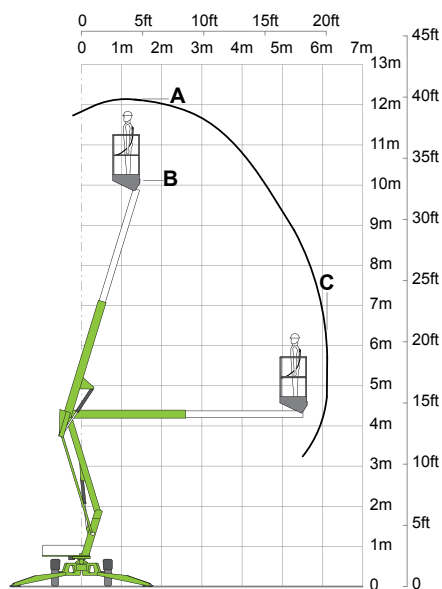

TOWABLE BOOM LIFT NIFTY 150TB

TECHNICAL SPECIFICATION

	Metric
Working Height:	14.70 m
Platform Height:	12.70 m
Working Outreach:	7.55 m
Slew:	400°
Travelling Width:	1.60 m
Working Width (Legs deployed):	3.80 m
Overall Height:	2.00 m
Overall Length:	5.55 m
Weight:	1,800 kg
Platform Capacity:	225 kg
Platform Size:	1.40 x 0.70 m
Power Source:	Bi-Energy (Petrol & Battery)
Wind Speed:	12.5 m/s
Maximum Number of People:	2+ tools

CODE: 350065

ADJUSTABLE LEVELLING LEGS

HIRE RATES

Code	1 day	+1 day	1 week	4 weeks
350065	£150.00	£112.50	£375.00	£300.00*

Long term hire rates must be agreed at the time of hire *price per week

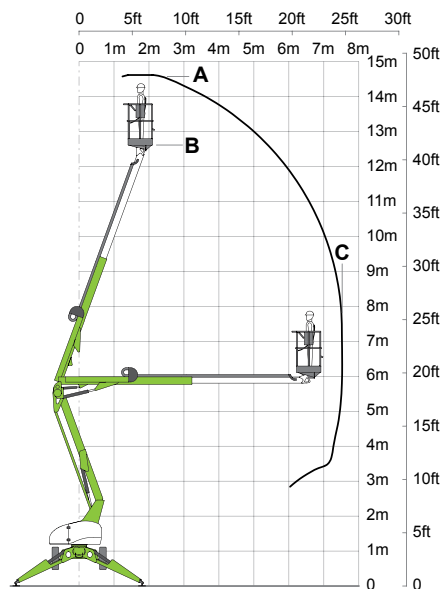

WARNING - EQUIPMENT SPECIFICATION MAY VARY SLIGHTLY. IF IN DOUBT PLEASE PHONE TO CHECK.

All prices shown exclude VAT. Long term rates must be agreed at time of hire.





TOWABLE BOOM LIFT NIFTY 170BE

TECHNICAL SPECIFICATION

	Metric
Working Height:	17.10 m
Platform Height:	15.10 m
Working Outreach:	8.70 m
Slew:	360°
Travelling Width:	1.72 m
Working Width (Legs deployed):	4.40 m
Overall Height:	2.15 m
Overall Length:	6.20 m
Weight:	2,220 kg
Platform Capacity:	200 kg
Platform Size:	1.10 x 0.65 m
Power Source:	Bi-Energy (Diesel Engine & Battery)
Wind Speed:	12.5 m/s
Maximum Number of People	2+ tools

CODE: 350070

ADJUSTABLE LEVELLING LEGS

HIRE RATES

Code	1 day	+1 day	1 week	4 weeks
350070	£170.00	£127.50	£425.00	£340.00*

Long term hire rates must be agreed at the time of hire *price per week

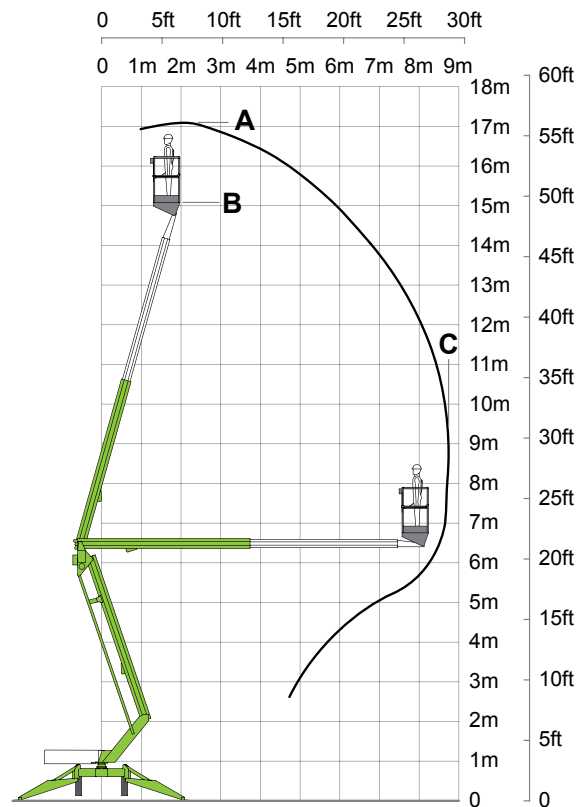

WARNING

EQUIPMENT SPECIFICATION MAY VARY SLIGHTLY. IF IN DOUBT PLEASE PHONE TO CHECK.

TOWABLES ARE LOCATED AT OUR SOUTHEND, CHELMSFORD & RAYLEIGH DEPOTS. THEY ARE READY FOR COLLECTION OR DELIVERY, PLEASE CONTACT US FOR MORE INFORMATION

WARNING - EQUIPMENT SPECIFICATION MAY VARY SLIGHTLY. IF IN DOUBT PLEASE PHONE TO CHECK.
All prices shown exclude VAT. Long term rates must be agreed at time of hire.

BoSS ALUMINIUM TOWERS 6' X 5' (1800MM X 1450MM)

Our range of access towers all comply with Health & Safety Executive's recommended assembly methods 3T (Through the Trap) and the advanced guardrail system. The 3T method requires that the operator takes up a position of minimum risk within the trap; from this position guard rail components are added or removed on the level above.

HIRE RATES					
Code	Height	1 day	+1 day	1 week	4 weeks
BOSS1.2	1.2m/3'11"	£35.00	£5.00	£45.00	£36.00*
BOSS2.2	1.2m/3'11"	£43.00	£6.00	£55.00	£44.00*
BOSS3.2	3.2m/10'8"	£52.00	£6.50	£65.00	£52.00*
BOSS4.2	4.2m/13'10"	£68.00	£7.00	£82.00	£65.50*
BOSS5.2	5.2m/17'1"	£75.00	£10.00	£95.00	£76.00*
BOSS5.2	6.2m/20'4"	£89.00	£10.50	£110.00	£88.00*
BOSS7.2	7.2m/23'7"	£105.00	£12.00	£129.00	£103.00*
BOSS8.2	8.2m/26'11"	£120.00	£12.50	£145.00	£116.00*
BOSS9.2	9.2m/30'3"	£130.00	£12.50	£155.00	£124.00*
BOSS10.2	10.2m/33'6"	£135.00	£17.50	£170.00	£136.00*
BOSS11.2	11.2m/36'9"	£140.00	£22.50	£185.00	£148.00*
BOSS12.2	12.2m/40'	£150.00	£25.00	£200.00	£160.00*

Heights specified are platform height, not working height *price per week



BoSS ALUMINIUM NARROW TOWERS 6FT X 3FT (1800MM X 910MM)

IMPORTANT

External towers above 8.2m and internal towers above 11.2m must be tied in to a rigid structure in accordance with the tower instruction manual.

HIRE RATES					
Code	Height	1 day	+1 day	1 week	4 weeks
NARROW1.2	1.2m/3'11"	£35.00	£5.00	£45.00	£36.00*
NARROW2.2	2.2m/7'2"	£43.00	£6.00	£55.00	£44.00*
NARROW3.2	3.2m/10'8"	£52.00	£6.50	£65.00	£52.00*
NARROW4.2	4.2m/13'10"	£68.00	£7.00	£82.00	£65.50*
NARROW5.2	5.2m/17'1"	£75.00	£10.00	£95.00	£76.00*
NARROW6.2	6.2m/20'4"	£89.00	£10.50	£110.00	£88.00*
NARROW7.2	7.2m/23'7"	£105.00	£12.00	£129.00	£103.00*
NARROW8.2	8.2m/26'11"	£120.00	£12.50	£145.00	£116.00*
NARROW9.2	9.2m/30'3"	£130.00	£12.50	£155.00	£124.00*
NARROW10.2	10.2m/33'6"	£135.00	£17.50	£170.00	£136.00*
NARROW11.2	11.2m/36'9"	£140.00	£22.50	£185.00	£148.00*
NARROW12.2	12.2m/40'	£150.00	£25.00	£200.00	£160.00*

Heights specified are platform height, not working height *price per week



WARNING - EQUIPMENT SPECIFICATION MAY VARY SLIGHTLY. IF IN DOUBT PLEASE PHONE TO CHECK.

All prices shown exclude VAT. Long term rates must be agreed at time of hire.





AGR BoSS ALUMINIUM TOWERS (ADVANCED GUARD RAIL) 6FT X 5FT (1800MM X 1450MM)

The BoSS Cam-lock Advance Guardrail provides an alternative build method and offers benefits such as: safer assembly, extra tower rigidity, fewer components and clear identifiable locking mechanisms.

HIRE RATES					
Code	Height	1 day	+1 day	1 week	4 weeks
BOSS2.2A	2.2m/7'2"	£43.00	£6.00	£55.00	£44.00*
BOSS2.7A	2.7m/8'10"	£51.00	£6.50	£64.00	£51.00*
BOSS3.7A	3.7m/12'1"	£59.00	£7.00	£73.00	£58.00*
BOSS4.2A	4.2m/13'10"	£68.00	£7.00	£82.00	£65.50*
BOSS4.7A	4.7m/15'5"	£75.00	£8.00	£91.00	£73.00*
BOSS5.7A	5.7m/18'8"	£82.00	£9.00	£100.00	£80.00*
BOSS6.2A	6.2m/20'4"	£89.00	£10.50	£110.00	£88.00*
BOSS6.7A	6.7m/22'	£99.00	£11.00	£121.00	£97.00*
BOSS7.7A	7.7m/25'3"	£109.00	£11.50	£132.00	£105.50*
BOSS8.2A	8.2m/26'11"	£120.00	£12.50	£145.00	£116.00*
BOSS8.7A	8.7m/28'6"	£125.00	£14.00	£153.00	£122.50*
BOSS9.7A	9.7m/31'10"	£130.00	£15.50	£161.00	£129.00*
BOSS10.2A	10.2m/33'5"	£135.00	£17.50	£170.00	£136.00*
BOSS10.7A	10.7m/35'1"	£140.00	£20.00	£180.00	£144.00*
BOSS11.7A	11.7m/38'4"	£145.00	£22.50	£190.00	£152.00*
BOSS12.2A	12.2m/40'	£150.00	£25.00	£200.00	£160.00*

Heights specified are platform height, not working height *price per week

AGR BoSS NARROW ALUMINIUM TOWERS (ADVANCED GUARD RAIL) 6FT X 3FT (1800MM X 910MM)

HIRE RATES					
Code	Height	1 day	+1 day	1 week	4 weeks
BOSS2.2A	2.2m/7'2"	£43.00	£6.00	£55.00	£44.00*
BOSS2.7A	2.7m/8'10"	£51.00	£6.50	£64.00	£51.00*
BOSS3.7A	3.7m/12'1"	£59.00	£7.00	£73.00	£58.00*
BOSS4.2A	4.2m/13'10"	£68.00	£7.00	£82.00	£65.50*
BOSS4.7A	4.7m/15'5"	£75.00	£8.00	£91.00	£73.00*
BOSS5.7A	5.7m/18'8"	£82.00	£9.00	£100.00	£80.00*
BOSS6.2A	6.2m/20'4"	£89.00	£10.50	£110.00	£88.00*
BOSS6.7A	6.7m/22'	£99.00	£11.00	£121.00	£97.00*
BOSS7.7A	7.7m/25'3"	£109.00	£11.50	£132.00	£105.50*
BOSS8.2A	8.2m/26'11"	£120.00	£12.50	£145.00	£116.00*
BOSS8.7A	8.7m/28'6"	£125.00	£14.00	£153.00	£122.50*
BOSS9.7A	9.7m/31'10"	£130.00	£15.50	£161.00	£129.00*
BOSS10.2A	10.2m/33'5"	£135.00	£17.50	£170.00	£136.00*
BOSS10.7A	10.7m/35'1"	£140.00	£20.00	£180.00	£144.00*
BOSS11.7A	11.7m/38'4"	£145.00	£22.50	£190.00	£152.00*
BOSS12.2A	12.2m/40'	£150.00	£25.00	£200.00	£160.00*

Heights specified are platform height, not working height *price per week



WARNING - EQUIPMENT SPECIFICATION MAY VARY SLIGHTLY. IF IN DOUBT PLEASE PHONE TO CHECK.

All prices shown exclude VAT. Long term rates must be agreed at time of hire.

GRP ZONE 1 TOWERS 6' X 5' (1800MM X 1450MM)

This fibreglass industrial access tower system is specifically designed to be non-conductive/sparking, non-corroding and non-oxidising. It has ribbed rung tubing for increased grip and follows the 3T assembly method (Through the trap)

HIRE RATES			
Code	Height	1 week	4 weeks
GRPL1.2	1.2m/3'11"	£100.00	£80.00*
GRPL2.2	2.2m/7'2"	£110.00	£88.00*
GRPL3.2	3.2m/10'6"	£125.00	£100.00*
GRPL4.2	4.2m/13'10"	£135.00	£108.00*
GRPL5.2	5.2m/17'1"	£145.00	£116.00*
GRPL6.2	6.2m/20'4"	£170.00	£136.00*
GRPL7.2	7.2m/23'7"	£195.00	£156.00*
GRPL8.2	8.2m/26'11"	£225.00	£180.00*
GRPL9.2	9.2m/30'3"	£240.00	£192.00*
GRPL10.2	10.2m/33'6"	£275.00	£220.00*
GRPL11.2	11.2m/39'9"	£300.00	£240.00*
GRPL12.2	12.2m/40'	£325.00	£260.00*

Heights specified are platform height, not working height *price per week

GRP ZONE 1 NARROW TOWERS 6' X 3' (180MM X 910MM)

HIRE RATES			
Code	Height	1 week	4 weeks
GRPL1.2	1.2m/3'11"	£100.00	£80.00*
GRPL2.2	2.2m/7'2"	£110.00	£88.00*
GRPL3.2	3.2m/10'6"	£125.00	£100.00*
GRPL4.2	4.2m/13'10"	£135.00	£108.00*
GRPL5.2	5.2m/17'1"	£145.00	£116.00*
GRPL6.2	6.2m/20'4"	£170.00	£136.00*
GRPL7.2	7.2m/23'7"	£195.00	£156.00*
*** INTERNAL USE ONLY***			
GRPL8.2	8.2m/26'11"	£225.00	£180.00*
GRPL9.2	9.2m/30'3"	£240.00	£192.00*
GRPL10.2	10.2m/33'6"	£275.00	£220.00*
GRPL11.2	11.2m/39'9"	£300.00	£240.00*
GRPL12.2	12.2m/40'	£325.00	£260.00*

Heights specified are platform height, not working height *price per week



PASMA MOBILE ACCESS TOWER TRAINING

- £99 per person
- Open courses run at least twice a week
- On-site training available
- For further information or to book call 01702 561818



www.mark1training.co.uk

**MARKONE**
TRAINING
HIRE



CANTILEVER TOWERS

Manufactured to fit the standard BoSS 1.83m x 1.52m tower, these accessories allow a working platform over obstructions up to 850mm from the towers edge. Counter weights are used to stabilise the tower.



HIRE RATES

Code	Height	1 week	4 weeks
CANT2.2	2.2m / 7'2" (Complete)	£95.00	£76.00*
CANT3.2	3.2m / 10'8" (Complete)	£109.00	£87.00*
CANT4.2	4.2m / 13'10" (Complete)	£129.00	£103.00*
CANT5.2	5.2m / 17'1" (Complete)	£149.00	£119.00*
CANT6.2	6.2m / 20'4" (Complete)	£169.00	£135.00*

Heights specified are platform height, not working height *price per week

LIFT SHAFT TOWERS

This lightweight industrial aluminium lift shaft/confined space access tower is ideal for lift shaft installations, maintenance and servicing, or any confined space work where standard BoSS towers will not fit. Minimum area = 1350mm x 910mm



HIRE RATES

Code	Height	1 week	4 weeks
LIFT1.2	1.2m / 4'1"	£50.00	£40.00*
LIFT2.2	2.2m / 7'2"	£60.00	£48.00*
LIFT3.2	3.2m / 10'8"	£70.00	£56.00*
LIFT4.2	4.2m / 13'10"	£85.00	£68.00*
LIFT5.2	5.2m / 17'1"	£100.00	£80.00*
LIFT6.2	6.2m / 20'4"	£115.00	£92.00*
LIFT7.2	7.2m / 23'7"	£130.00	£104.00*
LIFT8.2	8.2m / 26'11"	£145.00	£116.00*
LIFT9.2	9.2m / 30'3"	£160.00	£128.00*
LIFT10.2	10.2m / 33'6"	£175.00	£140.00*

Heights specified are platform height, not working height *price per week

STAIRWELL TOWERS

Robustly constructed, yet easy to erect our range of Stairwell Towers allow users to work safely on commercial and domestic stairwells. Features include: narrow base adjustable legs and non-slip trappdoors. Access can be gained from either end of the stairwell unit via a walk through ladder frame.



HIRE RATES

Code	Height	1 week	4 weeks
STAIR2.8	2.8m	£57.00	£45.50*
STAIR4.3	4.3m	£72.00	£57.50*
STAIR5.8	5.8m	£95.00	£76.00*
STAIR7.3	7.3m	£109.00	£87.00*

Heights specified are platform height, not working height *price per week

MINIMAX FOLDING PLATFORMS

For indoor and outdoor use, the Minimax is the ideal lightweight and modular platform and tower system. Fitting through standard doorways and down corridors with snap click fittings and versatile stepped height platform adjustment, the Minimax is the ultimate one person system. The base pack will give you a platform height of 0.6m with a working height of 2.6m. Extension packs can be added for extra reach if required.

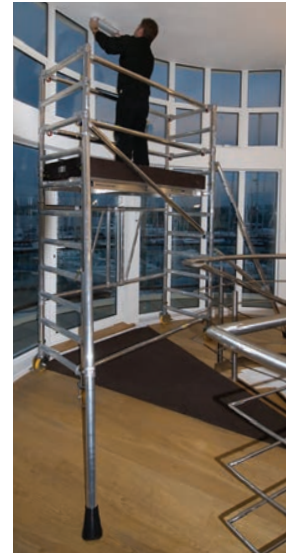

HIRE RATES

Code	Height	1 day	+1 day	1 week	4 weeks
010180	0.6m – SWH 2.60m	£35.00	£9.50	£49.00	£39.00*
MINIMAXGR	Mini Max 1m Extension Pack (Platform height 1.7m)	£13.00	£3.50	£20.00	£16.00*
MINIMAX2N	Mini Max 2m Extension Pack (Platform height 3.7m)	£25.00	£7.50	£40.00	£32.00*

Heights specified are platform height, not working height *price per week

WARNING - EQUIPMENT SPECIFICATION MAY VARY SLIGHTLY. IF IN DOUBT PLEASE PHONE TO CHECK.

All prices shown exclude VAT. Long term rates must be agreed at time of hire.



1.5M PODIUM STEPS

This unit has been designed to provide a safer way of working at low levels and offers six platform heights of: 250mm, 500mm, 750mm, 1m, 1.25m and 1.50m. Its 600mm² platform area offers an ideal working space for one man and tools. With a telescopic handrail section the correct guardrail height is achieved at each of the six levels to ensure user safety. The unit is fitted with anti-surf feet that prevent the user from moving the unit whilst standing on the platform. The podiums can be moved simply by lifting the fixed side and wheeling it along. When open or closed the unit will pass through doors and corridors with ease when extension pack is lowered.



HIRE RATES

Code	Height	1 day	+1 day	1 week	4 weeks
010172	1m to 1.5m	£32.00	£8.50	£49.00	£39.00*

Heights specified are platform height, not working height *price per week

ALUMINIUM STEPS

Our range of Step Ladders are certified for industrial use and are suitable for inspection work, access to work places and in accordance with the Working at Height regulations, light work of a short duration.



HIRE RATES

Code	Height	1 day	+1 day	1 week	4 weeks
010126	SWH 2.35m - OPEN 1.27m (6 TREAD)	£12.00	£3.50	£19.00	£15.00*
010128	SWH 2.56m - OPEN 1.69m (8 TREAD)	£14.00	£4.00	£22.00	£17.50*
010130	SWH 2.98m - OPEN 2.10m (10 TREAD)	£16.00	£4.50	£25.00	£20.00*
010132	SWH 3.39m - OPEN 2.52m (12 TREAD)	£18.00	£5.50	£29.00	£23.00*
010134	(14 TREAD)	£24.00	£9.00	£42.00	£33.50*

Heights specified are platform height, not working height *price per week

SHERPA TELESCOPIC STEPS

Fully enclosed step ladders with variable platform heights from 1770mm to 2230mm. Adjustable stabilisers are fitted for added stability. Folds down for easy storage and transportation.



HIRE RATES

Code	Height	1 day	+1 day	1 week	4 weeks
010192	1.06m to 1.53m (4 to 6 Tread)	£34.00	£14.00	£62.00	£49.50*

Heights specified are platform height, not working height *price per week

GRP STEPS

Glassfibre Reinforced Plastic (GRP) Step Ladders are non sparking and corrosion resistant, ideal for areas where there is a risk of fire or hazard from electrical or chemical contact. In addition they are suitable for use in 'clean' environments such as food and hi-tech manufacturing. They are suitable for inspection work, access to work places and in accordance with the Working at Height regulations, light work of a short duration.



HIRE RATES

Code	Height	1 day	+1 day	1 week	4 weeks
010152	SWH 2.60m - OPEN 1.65m (6 TREAD)	£14.00	£3.00	£20.00	£16.00*
010154	SWH 3.13m - OPEN 2.20m (8 TREAD)	£17.00	£4.00	£25.00	£20.00*
010156	(10 TREAD)	£19.00	£5.00	£29.00	£23.00*

Heights specified are platform height, not working height *price per week

WARNING - EQUIPMENT SPECIFICATION MAY VARY SLIGHTLY. IF IN DOUBT PLEASE PHONE TO CHECK.

All prices shown exclude VAT. Long term rates must be agreed at time of hire.



STAGING BOARDS & HANDRAILS

All Staging & Handrail Systems comply with the relevant BS2037 specifications. Staging boards are non-slip and able to support up to 270kg. When used in conjunction with the hand rail system they provide a safe means of working at height and are ideal for linking all towers.

HIRE RATES - STAGING BOARDS (450MM WIDE)					
Code	Height	1 day	+1 day	1 week	4 weeks
020108	8' (2.43m) (yellow)	£15.00	£2.00	£19.00	£15.00*
020110	10' (3.04m) (green)	£17.00	£2.00	£21.00	£16.75*
020112	12' (3.65m) (orange)	£19.00	£3.00	£25.00	£20.00*
020116	16' (4.87m) (green)	£22.00	£3.50	£29.00	£23.00*
020120	20' (6.00m) (red)	£25.00	£7.00	£39.00	£31.00*
020124	24' (7.31m) (black)	£34.00	£15.00	£64.00	£51.00*

*price per week



HIRE RATES - HANDRAILS				
Code	Description	1 week	4 weeks	
HANDRAIL8	Handrail System for 8' Staging Board	£13.50	£10.75*	
HANDRAIL10	Handrail System for 10' Staging Board	£15.00	£12.00*	
HANDRAIL12	Handrail System for 12' Staging Board	£25.00	£20.00*	
HANDRAIL16	Handrail System for 16' Staging Board	£27.00	£21.50*	
HANDRAIL20	Handrail System for 20' Staging Board	£29.00	£23.00*	
HANDRAIL24	Handrail System for 24' Staging Board	£40.00	£32.00*	

Prices listed only include one side of handrail

*price per week



DESKSPAN HIGH-CLEARANCE TOWERS

This unit is specifically designed to be used over non-movable objects such as desks, hedges, conveyers etc. This unit allows for a 1.5m height clearance, with a working platform of 2.5m x 0.7m and safe working load of 250kg. The use of AGR (advance guard rail) reduces the amount of components and time required to erect this work platform.

HIRE RATES - STAGING BOARDS (450MM WIDE)					
Code	Description	1 day	+1 day	1 week	4 weeks
010220	Deskspan high clearance tower	£45.00	£15.00	£75.00	£60.00*

Heights specified are platform height, not working height *price per week

WARNING - EQUIPMENT SPECIFICATION MAY VARY SLIGHTLY. IF IN DOUBT PLEASE PHONE TO CHECK.

All prices shown exclude VAT. Long term rates must be agreed at time of hire.

TRESTLES & SCAFFOLD BOARDS

Builder's trestles are certified to BS2037 class 1 and can incorporate a handrail and support system. Changes in the Working at Height legislation means that trestles should only be used for light work of short duration.

HIRE RATES - PAINTER TRESTLES					
Code	Height	1 day	+1 day	1 week	4 weeks
020170	6' Ali (1.83m)	£14.00	£4.00	£22.00	£17.50*
020180	8' Ali (2.44m)	£16.00	£4.50	£25.00	£20.00*
020190	10' Ali (3.05m)	£19.00	£5.50	£30.00	£24.00*

*price per week

HIRE RATES - STEEL TRESTLES (1000MM WIDE)				
Code	Description	1 week	4 weeks	
TRES1	1'7" EXT 2'5" Yellow 0.448m to 0.74m	£3.75	£3.00*	
TRES2	2'6" EXT 4' res 0.76m to 1.22m	£3.75	£3.00*	
TRES3	3'6" EXT 5'9" Green 1.07m to 1.75m	£3.75	£3.00*	
TRES4	4'6" EXT 7'2" Blue 1.37m to 2.18m	£3.75	£3.00*	

*price per week

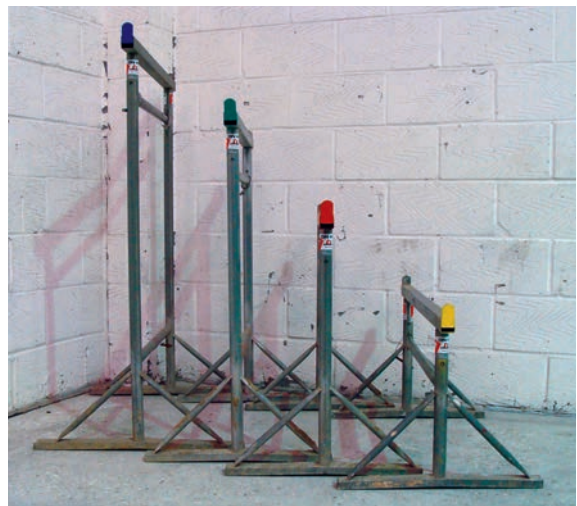

HIRE RATES - SCAFFOLD BOARDS (230MM WIDE)				
Code	Height	1 week	4 weeks	
SCAF8	8' 2.43m (blue)	£2.75	£2.00*	
SCAF10	10' 3.04m (yellow)	£2.75	£2.00*	
SCAF13	13' 3.96m (red)	£2.75	£2.00*	

*price per week

GRP DOUBLE 4.2 TO 7.5M (14FT) LADDERS

Double extending 4.2m rope operated GRP ladder giving a maximum safe working height of 7.8m. Non-conductive to 30,000 volts so ideal in areas where there is a risk of hazard from electrical or chemical contact. 14 slip resistant rungs per section giving the ladder a total weight of 23Kg.

HIRE RATES - STAGING BOARDS (450MM WIDE)					
Code	Description	1 day	+1 day	1 week	4 weeks
010060	GRP Double 4.2 Ladder	£35.00	£10.00	£55.00	£44.00*

Heights specified are platform height, not working height *price per week

CONSERVATORY LADDERS

Two part ladder specially designed for safe, easy access to conservatory roofs. Ideal for cleaning or general maintenance work in awkward to get at areas. The adjustable upper section allows for secure positioning on the pitch of the roof.



HIRE RATES

Code	Description	1 day	+1 day	1 week	4 weeks
010085	Conservatory access ladder	£35.00	£10.00	£55.00	£44.00*

*price per week

ALUMINIUM LADDERS

Our range of Aluminium Ladders are certified for industrial use and are suitable for inspection work, access to work places and in accordance with the Working at Height regulations, light work of a short duration.



SAFETY FIRST

Ladder stoppers and ladder stays are available on request.

HIRE RATES - STAGING BOARDS (450MM WIDE)

Code	Description	1 day	+1 day	1 week	4 weeks
010010	Ladder double 8' (SWH 14'15" 4.41m) Closed 8'2" 2.50m/open 13'9" 3.95m	£17.00	£5.50	£28.00	£22.25*
010030	Ladder double 14' (SWH 25'2" 7.68m) Closed 13'9" 4.24m/open 24'4" 7.43m	£18.00	£6.00	£30.00	£24.00*
010035	Ladder triple 8' (SWH 19'8" 6.04m) Closed 8'2" 2.50m/open 18'2" 5.56m	£21.00	£5.50	£32.00	£24.00*
010040	Ladder triple 14" (SWH 35' 10.68m) Closed 13'9" 4.24m/open 34'8" 10.62m	£25.00	£7.50	£40.00	£32.00*

*price per week

COMBI LADDERS

Three section aluminium ladder with the versatility to complete many different tasks. Quickly and simply adapts to each mode be it, step ladder, extension ladder, extending step ladder or stairway ladder.



HIRE RATES

Code	Height	1 day	+1 day	1 week	4 weeks
010070	7.02m ladder/ 3.75m steps	£25.00	£7.00	£39.00	£31.00*

*price per week

ROOF LADDERS

An aluminium ladder designed principally to reduce risk to the user. It uses a ridge hook to hold the ladder in position with support bearers to distribute weight evenly preventing damage to the roof. Two wheels fitted to the underside allow the ladder to be pushed up the roof without causing damage to slates or tiles. Designed for pitched roofs up to an angle of 55° the ladder is easily positioned and totally secure in use. Available to hire as either a 4.2m single ladder or as a double 6.6m extending one.



HIRE RATES

Code	Height	1 day	+1 day	1 week	4 weeks
010090	14' (4.24m)	£21.00	£4.00	£29.00	£23.00*
010110	12'9" (3.9m) to 21'9" (6.6m)	£24.00	£7.50	£39.00	£31.00*

*price per week

WARNING - EQUIPMENT SPECIFICATION MAY VARY SLIGHTLY. IF IN DOUBT PLEASE PHONE TO CHECK.

All prices shown exclude VAT. Long term rates must be agreed at time of hire.



IPAF TRAINING

We offer a full range of IPAF courses including; IPAF Operator, IPAF Demonstrator, IPAF PAV, IPAF Harness, IPAF Load/Unload, IPAF MEWPS for Manager and IPAF PAL+

THE IPAF OPERATOR COURSE

We offer training for anyone that operates Mobile Elevated Work Platforms (MEWPs), typically Scissor Lifts, Vertical Platforms, Cherry Pickers, Static or Self Propelled Telescopic and Articulating Booms.

MACHINE CATEGORIES



Category 3a Mobile Vertical

Scissor lifts, vertical personnel platforms (mobile)



Category 1b Static Boom

Self-propelled booms (outriggers), trailers/push-around, vehicle mounted platforms



Category 3b Mobile Boom

Self-propelled boom

- Courses run on a daily basis (Monday to Friday)
- Saturday training available (at an additional cost)
- Approved IPAF Training Centre
- On site training available (subject to certain requirements)
- Group discounts available
- Accredited by IPAF – IPAF card and certificate included, valid for 5 years
- Please visit our website or contact us for more details

PRICES

IPAF1	£150 per person	1 machine category
IPAF2	£175 per person	2 machine categories
IPAF3	£225 per person	3 machine categories

Choose from Scissor Lift 3A, Mobile Boom 3B, Static Boom 1B



PASMA TRAINING

We offer a full range of PASMA training courses including; PASMA Towers for Users, PASMA Combined, PASMA Low Level Access, PASMA Towers for Managers, PASMA Towers for Stairs and PASMA Working at Height Essentials

PASMA TOWERS FOR USERS

This training is for anyone who needs to assemble, alter, dismantle, move, inspect and most importantly USE alloy or fibreglass Mobile Access Towers. This not only includes construction sites but all work places, such as schools, offices and factories, both internally and externally.

- Courses run at least twice weekly (Monday to Friday)
- Courses scheduled to customer demand for a minimum of 4 delegates
- Saturday training available (at an additional cost)
- Approved PASMA Training Centre
- On site training available (subject to certain requirements)
- Group discounts available
- Accredited by PASMA – PASMA card and certificate included, valid for 5 years
- Please visit our website or contact us for more details



PRICES

PASMA	£99 per person	PASMA Towers for Users
--------------	----------------	------------------------

We also run a range of other courses, please visit our website or contact us for more details



MARKONE ACCESS

Powered Access Hire Centre

Welton Way • Purdeys Ind. Estate
Rochford • Essex • SS4 1LA

Tel: **01702 561820**

Email: access@mark1hire.co.uk

Southend Hire Centre

Purdeys Way • Purdeys Ind. Estate
Rochford • Essex • SS4 1ND

Tel: **01702 545454**

Email: southend@mark1hire.co.uk

Rayleigh Hire Centre

34 Eastwood Road
Rayleigh • Essex • SS6 7JQ

Tel: **01268 745533**

Email: rayleigh@mark1hire.co.uk

Chelmsford Hire Centre

5 Argyll Road • Springfield
Chelmsford • Essex • CM2 6PY

Tel: **01245 399150**

Email: chelmsford@mark1hire.co.uk

Basildon Hire Centre

Unit 9 • Yardley Business Park
Pipps Hill • Basildon • SS14 3GL

Tel: **01268 904000**

Email: basildon@mark1hire.co.uk

ACCESS SPECIALIST TEAM **01702 561820**

www.mark1access.co.uk