

OPERATOR'S SAFETY AND SERVICE MANUAL

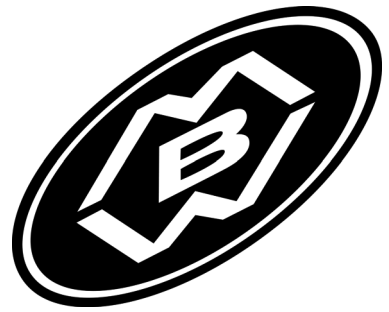

F36 F46

This manual covers the following serial numbers and higher,
for each model listed:

F36 3620751.
F46 4620250



WALK-BEHIND TROWELS

MBW, Inc.
250 Hartford Rd • PO Box 440
Slinger, WI 53086-0440
Phone: (262) 644-5234
Fax: (262) 644-5169
Email: mbw@mbw.com
Website: www.mbw.com

MBW (UK) Ltd.
Units 2 & 3
Cochrane Street
Bolton BL3 6BN, England
Phone: 01204 387784
Fax: 01204 387797

MBW France S.A.R.L
Phone: +33 (0) 3 44 07 15 96
Fax: +33 (0) 3 44 07 41 28

L21237.06.18.B
©MBW, Inc. 2015
Printed in the USA

TABLE OF CONTENTS

SAFETY INFORMATION	1	Storage.....	8
Introduction.....	1	Changing Trowel Blades	8
Safety Precautions	1	Setting Safety Switch	8
Safety Decals	1	Setting Tilt Arm Carriage Bolt Height	8
Safety Decals - EZ Pitch Handle	3	SERVICE	9
SPECIFICATIONS	4	Torque Chart	9
OPERATION	5	Service Tools	9
Introduction.....	5	Gearbox Disassembly	9
Before Starting & Operating	5	Gearbox Assembly.....	9
Starting Engine.....	5	Handle Removal/Installation.....	10
Operating	5	Gas Spring Replacement.....	10
Blade Pitch Adjustment (Standard).....	5	Low Vibration handle Cable Replacement.....	11
Blade Pitch Adjustment (E-Z Pitch)	5	Shorting Wire Replacement	11
Handle Bar Adjustment.....	5	Spider Bushing Removal	11
Stopping Engine	6	Spider Bushing Replacement.....	12
MAINTENANCE	7	Parts Replacement Cycles and Tolerances	12
Maintenance Schedule	7	REPLACEMENT PARTS	13
Fluid Levels.....	7	Gearbox Assembly.....	14
Engine Maintenance.....	7	Spider Assembly	16
Engine Oil	7	Drive Assembly	18
Engine Speed.....	7	Guard Assembly.....	20
Cleaning	7	Low Vibration Handle.....	22
Lubrication	7	EZ Pitch Handle Assembly.....	24
Lifting	8	WARRANTY	26

SAFETY INFORMATION

Introduction



This Safety Alert Symbol is used to call attention to items or operations which may be dangerous to those operating or working with this equipment. The symbol can be found throughout this manual and on the unit. Please read these warnings and cautions, along with all decals, carefully before attempting to operate the unit. Make sure every individual who operates or works with this equipment is familiar with all safety precautions.



GENERAL WARNING. Indicates information important to the proper operation of the equipment. Failure to observe may result in damage to the equipment and/or severe bodily injury or death.



GENERAL CAUTION. Indicates information important to the proper operation of the equipment. Failure to observe may result in damage to the equipment.

Safety Precautions



LETHAL EXHAUST GAS: An internal combustion engine discharges carbon monoxide, a poisonous, odorless, invisible gas. Death or serious illness may result if inhaled. Operate only in an area with proper ventilation. **NEVER OPERATE IN A CONFINED AREA!**



DANGEROUS FUELS: Use extreme caution when storing, handling and using fuels, as they are highly volatile and explosive in vapor state. Do not add fuel while engine is running. Stop and cool the engine before adding fuel. **DO NOT SMOKE!**



SAFETY GUARDS: It is the owner's responsibility to ensure that all guards and shields are in place and in working order.



IGNITION SYSTEMS: Breakerless, magneto, and battery ignition systems can cause severe electrical shocks. Avoid contacting these units or their wiring.



SAFE DRESS: Do not wear loose clothing, rings, wristwatches, etc. near machinery.

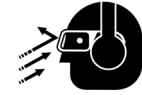

NOISE PROTECTION: Wear OSHA specified hearing protection devices.



EYE PROTECTION: Wear OSHA specified eye shields, safety glasses, and sweat bands.



HEAD PROTECTION: Wear OSHA specified safety helmets.



DUST PROTECTION: Wear OSHA specified dust mask or respirator.



OPERATOR: Keep children and bystanders off and away from the equipment.

REFERENCES: For details on safety rules and regulations in the United States, contact your local Occupational Safety and Health Administration (OSHA) office. Equipment operated in other countries must be operated and serviced in accordance and compliance with any and all safety requirements of that country. The publication of these safety precautions is done for your information. MBW does not by the publication of these precautions, imply or in any way represent that these are the sum of all dangers present near MBW equipment. If you are operating MBW equipment, it is your responsibility to insure that such operation is in full accordance with all applicable safety requirements and codes. All requirements of the United States Federal Occupational Safety and Health Administration Act must be met when operated in areas that are under the jurisdiction of that United States Department.

Safety Decals

Carefully read and follow all safety decals. Keep them in good condition. If decals become damaged, replace as required. If repainting the unit, replace all decals. Decals are available from authorized MBW distributors. Order the decal set listed on the following page(s).

12265

WARNING Start engine at idle only!
NEVER place foot on guard ring.



21186



21748

MBW POWER TROWEL

21192



12267

WARNING
Correct starting position!

PATENT PENDING

01504

WARNING
OPERATION OF THIS EQUIPMENT MAY CREATE SPARKS THAT CAN START FIRES AROUND DRY VEGETATION. A SPARK ARRESTER MAY BE REQUIRED. THE OPERATOR SHOULD CONTACT LOCAL FIRE AGENCIES FOR LAWS OR REGULATIONS RELATING TO FIRE PREVENTION.

19791

F36
POWER TROWEL

19962 - 36"
19963 - 46"

CAUTION

Read Operating Instructions before operating this piece of equipment.
Keep unauthorized and untrained people away from this equipment.
ROTATING & MOVING PARTS! Make sure all guards and safety devices are in place.
Wear OSHA approved hearing protection, foot protection, eye protection and head protection.
Avoid breathing dust from operating machine, wear OSHA specified dust mask/respirator.
SHUT OFF the motor before servicing or clearing.
DO NOT RUN in an enclosed area. The engine produces carbon monoxide, a **POISONOUS GAS**.
Failure to comply could result in serious bodily injury.

13483



12500

OPERATING INSTRUCTIONS

1. Check engine oil and trowel gearbox oil.
2. Open fuel valve, put engine switch on.
3. Put **SAFETY SWITCH** in ON position; set throttle to idle position.
4. Choke engine. A warm engine may not need to be choked.
5. Starting engine: Place one hand on trowel handle and other hand on engine starter rope. **NEVER** place foot on guard ring. Pull starter rope.
6. Open choke, allow engine to warm up at idle.
7. Position throttle for various operating conditions.
8. **TO STOP:** Return throttle to idle position, put safety switch to off position. Close fuel valve.

19970

WARNING
When lifting attach proper safety chains to hook. Approximate weight:
F46 Models: 260 lbs. (118 kg)
F36 Models: 209 lbs. (95 kg)

21188

WARNING
ROTATING PARTS can crush and cut. Keep hands away!

19971



01260



21371

MBW POWER TROWEL

21192

Safety Decals (Decal Kit #19975)

12265 **WARNING** Start engine at idle only!
NEVER place foot on guard ring.

EZ PITCH
21799

LOW VIBE
21186

PATENT PENDING
01504

M-B-W INC.
P.O. Box 440, Stinger, WI 53086
USA * ENGLAND
SAFETY SWITCH
ON
OFF
01260



WARNING
OPERATION OF THIS EQUIPMENT MAY
CREATE SPARKS THAT CAN START FIRES
AROUND DRY VEGETATION. A SPARK
ARRESTER MAY BE REQUIRED. THE
OPERATOR SHOULD CONTACT LOCAL FIRE
AGENCIES FOR LAWS OR REGULATIONS
RELATING TO FIRE PREVENTION
19791

MBW POWER TROWEL
21192

Safety Decals - EZ Pitch Handle

SPECIFICATIONS

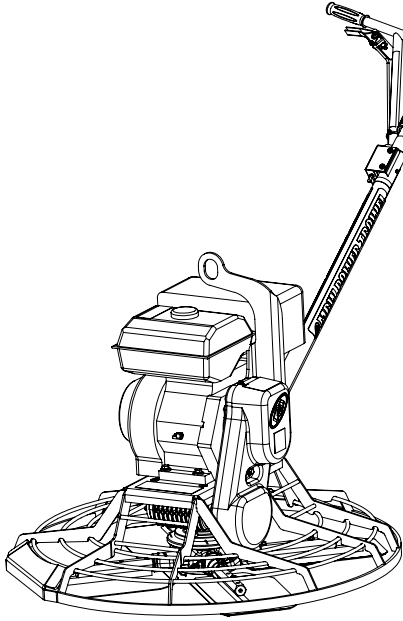

F36

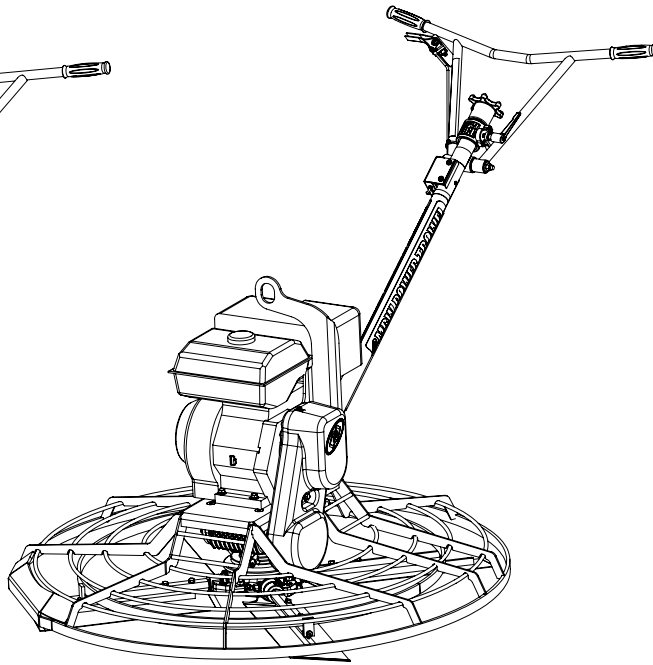

F46

	F36/4 - Blade	F46/4 - Blade
Guard Ring (Outside Diameter)	37-1/2 in (95 cm)	47-5/8 in (121 cm)
Blade Sweep Diameter	35.5" (90 cm)	46" (117 cm)
Blade Pitch	0 to 20°	
Trowel Rotor Speed	70 - 135 rpm	70 - 135 rpm
Low-Vibration Handle Height (Min./Max.)	35.8" - 43.3" (91 - 110 cm)	
Operating Overall Length	75" (191 cm)	80" (203 cm)
Gas Engines Options	Honda GX160 (9.9 in ³ /163cc) Honda GX270 (16.5 in ³ /270cc)	Honda GX270 (16.5 in ³ /270cc) Honda GX390 (23.7 in ³ /389cc)
Engine Speed	3400 rpm	3400 rpm
Operating Weight	183 lbs (83 kg) [GX160] 209 lbs (95 kg) [GX270]	246 lbs (112 kg) [GX270] 260 lbs (118 kg) [GX390]
Noise Level¹	85 - 105 dBA	85 - 105 dBA

Specifications subject to change without notice

1. Noise levels are based on operating conditions and will vary with background noise

OPERATION

Introduction

MBW equipment is intended for use in very severe applications. They are powered by four cycle engines and are available in different sizes and a selection of engines.

This parts manual contains only standard parts. Variations of these parts as well as other special parts are not included. Contact your local MBW distributor for assistance in identifying parts not included in this manual.

Before Starting & Operating

- **REMEMBER!** It is the owner's responsibility to communicate information on the safe use and proper operation of this unit to the operators.
- Review ALL of the Safety Precautions listed on page 1 of this manual.
- Familiarize yourself with the operation of the machine and confirm that all controls function properly.
- Know how to STOP the machine in case of an emergency.
- Make sure hands, feet, and clothing are at a safe distance from any moving parts.
- **NEW TROWELS** - After assembling the handle, inspect the throttle connections and confirm the remote throttle is actuating the engine throttle properly and all controls function properly.
- **FUEL SUPPLY** - The engines on MBW Power Trowels require a good grade of unleaded automotive gasoline. See the engine owner's manual for specific details. Engines are NOT approved to run E85 fuel.
- **ENGINE OIL** - Check the oil level in the engine. Refer to the Lubrication section of the engine owner's manual.
- **GEARBOX OIL** - Check the oil level in the trowel gearbox. Refer to the Maintenance section of this manual.
- **AIR CLEANER** - Check to make sure the element is in good condition and properly installed. Clean or replace filter element if clogged or damaged.

Starting Engine

1. Open fuel valve.
2. Turn engine switch to "ON".
3. Turn trowel safety switch to "ON".

4. Set throttle to idle.
5. Choke engine if necessary (you may not need to choke a warm engine).
6. Place one hand on the trowel handle and the other on the starter rope. Pull starter rope repeatedly until engine starts.



NEVER place foot inside the guard ring when starting.

7. Move choke lever to open position and allow engine to warm up for one or two minutes.

Operating

1. Increase throttle to engage the clutch.
2. Set throttle to desired position to achieve the appropriate trowel blade speed.
3. To move forward, push down on the right handle grip and pull up on the left handle grip.
4. To move backward, pull up on the right handle grip and push down on the left handle grip.
5. To move left, pull up on both handle grips.
6. To move right, push down on both handle grips.

Blade Pitch Adjustment (Standard)

1. To increase the pitch, rotate the tilt knob clockwise.
2. To decrease the pitch, rotate the tilt knob counterclockwise.

Blade Pitch Adjustment (E-Z Pitch)

1. To increase the pitch, squeeze the trigger and pull the lever towards you.
2. To decrease the pitch, squeeze the trigger and push the lever away from you.

Handle Bar Adjustment

Refer to Low Vibration Handle, page 22.

1. Rotate handle height adjustment lever (25) counter clockwise to loosen. If lever is tight to handle bar, pull out on lever and rotate away from handle bar and release lever.
2. Move handle bar to desired height.
3. Rotate handle height adjustment lever (25) clockwise to re-tighten.

4. If lever (25) is not parallel to handle bar when tight, pull out on lever and rotate lever and release lever when up against handle bar.

(Constant Force Handle)

1. Loosen bolt securing the handle bar to trowel handle.
2. Move handle bar to desired position.
3. Tighten bolt to lock handle.

Stopping Engine

1. Move throttle to idle position.
2. Turn trowel safety switch to "OFF".

3. Close the fuel valve.



Always stop the engine before:

Adding fuel.

Leaving the equipment unattended for any amount of time.

Before making any repairs or adjustments to the machine.

MAINTENANCE



WARNING



Always exercise the stopping procedure before servicing or lubricating the unit.

After servicing the unit, replace and fasten all guards, shields, and covers to their original positions before resuming operation.



CAUTION



Always verify fluid levels and check for leaks after changing fluids.

Do not drain oil onto ground, into open streams, or down sewage drains.

Maintenance Schedule

MAINTENANCE	10 HOURS OR DAILY	50 HOURS OR WEEKLY	100 HOURS OR MONTHLY	500 HOURS OR YEARLY
Grease yoke plate	X			
Grease spider	X			
Change gearbox oil				X
Check gearbox oil	X			
Inspect drive belt		X		
Check and tighten all hardware ¹			X	

1. Check all hardware after the first 5 hours of use, then follow the maintenance schedule.

Fluid Levels

SYSTEM	FLUID VOLUME	RECOMMENDED OIL
Gearbox Oil	21 oz. (620 ml)	#680 140wt Sulfur Free (MBW #05700)
Engine	Refer to engine operator/owner manual	

Engine Maintenance

Refer to the engine owner's manual for maintenance intervals and procedures.

Engine Oil

Refer to the engine owner's manual for recommended oil change intervals.



WARNING



Never change the oil when engine is hot. Allow engine to cool before maintaining.

To drain the oil, lift and tip the trowel forward onto the guard ring using the trowel handle. Place a drain pan underneath the engine and remove the drain plug. After the oil has finished draining, reinstall the plug and clean any spilled oil from the trowel.

Engine Speed

The engine speed is factory preset according to the Specifications section. Do not tamper with the governor settings. The governor establishes safe operating limits. These limits must not be exceeded.

Cleaning

Always clean the trowel thoroughly after each day's operation. Dried concrete buildup can hinder performance and shorten the life of the trowel.

Lubrication

- Grease the yoke plate and spider (see Spider Assembly, page 16) every 10 hours or daily with a lithium base, low temperature, general purpose lube.
- Change the gearbox oil once every season or 500 hours, whichever comes first. The drain/fill plug is located on the right-hand side of the gearbox. Fill it with 21 oz. (620 ml) of MBW Worm Gear Oil (MBW

#05700). The oil should be to the bottom of the fill hole when sitting level.

Lifting

The trowel should be lifted by the lifting bracket attached to the engine. As an alternative, it may be lifted by two people on opposite sides of the guard ring.

Storage

The trowel should be stored with blocks supporting the outer guard ring. Refer to the engine owner's manual for information regarding storage of the engine.

Changing Trowel Blades



Trowel blade edges may be sharp when they are worn. Wear protective gloves when handling the blades.

1. Set the trowel on a level surface.
2. Remove the bolts securing the blade to the tilt arm.
3. Lift up on the ring guard and slide the blade out from under the tilt arm.
4. Slide the new blade under the tilt arm.
5. Reinstall the bolts and tighten.
6. Check that the carriage bolts are set properly. If they require adjustment refer to the "Setting Tilt Arm Carriage Bolt Height" section.

Setting Safety Switch

Refer to Low Vibration Handle, page 22.

1. Remove screws (12) & lock washers (28) securing safety switch assembly to handle tube (25).

2. Remove inside cover and set screw to dimension shown in figure 5, in the Service Section of this manual.

Setting Tilt Arm Carriage Bolt Height

1. Remove **ALL** the tilt arms from the spider.
2. Remove the blades from all the arms. Wear protective gloves when removing the blades, the edges may be sharp
3. Inspect the bottom side of the arms (blade mounting surface). Remove any nicks, cement, etc. **THIS SURFACE MUST BE FLAT**
4. Loosen the jam nut and run the carriage bolt in as far as possible.
5. Mount the arm to gage #07277 as shown in figure 2.

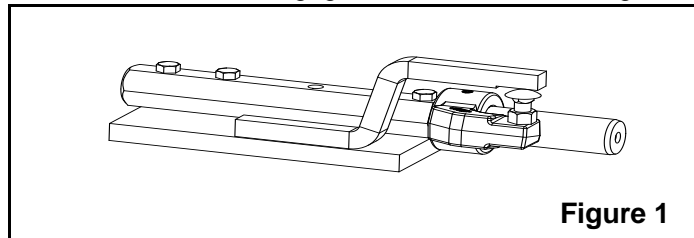

Figure 1

6. Place a .030 feeler gage between the carriage bolt and the underside of the gage arm, and run the carriage bolt up to just contacting the feeler gage. There should be a slight drag felt when the feeler gage is moved between the two surfaces.
7. Place a 3/8" open end wrench on the square shoulder of the carriage bolt and tighten the jam nut. **DO NOT** allow the carriage bolt to turn.
8. Recheck clearance with feeler gage and readjust if necessary.
9. Repeat items 5 through 8 for **ALL** remaining tilt arms.
10. Lubricate the tilt arm prior to fitting it in spider.

SERVICE

Assembly and disassembly should be performed by a service technician who has been factory trained on MBW equipment. The unit should be clean and free of debris. Pressure washing before disassembly is recommended.

- Prior to assembly, wash all parts in a suitable cleaner or solvent.
- Check moving parts for wear and failure. Refer to the Replacement section in this manual for tolerance and replacement cycles.
- All shafts and housings should be oiled prior to pressing bearings. Also, ensure that the bearings are pressed square and are seated properly.
- All bearings, seals, o-rings and gaskets should be replaced when rebuilding gearbox.

Torque Chart

SIZE	GRADE 2	GRADE 5	GRADE 8
1/4-20	49 in•lbs	76 in•lbs	9 ft•lbs
1/4-28	56 in•lbs	87 in•lbs	10 ft•lbs
5/16-18	8 ft•lbs	13 ft•lbs	18 ft•lbs
5/16-24	9 ft•lbs	14 ft•lbs	20 ft•lbs
3/8-16	15 ft•lbs	23 ft•lbs	33 ft•lbs
3/8-24	17 ft•lbs	26 ft•lbs	37 ft•lbs
7/16-14	24 ft•lbs	37 ft•lbs	52 ft•lbs
7/16-20	27 ft•lbs	41 ft•lbs	58 ft•lbs
1/2-13	37 ft•lbs	57 ft•lbs	80 ft•lbs
1/2-20	41 ft•lbs	64 ft•lbs	90 ft•lbs
9/16-12	53 ft•lbs	82 ft•lbs	115 ft•lbs
5/8-11	73 ft•lbs	112 ft•lbs	159 ft•lbs
5/8-18	83 ft•lbs	112 ft•lbs	180 ft•lbs
3/4-16	144 ft•lbs	200 ft•lbs	315 ft•lbs
1-8	188 ft•lbs	483 ft•lbs	682 ft•lbs
1-14	210 ft•lbs	541 ft•lbs	764 ft•lbs
1-1/2-6	652 ft•lbs	1462 ft•lbs	2371 ft•lbs
M 6	3 ft•lbs	4 ft•lbs	7 ft•lbs
M 8	6 ft•lbs	10 ft•lbs	18 ft•lbs
M 10	10 ft•lbs	20 ft•lbs	30 ft•lbs

CONVERSIONS

in•lbs x 0.083 = ft•lbs

ft•lbs x 12 = in•lbs

ft•lbs x 0.1383 = kg•m

ft•lbs x 1.3558 = N•m

Service Tools

Part No.	Description
07276	Adjustment Tool, Tilt Arm Parallelism
07277	Adjustment Tool, Tilt Arm Height Gage
07279	Installation Tool, Spider Bushing (#06459)
16421	Bearing Spool Tool (Constant Force)

Gearbox Disassembly

Refer to Gearbox Assembly, page 14.

1. Remove the handle, belt guard & drive assembly (page 18), engine & guard ring (page 20).
2. Loosen the square head set screw (page 16, #19) until the gearbox housing can be lifted off the spider assembly.
3. Flip gearbox housing (7) over and set it on guard ring pads.
4. Remove the yoke arm (9) by removing one of the retaining rings (6), holding the pivot rod (12) and sliding the rod out of the holes.
5. Remove the two flange bolts (29) and the two flat head screws (30) that hold cover (8) to the gearbox housing (7).
6. Remove the cover and discard the shims (11) and the o-ring (5).
7. Pull out the shaft (14) with bearings (3) and worm gear (13) and drain oil out of gearbox.
8. Press bearing (3) and worm gear (13) off long side of shaft (14).
9. Remove key (15) and retaining ring (2) from shaft.
10. Press remaining bearing (3) off of shaft.
11. Remove flange bolts (28) and bearing cap (22). Discard gasket (10) and o-ring (18).
12. Remove the worm shaft (20) and bearings (23).
13. Remove retaining cap (21) and discard shim gasket (#10) and the o-ring (18).

Gearbox Assembly

Refer to Gearbox Assembly, page 14.

1. Lightly oil shaft (14). Install the key (15) and retaining ring (2) onto the shaft.
2. With the retaining ring end of shaft down, press worm gear (13) onto shaft. Make sure longer hub of the worm gear is down. Worm gear should be pressed on

the shaft until the recess in worm gear hub is snug against retaining ring.

3. Press one bearing (3) on each end of the shaft. Make sure bearings are butted against worm gear shoulders.
4. If bearing races are replaced make sure new races are properly seated.
5. Set worm gear and shaft assembly into gearbox housing and put cover (8) and one.010" shim #05401 (11) into place.
6. Apply down pressure to cover (8) and check shaft (14) for end play.
7. Remove the cover and install the proper shims (11) for no end play.
8. Brush a light coat of oil on o-ring groove and inside lip of cover. Roll o-ring (5) over inside lip and into groove in cover. Install seal (1) into cover from outside and make sure it is installed square and flat. Then secure with retaining ring (17).
9. Use a piece of thin plastic over shaft to protect seal and install cover into gearbox housing. Secure with two flange bolts (24) and two flat head screws (30).
10. Rotate shaft, there should be a little drag. If there is too much drag another shim should be added until a slight seal drag is felt. If there is side play in the shaft a shim must be removed.
11. Measure the main shaft run out, Maximum acceptable total indicator run out is .0035 inches.
12. Install drain plug (31) and relief valve (16) if removed. Use pipe sealant on the threads.
13. Brush a light coat of oil on o-ring (18). Roll it over inside lip and into the groove of retaining cap (22).
14. Install two.010" shims #05360 (#10) with retaining cap on drain plug side of gearbox housing with four flange bolts (28). Torque bolts to 90 in/lbs in an "X" pattern.
15. Press one bearing (23) on each end of the worm shaft (20). Make sure bearings are butted against worm shaft steps.
16. Install worm shaft (20) with bearings (23) into gearbox housing. Gears must be meshed properly.
17. Install bearing cap (21) and apply pressure towards gearbox (7). Rotate worm shaft and check for end play and gear backlash.
18. Remove bearing cap and install proper shims (10) for no back lash & no end play.
19. Install a new seal (19) into bearing cap (21) from outside. Make sure seal is installed square and flat.
20. Brush a light coat of oil on o-ring groove. Roll o-ring (#18) over inside lip and into groove of bearing cap.
21. Pour one can (21 oz.) of #05700 oil into worm shaft bearing cap opening. Install cap and secure with four

flange bolts (#28). Torque bolts to 90 in/lbs in an "X" pattern.

Handle Removal/Installation

Refer to Low Vibration Handle, page 22.

1. Remove bottom lock nut (40) from pitch cable (6).
2. Slide pitch cable end out of pivot pin (7) and remove jam nut (41) from pitch cable (6).
3. Disconnect shorting wires (10) from engine.
4. Disassemble throttle wire from engine.
5. Remove screws (39), washers (36) and lock nuts (40) from handle tube (25) and slide handle off of gear box tube. **For F36 only**, remove top screw only (32), washers (34) & lock nut (33) in gear box tube, loosen only the lower screw (32), **see Gearbox assembly page 14.**
6. Slide the handle assembly off the handle mounting tube.
7. To re-assemble the handle, slide the handle assembly on to the handle mounting tube, guiding pitch cable end thru cable slide, F46 only.
8. Install screws (39), washers (36) and lock nuts (40). **For F36 only**, install top screw (32), washers (34) & lock nut (33) in gear box tube, tighten lower screw loosened in step #5, **see gearbox assembly page 14**
9. Assemble hex jam nut (41) to pitch cable (6)
10. Slide the threaded end of the pitch cable (6) into the pivot pin (7) and assemble lock nut (40) to cable (6).
11. Route safety switch wire between engine and belt guard and reconnect to engine.
12. Install throttle wire to engine.

Gas Spring Replacement

Refer to EZ Pitch Handle Assembly, page 24.



1. Move the EZ pitch handle to the most extend, pitched, position to take pressure of the gas spring, see figure #2.
2. See the "Handle Removal" section of the manual to remove the handle from the trowel.
3. Remove flange lock nut (46) securing gas spring (33) to bracket (29).
4. Remove button head screw (37) and washer (7) from tube (27) just below gear assembly (30).
5. Slide EZ pitch assembly out of top of tube (27).
6. Unhook EZ pitch lever (34) from pitch cable links (31).

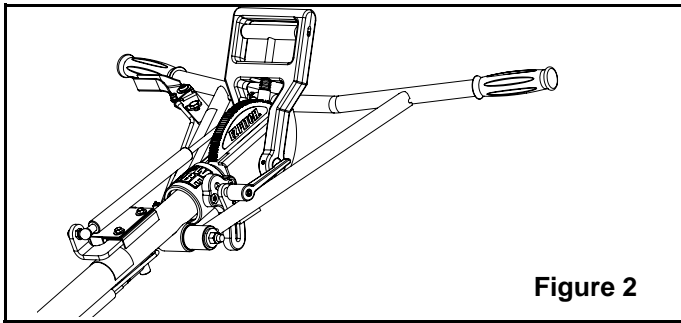

7. Remove three spiral pins(36) from activating shaft (13), handle (10) and EZ pitch lever (34).
8. Slide activating shaft (13) out of gear assembly (30) and remove handle assembly (10).
9. Remove gas spring (33) from handle assembly (10) and replace with new gas spring.
10. Slide activating shaft (13) thru handle (10), gear assembly (30) and EZ pitch lever (34) and reinstall spiral pins (36). Note position of EZ pitch lever (34).
11. Lock handle assembly (10) in extended position as shown in figure #2.
12. Slide pitch cable links (31) into gear assembly (30) over top of activating shaft (13) and hook into EZ pitch lever (34).
13. Slide EZ pitch assembly into top of handle tube (27), guiding cable into top of cable slide (28) F36 handle only, see figure #3.
14. Align hole in gear assembly (10) with hole in top of handle tube (27) and install washer (7) and button head screw (37) with blue loctite.
15. Assemble bottom end of gas spring (33) to mounting bracket (29) with lock nut (46).
16. Reinstall handle assembly to trowel per the "Handle Removal/installation" section of this manual.

Low Vibration handle Cable Replacement

Refer to Low Vibration Handle, page 22.

1. See the "Handle Removal" section of the manual to remove the handle from the trowel.
2. Remove screws (12), washers (28) and remove safety switch assembly (#14).
3. Turn pitch control knob all the way counterclockwise.
4. Remove button head screw (30) and washer (11) from tube below pitch control knob (3).
5. Remove socket head screw (34) from slot on right side of handle tube(25).
6. Slide pitch cable assembly out top of tube, guiding threaded end thru cable slide on bottom end of tube.

7. Remove button head screw (33) from shaft adapter (26) to remove cable (6).
8. Assemble new cable(6) to shaft adapter (26), with screw (33), note cable position for F36 or F46 handle

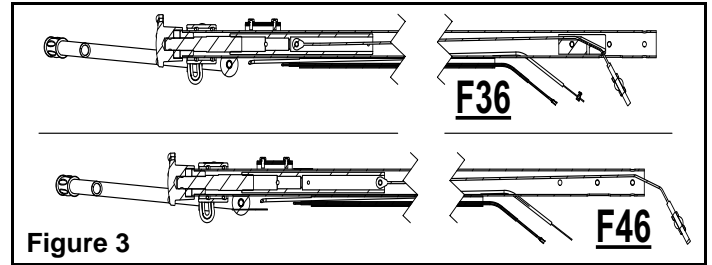

9. Slide pitch cable assembly into top of handle tube (25), guiding cable into top of cable slide (27), F36 handle, see figure #3.
10. Install socket head screw (34) to shaft adapter (26) thru slot on right side of handle tube (25).
11. Align hole in bearing (4) with hole in top of handle tube (25) and install button head screw (30) and washer (11).
12. Slide handle assemble on handle mounting tube on gear box & reinstall hardware removed in the "Handle Removal" section of this manual.

Shorting Wire Replacement

Refer to Low Vibration Handle, page 22.

1. Assemble wire harness (15) to both screws on safety switch (11) and reset screw height as shown in Figure 5.
2. Remove short wire with 1/4" ring terminal from end of harness (15). Route harness inside small tube on handle (16) & between engine and belt guard as shown in Figure 6.
3. Connect bullet terminal to engine shut-off switch wire. Reattach short wire and assemble 1/4" ring terminal to lower right engine shroud screw as shown in Figure 6.

Spider Bushing Removal

Refer to Figure #7

1. Screw a 3/4-14 pipe tap about half way into the worn outer bushing.
2. Insert a 3/4" x 8 1/2" push rod into the opposite side of the spider.
3. Use a 1 1/4" x 4" tube on upper end to press old bushings out.
4. Repeat with inner bushings.

Spider Bushing Replacement

Refer to Figure #8 for bushing installation:

1. Install (4) inner bushings into spider, using long side of installation tool #60703 to ensure proper bushing depth.

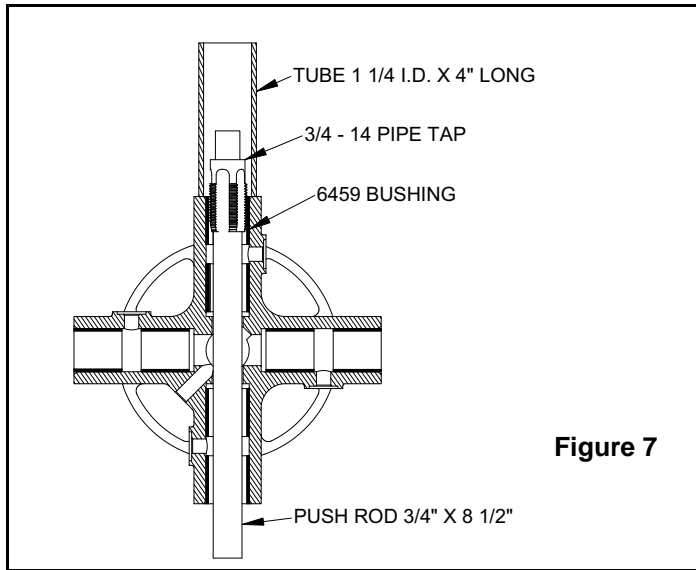

Figure 7

2. Using the opposite end or short end of installation tool #60703, install (4) outer bushings into spider.

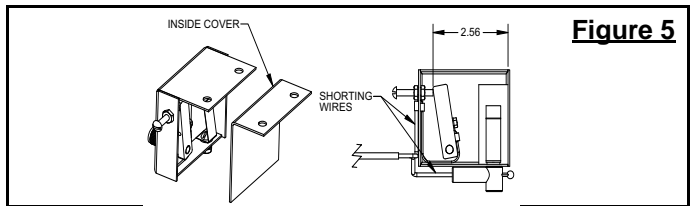

Figure 5

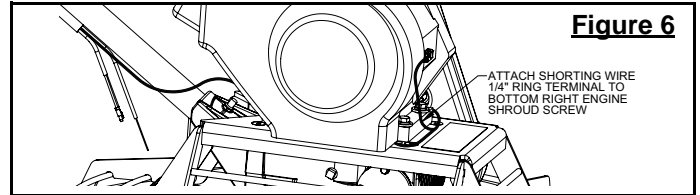

Figure 6

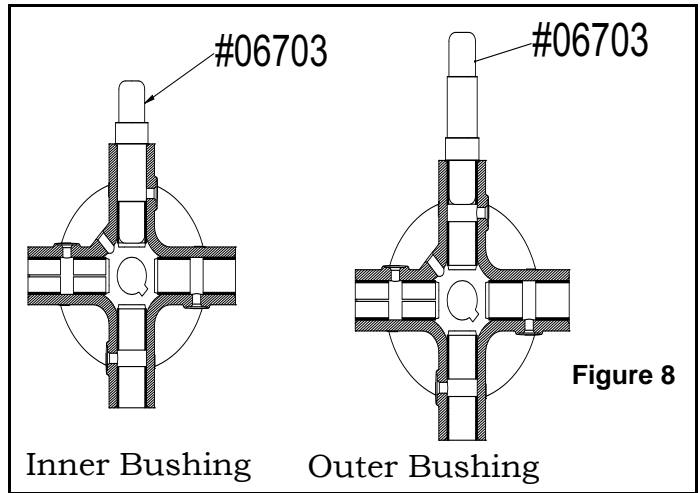

Figure 8

Parts Replacement Cycles and Tolerances

Air Cleaner Element	Replace after 100 hours if the engine is operating under good clean air conditions. Service and replace more frequently if under more severe conditions.
Bearings	Replace anytime a bearing is rough, binding, discolored or removed from housing or shaft.
Blades	Replace when the edges become sharp or uneven. (Finish blades can be reversed)
Bushings, Trowel Arm	Replace if the trowel arm can be moved up and down more than 3/4 inch (19 mm) at the end of the arm.
Carriage Bolts	Reset the height after trowel arm teardown or if the trowel develops chatter or windmilling. Use height gage kit #07277 when setting.
Clutch	Replace clutch if it does not disengage below 2000 rpm.
Gaskets and Seals	Replace at every overhaul and teardown. Use MBW gasket and seal kit #05470.
Gearbox Oil	Replace after the first 50 hours of operation, then every 500 operating hours or yearly thereafter.
Spark Plug	Change after 75 hours of operation.
Torque Bolts	Re-torque all the bolts after the first eight hours of operation and check every 25 hours thereafter.
Worm Gear	Replace if the teeth show wear marks or become sharp.
Worm Shaft	Replace if the teeth show wear marks or become sharp.

REPLACEMENT PARTS

The warranty is stated in this book on page 26. Failure to return the Warranty Registration Card renders the warranty null and void.

MBW, Inc. has established a network of reputable distributors with trained mechanics and full facilities for maintenance and rebuilding, and to carry an adequate parts stock in all areas of the country. Their sales engineers are available for professional consultation. If you cannot locate an M-B-W distributor in your area, contact MBW, Inc. or one of our Sales Branches listed below.

When ordering replacement parts, be sure to have the following information available:

- Model and Serial Number of machine when ordering M-B-W parts
- Model and Serial Number of engine when ordering engine parts
- Part Number, Description, and Quantity
- Company Name, Address, Zip Code, and Purchase Order Number
- Preferred method of shipping

REMEMBER - You own the best! If repairs are needed, use only M-B-W parts purchased from authorized M-B-W distributors.

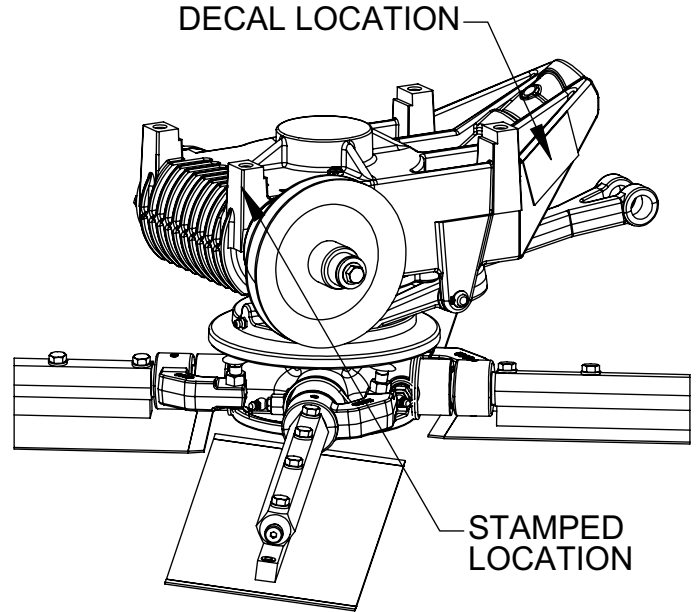

The unit's serial number can be found in the following locations:

- The model/serial number decal is located on the rear side of the gearbox, next to the engine and beltguard.
- The serial number is stamped on the front of the gearbox.

Write Model Number here

Write Serial Number here

Contact Information

MBW, Inc.
250 Hartford Rd • PO Box 440
Slinger, WI 53086-0440
Phone: (262) 644-5234
Fax: (262) 644-5169
Email: mbw@mbw.com
Website: www.mbw.com

MBW (UK) Ltd.
Units 2 & 3
Cochrane Street
Bolton BL3 6BN, England
Phone: 01204 387784
Fax: 01204 387797

MBW France S.A.R.L
Phone: +33 (0) 3 44 07 15 96
Fax: +33 (0) 3 44 07 41 28

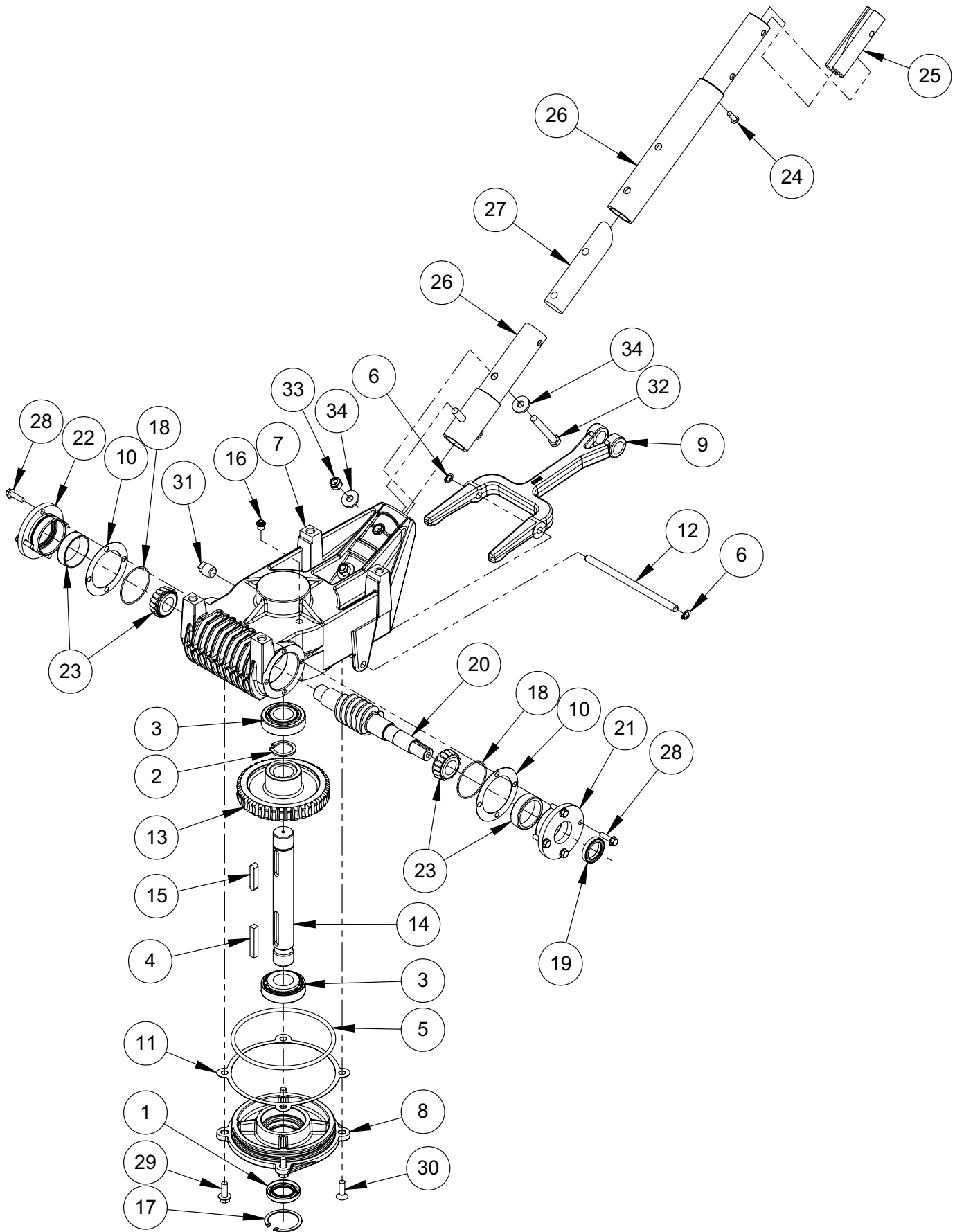

Gearbox Assembly

ITEM	PART NO.	DESCRIPTION	F36"	F46"
1.	01243	SEAL, GEAR SHAFT	1	1
2.	01244	RETAINING RING, EXTERNAL	1	1
3.	01251	BEARING TAPER ROLLER (Includes Bearing & Cup)	2	2
4.	01254	KEY, 5/16 SQUARE x 2 lg.	1	1
5.	01256	O-RING	1	1
6.	01279	RETAINING RING, EXTERNAL	2	2
7.	05323	HOUSING, GEARBOX	1	1
8.	05326	COVER, GEARBOX	1	1
9.	05329	ARM, YOKE	1	1
10.	05359	SHIM GASKET, 0.004"		
	05360	SHIM GASKET, 0.010"		
11.	05361	SHIM GASKET, 0.004"		
	05401	SHIM GASKET, 0.010"		
12.	05396	ROD, PIVOT	1	1
13.	05521	GEAR, WORM	1	1
14.	05523	SHAFT, OUTPUT	1	1
15.	05524	KEY, 5/16" SQUARE x 1-11/16" LONG	1	1
16.	06037	VALVE, RELIEF	1	1
17.	06264	RETAINING RING	1	1
18.	06392	O-RING	2	2
19.	11075	SEAL, INPUT SHAFT	1	1
20.	19637	SHAFT	1	1
21.	19638	BEARING CAP	1	1
22.	19639	CAP, RETAINING	1	1
23.	19687	BEARING TAPER ROLLER (Includes Bearing & Cup)	2	2
24.	21009	HI-LOW SCREW, 1/4 x 3/4, TORX		1
25.	21585	CABLE SLIDE, TROWEL HANDLE		1
26.	21586	TUBE, MOUNT, HANDLE, F36	1	
	21588	TUBE, MOUNT, HANDLE, F46		1
27.	21590	SPACER, HANDLE TUBE, F46		1
28.	F042007FWS	FLANGE BOLT, 1/4-20 x 7/8"	8	8
29.	F051807FWS	FLANGE BOLT, 5/16-18 x 7/8"	2	2
30.	F051808FSS	FLAT HEAD SCREW, 5/16-18 x 1"	2	2
31.	F0618SHPP	PIPE PLUG, 3/8"	1	1
32.	F061622HCS	HEX HEAD SCREW, 3/8-16 x 2-3/4, GR8, ZP	2	2
33.	F0616ELN	LOCK NUT, 3/8-16, NYLOC, ZP	2	2
34.	F06SW	FLAT WASHER, 3/8, ZP	4	4
		REPLACEMENT KITS		
	19940	KIT, GASKET & SEAL (includes 1, 11, 12, 19 & 20)		
	19636	GEARBOX ASSEMBLY (includes all above items)		
	05700	GEAR OIL, CHEVRON #680		

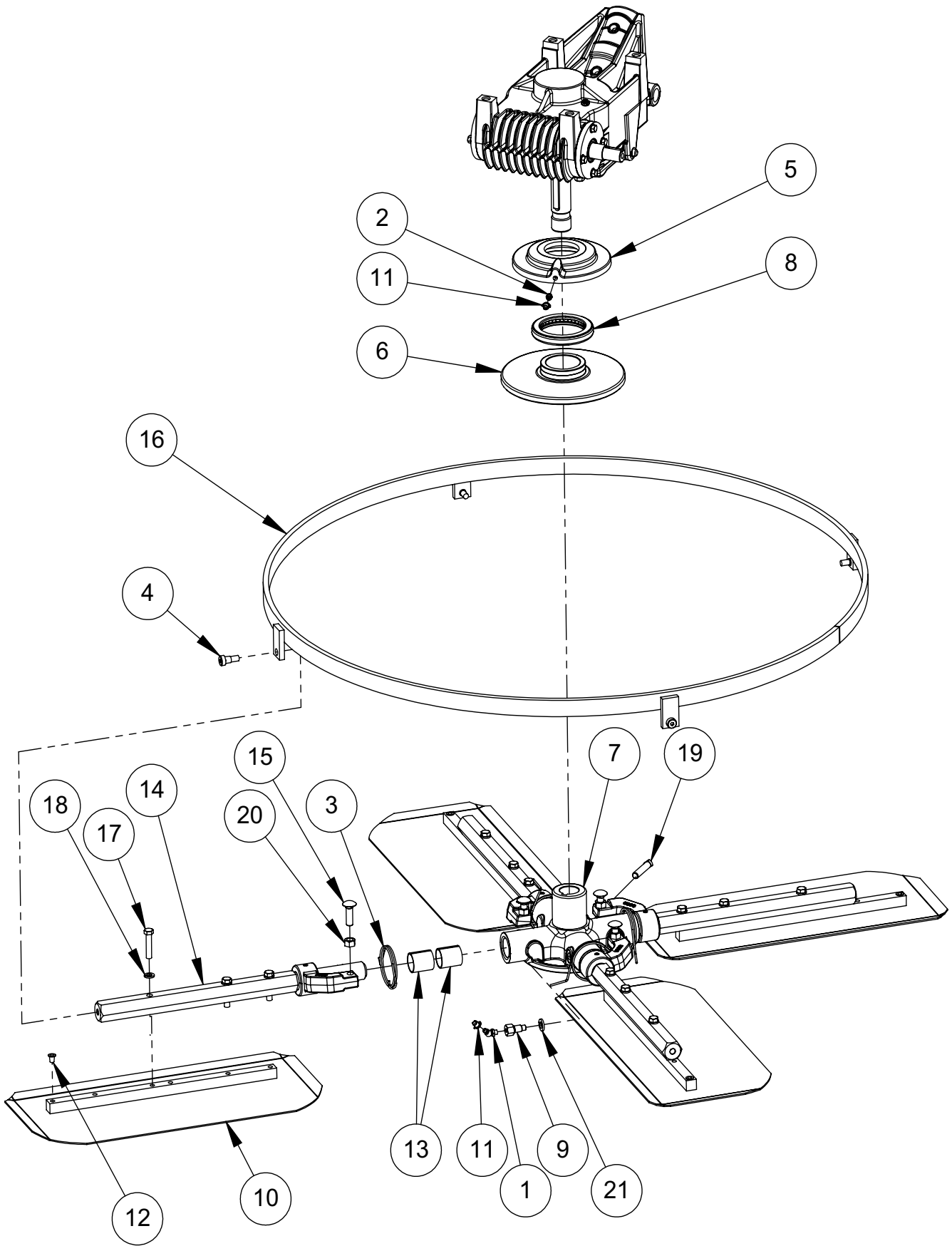

Spider Assembly

ITEM	PART NO.	DESCRIPTION	F36/4	F46/4
1.	01169	GREASE FITTING, 45	4	4
2.	01177	GREASE FITTING, STRAIGHT	1	1
3.	01258	SPRING	4	4
4.	01280	SOCKET HEAD SHOULDER SCREW, 3/8" x 3/8"		4
5.	05324	YOKE PLATE	1	1
6.	05330	PRESSURE PLATE, 4-ARM*	1	1
7.	05331	SPIDER, 4-ARM (includes 13)*	1	1
8.	05356	BEARING	1	1
9.	05397	BOLT, HOLLOW	4	4
10.	05402	COMBINATION BLADE, 8" x 14"	4	
	05412	COMBINATION BLADE, 8" x 18"		4
11.	05492	CAP, GREASE	5	5
12.	05968	CAPLUG (set of 12)	4	4
13.	06459	BUSHING, SPLIT	8	8
14.	06755	TILT ARM, 36" (includes 15 & 20)	4	
	21368	TILT ARM, 46" (includes 15 & 20)		4
15.	17190	CARRIAGE BOLT (SPECIAL), 3/8-16 x 1-1/4"	4	4
16.	21230	STABILIZER, 4-ARM*		1
17.	F051812HCS	HEX HEAD CAP SCREW, 5/16-18 x 1-1/2"	8	12
18.	F05LW	LOCKWASHER, 5/16"	8	12
19.	F061614SHS	SQUARE HEAD SET SCREW, 3/8-16 x 1-3/4"	1	1
20.	F0616HN	HEX NUT, 3/8-16	4	4
21.	F06LW	LOCKWASHER, 3/8"	4	4
		REPLACEMENT KITS		
	01427	GREASE FITTING CAPS (sold in sets of 12)	5	5
	06199	SPIDER & ARM ASSEMBLY, (includes 1, 3, 7, 9, 11, 14, 15, 19, 20 & 21)	1	
	21369	SPIDER & ARM ASSEMBLY, (includes 1, 3, 7, 9, 11, 14, 15, 19, 20 & 21)		1
	07524	PRESSURE PLATE ASSEMBLY, 4-ARM (includes 2, 5, 6, 8 & 11)	1	1
		OPTIONAL BLADES:		
	05347	FINISH BLADE, 6" x 14"	4	
	05383	FINISH BLADE, 6" x 18"		4
	05403	FLOAT BLADE, 10" x 14"	4	
	07935	FLOAT BLADE, 10" x 18"		4

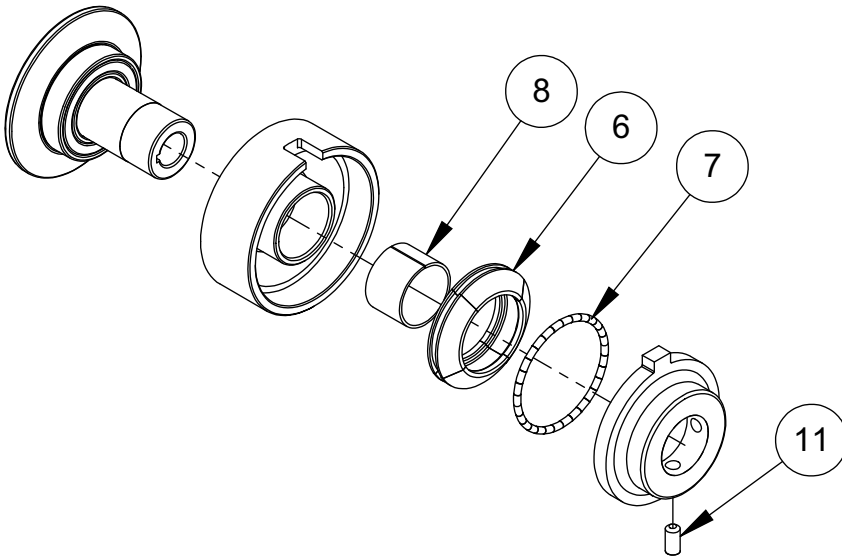
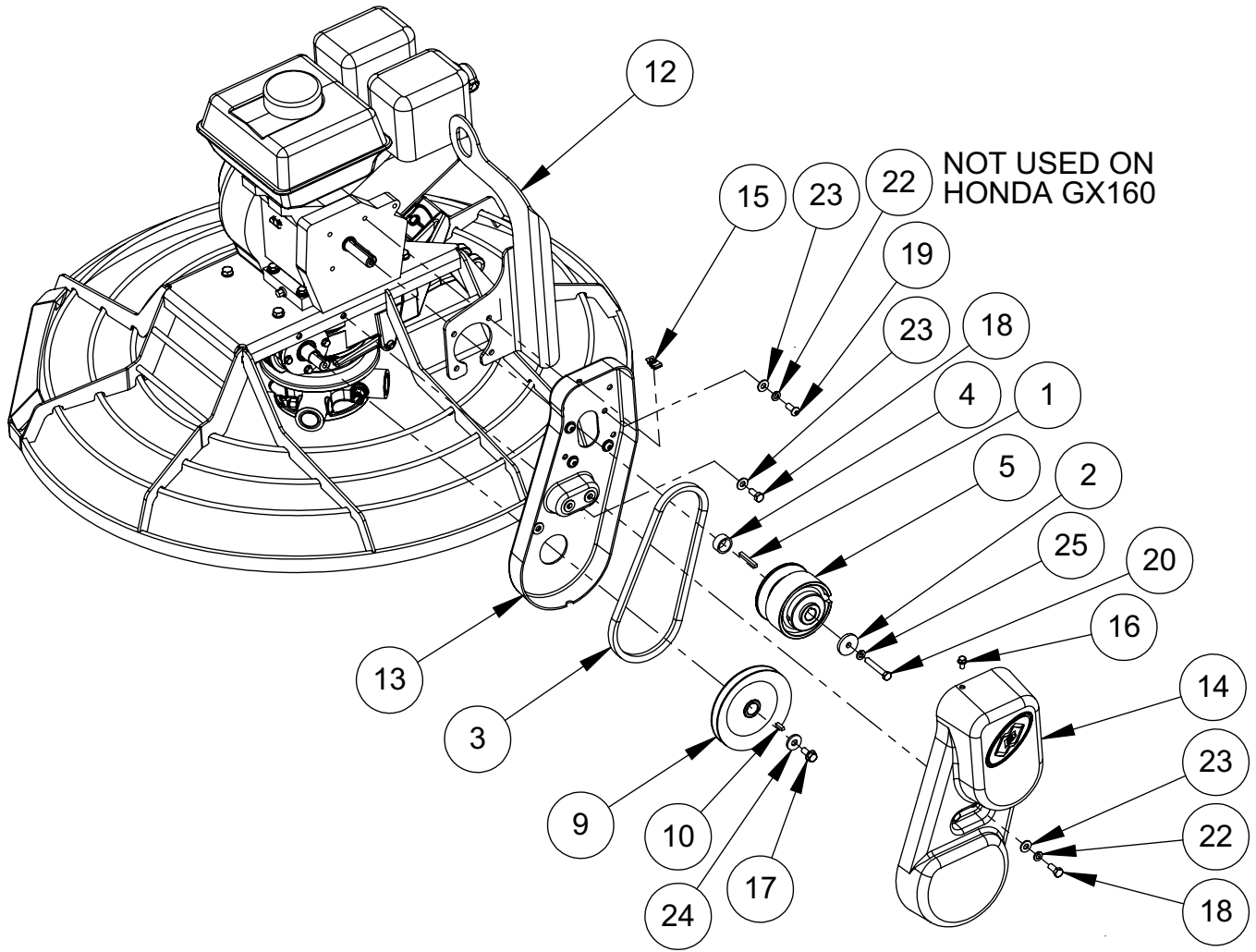

Drive Assembly

ITEM	PART NO.	DESCRIPTION	GX160	GX270	GX390
1.	00032 01161	KEY, 3/16" SQUARE x 1-5/8" LONG KEY, 1/4" SQUARE x 1-1/2" LONG	1	1	1
2.	01099 06638	WASHER, 5/16" SPECIAL WASHER, 3/8" SPECIAL	1	1	1
3.	01289 01078	V-BELT, A-27 V-BELT, A-29	1	1	1
4.	06378	SPACER	1	1	
5.	06473	CLUTCH 3/4" BORE (includes 6,7,8 & 11)	1		
6.	06606 06618	CLUTCH 1" BORE (includes 6, 7, 8 & 11) WEIGHT (set of 4)	1	1	1
7.	06619	SPRING	1	1	1
8.	06620	BEARING	1	1	1
9.	06746	SHEAVE	1	1	1
10.	06858	KEY, 3/16" SQUARE x 5/8" LONG	1	1	1
11.	19401	SCOCKET HEAD CUP POINT SET SCREW, 5/16-18x5/8	1	1	1
12.	19370	LIFTHOOK, TROWEL (For engines 5-7 hp.)	1		
13.	19372 19666	LIFTHOOK, TROWEL (For engines 9-13 hp.) BELT GUARD, BACK PLATE ASSEMBLY (Includes item #15)	1	1	1
14.	19668	BELT GUARD, FRONT COVER	1	1	1
15.	19804	CLIP NUT, 1/4-20	1	1	1
16.	F042004FWS	FLANGE SCREW, 1/4-20 x 1/2"	1	1	1
17.	F051806FWS	FLANGE SCREW, 5/16-18 x 3/4"	1	1	1
18.	F051808HCS	HEX HEAD CAP SCREW, 5/16-18 x 1"	4	4	4
19.	F052406BCS	BUTTON CAP SCREW, TORX, 5/16-24 x 3/4"	4		
20.	F052408HCS F052416HCS	HEX HEAD CAP SCREW, 5/16-24 x 1" HEX HEAD CAP SCREW, 5/16-24 x 2"	1	4	4
	F072012HCS F062410SCS	HEX HEAD CAP SCREW, 7/16-20 x1-1/2 SCOCKET HEAD CAP SCREW, 3/8-24 x 1-1/4		1	1
21.	F0518ELN	NYLON LOCKNUT, 5/16-18	2	2	2
22.	F05LW	LOCKWASHER, 5/16"	2	6	6
23.	F05SW	WASHER, 5/16	8	8	8
24.	F06SW	WASHER, 3/8"	1	1	1
25.	F05LW F07LW	LOCKWASHER, 5/16" LOCKWASHER, 7/16"	1	1	
	F06LW	LOCKWASHER, 3/8"			1

GX160

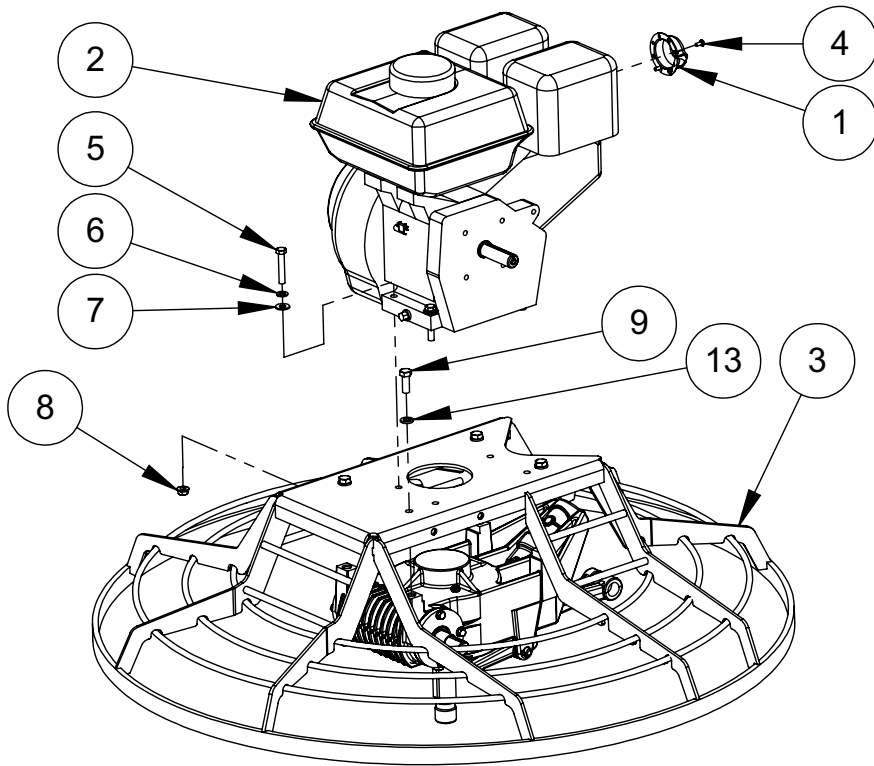

GX270 THRU GX390

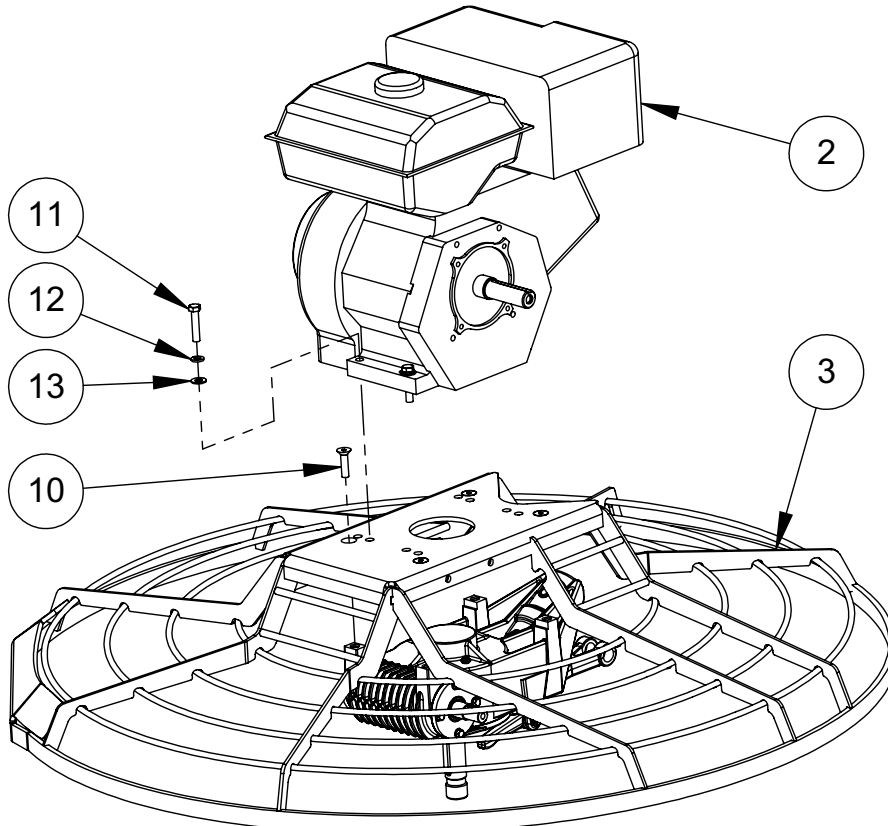

Guard Assembly

ITEM	PART NO.	DESCRIPTION	GX160	GX270/GX390
1.	07636	EXHAUST DEFLECTOR	1	
2.	01444	HONDA ENGINE, GX160	1	
	15674	HONDA ENGINE, GX270		1
	12887	HONDA ENGINE, GX390		1
3.	21201	GUARD RING, 36" EDGER	1	
	21338	GUARD RING, 36" (GX270) EDGER		1
	21216	GUARD RING, 46" EDGER		1
4.	F0203PTS	PAN HEAD TAP SCREW. #8 x 3/8" LG.	2	
5.	F051814HCS	HEX HEAD CAP SCREW, 5/16-18 x 1-3/4"	4	
6.	F05LW	LOCK WASHER, 5/16"	4	
7.	F05SW	FLAT WASHER, 5/16"	4	
8.	F0518FN	FLANGE NUT, 5/16-18	4	
9.	F061608HCS	HEX HEAD CAP SCREW, 3/8-16 x 1" (5-7 HP)	4	
10.	F061608FSS	FLAT HEAD SCREW, 3/8-16 x 1" LG. (9-13 HP)		4
11.	F061614HCS	HEX HEAD CAP SCREW, 3/8-16 x 1-3/4"		4
12.	F06LW	LOCKWASHER, 3/8" (GUARD RING 5-7 HP ONLY)		4
13.	F06PW	PLAIN WASHER, 3/8"		4
		REPLACEMENT KITS		
	Q2893881	AIR FILTER, GX100, HONDA ENGINE		
	Q5266721	AIR FILTER, GX270, HONDA ENGINE		
	Q2893907	AIR FILTER, GX390, HONDA ENGINE		

"UK" HANDLE ASM.

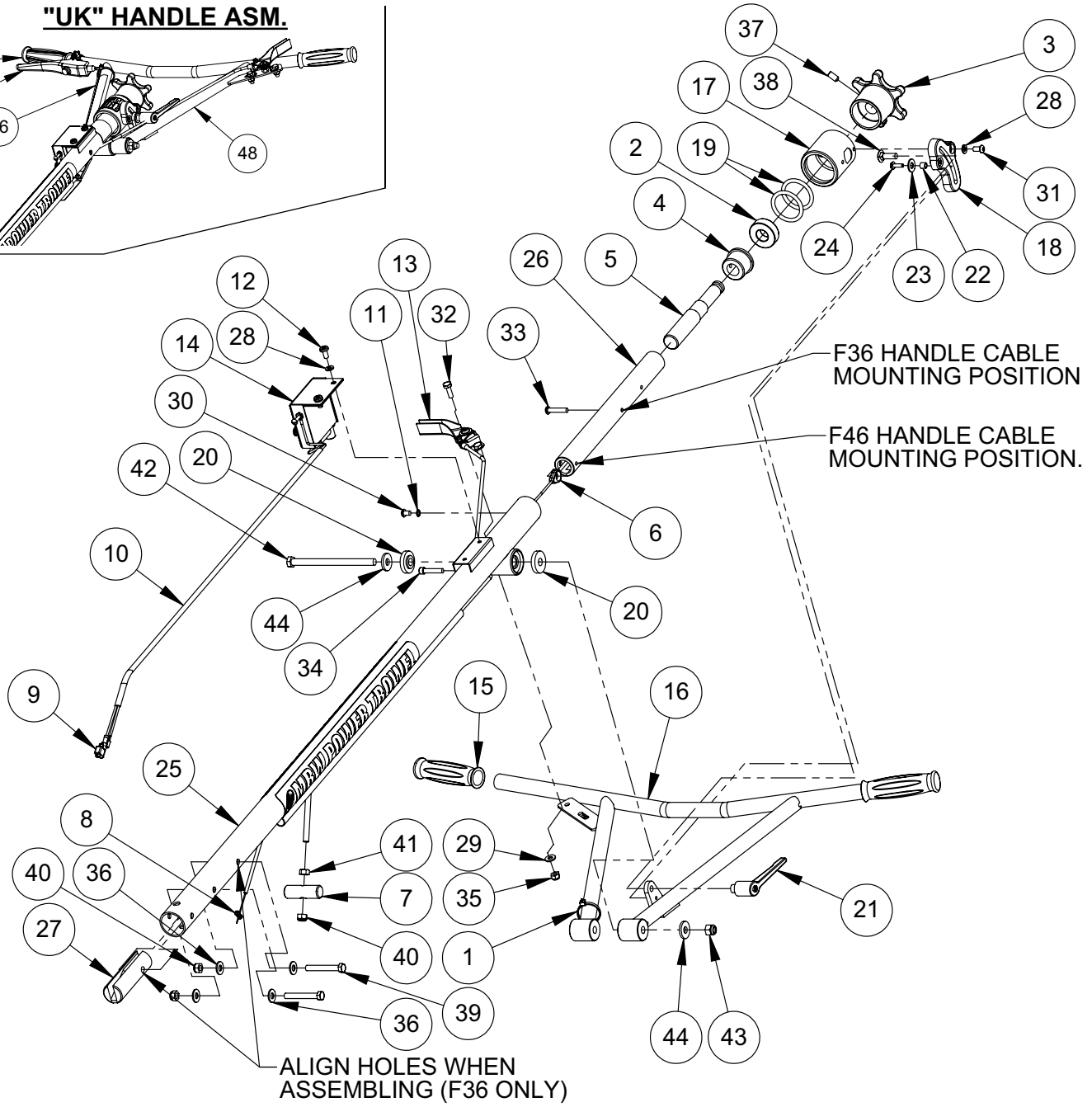
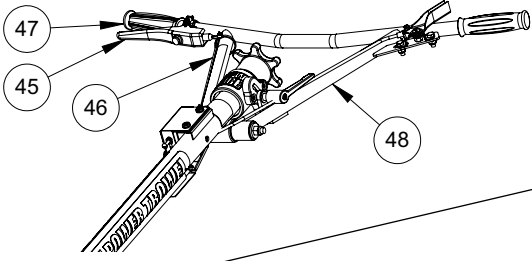

ALIGN HOLES WHEN ASSEMBLING (F36 ONLY)

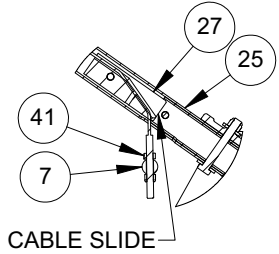
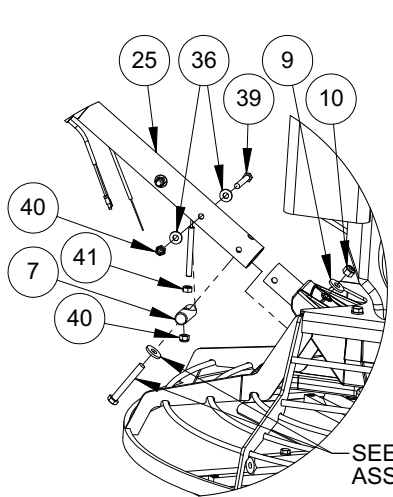

SEE GEAR BOX ASSEMBLY PAGE

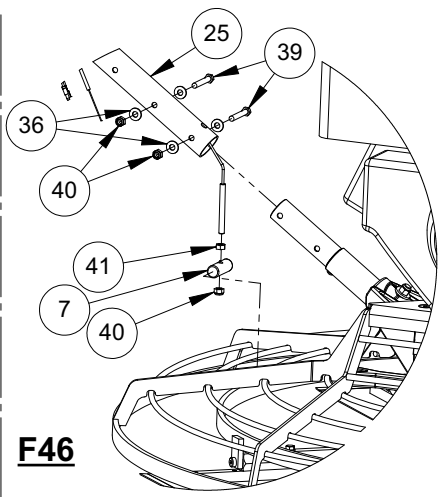

F36

F46

Low Vibration Handle

ITEM	PART NO.	DESCRIPTION	F36	F46
1.	01291	CABLE TIE	1	1
2.	01302	THRUST BEARING	1	1
3.	05358	KNOB	1	1
4.	05363	BEARING	1	1
5.	05365	TILT SHAFT	1	1
6.	05381	CABLE ASSEMBLY, (Includes items #40 & #41)	1	1
7.	05395	PIVOT PIN	1	1
8.	05477	SWIVEL	1	1
9.	07592	SPLICE TERMINAL	1	1
10.	07774	WIRE, SHORTING (63" long)	1	1
11.	15991	LOCK WASHER, 1/4" INTERNAL TOOTH	1	1
12.	16047	SELF TAP SCREW, 1/4-20 x 1/2	2	2
13.	20306	THROTTLE ASM	1	1
14.	21047	SWITCH ASSEMBLY, (Includes item #10)	1	1
15.	21109	HANDLE GRIP	2	2
16.	21173	HANDLE BAR	1	1
17.	21176	COLLAR, LOW VIBRATION HANDLE	1	1
18.	21594	BRACKET, LOW VIBRATION HANDLE	1	1
19.	21179	ISOLATION RING	2	2
20.	21180	ISOLATION BUSHING	2	2
21.	21181	HEIGHT ADJUSTMENT HANDLE	1	1
22.	21182	SPACER, ALUMINUM	1	1
23.	21183	WASHER, NYLON	1	1
24.	21184	HEX WASHER HEAD SCREW, #10-32 X 5/8 LG.	1	1
25.	21582	HANDLE CENTER TUBE	1	1
26.	21584	SHAFT, ADAPTER NUT	1	1
27.	21585	CABLE SLIDE	1	
28.	F04LW	LOCKWASHER, 1/4	4	4
29.	F04PW	WASHER, 1/4	2	2
30.	F042003BCS	BUTTON HEAD SCREW, 1/4-20 x 3/8	1	1
31.	F042004BCS	BUTTON HEAD SCREW, 1/4-20 x 1/2	2	2
32.	F042006HCS	HHCS, 1/4-20 x 3/4 ZP	2	2
33.	F042010BCS	BUTTON HEAD SCREW, 1/4-20 X 1-1/4 LG.	1	1
34.	F042010SCS	BUTTON HEAD SCREW, 1/4-20 X 1-1/4 LG.	1	1
35.	F0420ELN	ELASTIC LOCKNUT, 1/4-20	2	2
36.	F05SW	WASHER, 5/16 X 3/4 X 15 GA., ZP	4	4
37.	F051805SSS	SHSS, 5/16-18 x 5/8	1	1
38.	F051808CB	CARRIAGE BOLT, 5/16-18 X 1.0 ZP	1	1
39.	F051818HCS	HEX HEAD SCREW, 5/16-18 X 2-1/4, GR5, ZP	2	2
40.	F0518ELN	ELASTIC LOCKNUT, 5/16-18	3	3
41.	F0518HN	HEX NUT, 5/16-18	1	1
42.	F061644HCS	HHCS, 3/8-16 x 5-1/2 ZP	1	1
43.	F0616ELN	LOCKNUT, 3/8-16	1	1
44.	F06SW	WASHER, 3/8	2	2
		UK HANDLE ASSEMBLY		
45.	21071	HANDLE "DEADMAN", UK	1	1
46.	21076	WIRRE HARNESS, "DEADMAN" HANDLE, UK	1	1
47.	21110	HANDLE GRIP, "DEADMAN", UK	1	1
48.	21356	HANDLE BAR, UK	1	1
		REPLACEMENT PARTS		
	21580	F36 TROWELHANDLE ASSEMBLY (includes all above except item #8 & #9)		
	21581	F46 TROWEL HANDLE ASSEMBLY (includes all above except item #8 & #9)		
	19587	THROTTLE AND CABLE KIT (includes items #8 #16 #29 #23 & #35)		

"UK" HANDLE ASM.

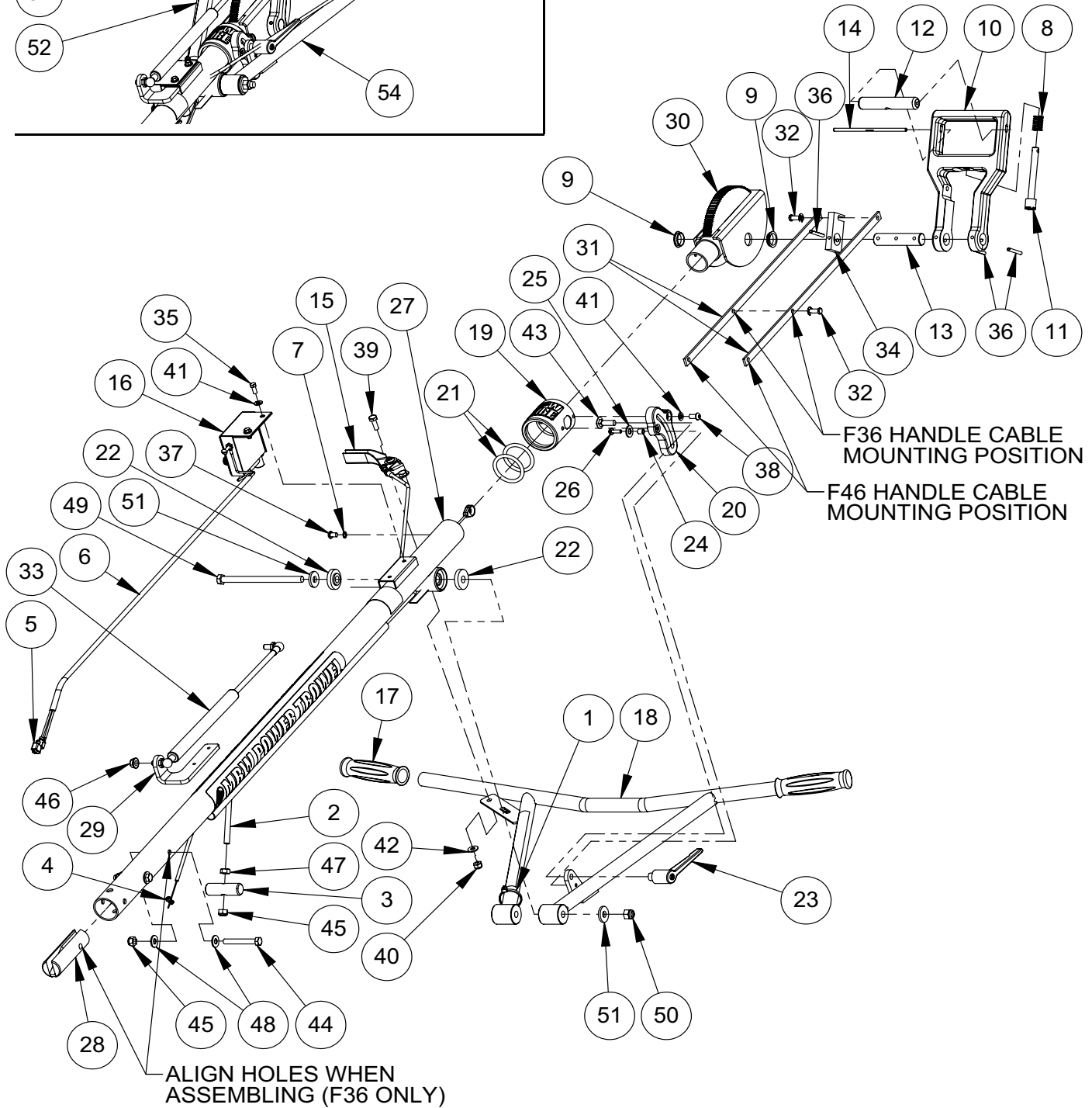
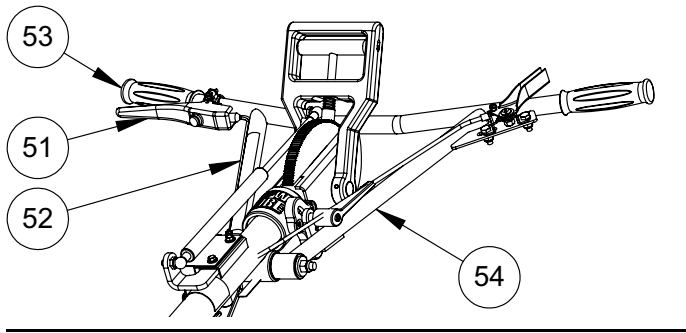

EZ Pitch Handle Assembly

ITEM	PART NO.	DESCRIPTION	F36	F46
1.	01291	CABLE TIE	1	1
2.	05381	CABLE ASSEMBLY, (Includes items #40 & #41)	1	1
3.	05395	PIVOT PIN	1	1
4.	05477	SWIVEL	1	1
5.	07592	SPLICE TERMINAL	1	1
6.	07774	SHORTING WIRE ASM	1	1
7.	15991	LOCK WASHER, 1/4" INTERNAL TOOTH	1	1
8.	16040	COMPRESSING SPRING	1	1
9.	16078	CLIP BEARING	2	2
10.	16081	LEVER ARM	1	1
11.	16083	LOCK DOG	1	1
12.	16084	TRIGGER PULL	1	1
13.	16086	SHAFT, ACTIVATING	1	1
14.	16099	DOWEL PIN, 3/16 x 5	1	1
15.	20306	THROTTLE ASM	1	1
16.	21047	SAFETY SWITCH ASSEMBLY (Includes item #6)	1	1
17.	21109	GRIP	2	2
18.	21173	HANDLE BAR	1	1
19.	21176	COLLAR, LOW VIBRATION HANDLE	1	1
20.	21594	BRACKET, LOW VIBRATION HANDLE	1	1
21.	21179	ISOLATION RING	2	2
22.	21180	ISOLATION BUSHING	2	2
23.	21181	HEIGHT ADJUSTMENT HANDLE	1	1
24.	21182	SPACER, ALUMINUM	1	1
25.	21183	WASHER, NYLON	1	1
26.	21184	HEX WASHER HEAD SCREW, #10-32 X 5/8 LG.	1	1
27.	21582	HANDLE CENTER TUBE	1	1
28.	21585	CABLE SLIDE	1	
29.	21712	STRUT MOUNT	1	1
30.	21713	GEAR ASSEMBLY, WELDED	1	1
31.	21716	HANDLE LINK	2	2
32.	21717	CLEVIS PIN, 1/4" X 5/8"	2	2
33.	21718	GAS SPRING	1	1
34.	21724	LEVER, EZ PITCH	1	1
35.	21725	HEX HEAD SCREW SCREW, #12-34 x 1/2	2	2
36.	F0312SP	SPIROL PIN, 3/16 x 1-1/2	3	3
37.	F042003BCS	BUTTON HEAD SCREW, 1/4-20 x 3/8 ZP	1	1
38.	F042004BCS	BUTTOM HEAD SCREW, 1/4-20 x 1/2	2	2
39.	F042006HCS	HEX HEAD SCREW, 1/4-20 x 3/4 GR5 ZP	2	2
40.	F0420ELN	NYLOC LOCKNUT, 1/4-20	2	2
41.	F04LW	LOCKWASHER, 1/4	4	4
42.	F04PW	WASHER, 1/4	2	2
43.	F051808CB	CARRIAGE BOLT, 5/16-18 X 1.0	1	1
44.	F051818HCS	HEX HEAD SCREW. 5/16-18 X 2-1/4 GR 5 ZP	2	2
45.	F0518ELN	NYLOC LOCKNUT, 5/16-18	3	3
46.	F0518FN	FLANGE LOCK NUT, 5/16-18	1	1
47.	F0518HN	HEX NUT, 5/16-18	1	1
48.	F05SW	WASHER, 5/16	4	4
49.	F061644HCS	HHCS, 3/8-16 x 5-1/2 GR5 ZP	1	1
50.	F0616ELN	NYLOC LOCKNUT, 3/8	1	1
51.	F06SW	WASHER, 3/8	2	2
		UK HANDLE ASSEMBLY:		
52.	21071	HANDLE "DEADMAN", UK	1	1
53.	21076	WIRRE HARNESS, "DEADMAN" HANDLE, UK	1	1
54.	21110	HANDLE GRIP, "DEADMAN", UK	1	1
55.	21356	HANDLE BAR, UK	1	1
		REPLACEMENT PARTS:		
	21723	F36 TROWELHANDLE ASSEMBLY (includes all above except item #4 & #5)		
	21722	F46 TROWEL HANDLE ASSEMBLY (includes all above except item #4 & #5)		
	19587	THROTTLE AND CABLE KIT (includes items #4 #15 #39 #40 & #42)		