



# Operating and Maintenance Manual



Low-level Powered Access  
a JLG company

[www.powertowers.com](http://www.powertowers.com)

**CONTENTS**

---

<b>Introduction</b> .....	2
<b>Operating Specifications</b> .....	3
<b>Working Envelope Diagram</b> .....	3
<b>Do's and Don'ts</b> .....	4
<b>Primary Components</b> .....	5
<b>Operating Procedures (Incl. Emergency Operation)</b> .....	6 - 8
<b>Maintenance Procedures</b> .....	9 - 12
<b>Castor Maintenance &amp; Safety</b> .....	13-14
<b>Storage</b> .....	15
<b>Key Spare Parts</b> .....	16-17
<b>Electric Circuit Diagram</b> .....	18
<b>Hydraulic Circuit Diagram</b> .....	19
<b>Warranty Terms</b> .....	20

**INTRODUCTION**

---

The Power Tower (referred to as “the machine” in this manual) is designed to be a simple, quick and safe powered alternative to a portable scaffold tower for construction site and maintenance applications.

The machine is suitable for any application provided it is used within its specified operating parameters. If used for applications such as sand blasting, welding, paint spraying or with any other hazardous materials, measures must be taken to ensure the machine does not become damaged in any way which may impair safety or reliability. Additional protection for the operator may be required in some cases, which is the responsibility of the operator.

The purpose of this manual is to provide essential basic information required to operate and maintain the machine.

This is not a workshop manual. Please contact the manufacturer or their agent for specific maintenance information if in doubt.

The Health and Safety of the operator or maintenance technician is the responsibility of the individual and/or their employer and not Power Towers Ltd.

## OPERATING SPECIFICATIONS

### Working Dimensions

Maximum Working Height	5.10 m
Maximum Platform Height	3.10 m
Platform Dimensions	1.52 x 0.75 m
Working Footprint	1.62 x 0.78 m
Safe Working Load	250 kgs
No. Persons	1
Maximum Manual Force	200 n
Max. Gradient for Operation	0°
Max. Wind Force	0 MPH Indoor Only
Manual Push Force on Level Ground	9 kgs
Maximum Total Weight Inc Payload	592kgs
Maximum Castor Point Load	2.9 KN

### Closed Dimensions

Length	1.62 m
Width	0.78 m
Height	1.85 m
Weight	342 kgs

### Power Source

Standard 12v DC Electric Motor IP55  
 Or 240v AC Electric Motor 13A Supply  
 Or 110v AC Electric Motor 16A Supply  
 Battery 12v 105A Traction Deep Cycle

### Battery Charger Specification

Input Voltage	90-265v A.C.
Frequency	45-65 Hz
Output	12v DC, 7A

**Emission EN 55014N, EN 61000 – 3 – 2**

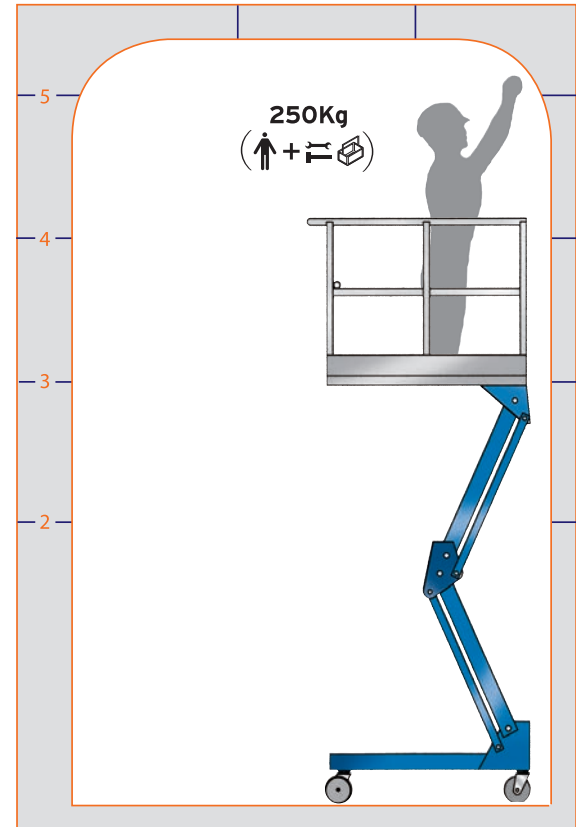

### DO'S

1. Read, understand and adhere to the instructions on the machine and in the Instruction Guide or Operating Manual
2. Ensure pre-operation checks and operations are carried out in the manner described
3. Use only on hard, level surfaces able to support the weight of the machine (e.g. concrete floor, tiled floor, hard wood floor)
4. Use the machine internally only
5. Ensure operator is fit and does not suffer from a fear of heights
6. Ensure the machine is correctly positioned with castor brakes on
7. Reassemble any removable guardrail sections (if applicable)
8. Ensure guardrail gate is closed and latched before elevation
9. Ensure work area around the machine is cordoned off from pedestrians and other traffic
10. Ensure operator is wearing the correct safety equipment
11. Ensure the platform is correctly positioned so as not to come into contact with fixed or moving objects
12. Ensure that the safe working load is evenly distributed on the platform

### DON'TS

1. Never exceed the safe working load 250kg (1 person plus tools)
2. Never use the machine on sloping or uneven ground
3. Never use the machine as a goods lift or crane
4. Never exceed horizontal forces; never use in wind (maximum horizontal force 200N)
5. Never use in the vicinity of live conductors
6. Never try to move the machine on its castors when elevated
7. Never extend the height of the platform by using boxes, steps ladders etc
8. Never modify the machine in any way without the full approval of the manufacturer
9. Never attempt to enter or exit the platform unless it is fully lowered
10. Never operate the machine outdoors or anywhere it may be affected by wind
11. Never lift heavy objects on the machine without the use of the correct lifting equipment
12. Never use the machine in an explosive environment
13. Never use the machine if you are fatigued or under the influence of drugs or alcohol
14. Never use the machine inappropriately or for horseplay
15. Never use the machine if suffering from poor health or using medication which may impair safe operation
16. Never use the machine if vision is impaired by bright lighting
17. Never use the machine on sloping surfaces without the use of a safe method
18. Never push or pull objects with the platform

PRIMARY COMPONENT LOCATIONS



## OPERATING PROCEDURES

It is essential to be familiar with the correct operating procedures. The operator must have adequate training for this type of platform.

The machine is fitted with a safety harness point as standard. It is recommended that if the operator chooses to wear a safety harness, an approved 'fall restraint' type harness should be worn.

Operating procedures are divided into three key areas:

1. Pre-operation checks. What to do before operating the machine.
2. Normal operation. How to use the machine safely.
3. Emergency Operation. How to lower the machine without power or in the event of operator incapacity.



It is the owners and/or the users responsibility to ensure that the machine is maintained and operated in accordance with the operation and maintenance procedures contained within this manual.



A. Powerpack Emergency Lowering Valve (undercover)

B. Cylinder Emergency Lowering Valve

**PRE-OPERATION CHECKS**

1. Ensure there are no obvious signs of mechanical damage to the handrails, platform, lifting structure or chassis. Ensure the gate self closes automatically and the latch locks correctly.
2. Check castors and wheels rotate freely and are undamaged.
3. Check castor wheel and castor fixings.
4. Check emergency lowering is functioning correctly (refer to procedure on p.8).
5. Ensure the battery (where applicable) is fully charged, referring to the battery condition meter.
6. Check the raise and lower functions work from both the platform and ground controls.
7. Ensure the hydraulic oil level is at the correct level. Do not overfill.
8. Check there are no hydraulic oil leaks and that all hydraulic connections are tight.
9. Cordon off area around machine in accordance with guidelines.

**Do not use the machine if any of the above items are found to be faulty**  
**NORMAL OPERATION**

**Only use the machine internally, on hard level surfaces. Ensure a person is available at ground level to assist in case of emergency.**

1. Position machine under application. Refer to working envelope diagram if necessary.
2. Apply both castor brakes.
3. Check spirit level to ensure machine is level.
4. Ensure the battery isolator switch is on and the emergency stop buttons are released.
5. Turn key switch to 'Platform' controls. LED should illuminate to indicate 'Power on'.
6. Enter platform via step and gate and ensure the gate is closed and latched correctly when in platform. Do not elevate if not.
7. Check there are no overhead obstructions; depress white button to elevate and black button to lower.
8. In case of uncontrolled platform elevation or descent, depress red emergency stop button.



**The user shall obtain the guidance and approval of the manufacturer in the event of any special working condition or methods outside those specified by the manufacturer**



## EMERGENCY LOWERING OPERATION

### In case of platform control failure or operator incapacity:

#### To lower the platform:

1. Switch key switch to 'Emergency' position and left hand LED will illuminate.
2. Depress black button to fully lower the platform, from the ground control position.
3. **Keep clear of descending structure.**



#### In the event of complete power failure or machine fault, use emergency lowering valves as follows:

1. Remove powerpack cover.
2. Locate red knob on powerpack valve **A**. Pull and twist red knob so valve remains open. Locate red knob on cylinder valve **B**. **Keeping clear of descending structure**, push red knob on cylinder valve. Allow the platform to lower to a position where the operator can exit the platform safely. Release red knob on cylinder at any time to stop descent.
3. **Keep clear of descending structure.**

## BATTERY CHARGING

The battery charger is located under the powerpack cover as indicated on the Primary Component Locations diagram. (p.5).

Under the cover is a loose mains supply lead for the battery charger **C**. The lead can have fitted either a 110v or 230v ac plug. The charger input lead is hard-wired into the battery charger. The battery charger is fully voltage sensitive, so there is no voltage selection to do when connecting to different voltages. Ensure the battery isolator is switched on when charging. Plug into an available power supply and ensure the green LED (top of charger)

illuminates **D**. The adjacent amber LED has three modes. 1. Rapid flash, indicates maximum charge rate. (Note, when switching charger on, the amber light must rapid flash. If not, there is a fault, check fuse\* and connections). 2. Slow pulse, indicates slower charging. 3. Continuous illumination indicates float charge. Both lights go "off" when fully charged.

The battery charger can be connected to the mains supply at any time or left for extended periods. The machine can be operated when the charger is connected, although this is not recommended. All mains supply should be protected with a suitable RCD. Additionally a "Curtis" battery condition meter is provided which does give an approximate indication of battery charge level.

**\*Note: The charger is fitted with a 15A automotive spade fuse (blue). If the fuse has failed, the indicator lights will still operate. The fuse may have failed if the battery is heavily discharged and the motor is run when the charger is switched on. In such an event, the fuse is simple to replace; ensure battery isolator is switched off and that the mains supply is disconnected before attempting to check or change fuse.**

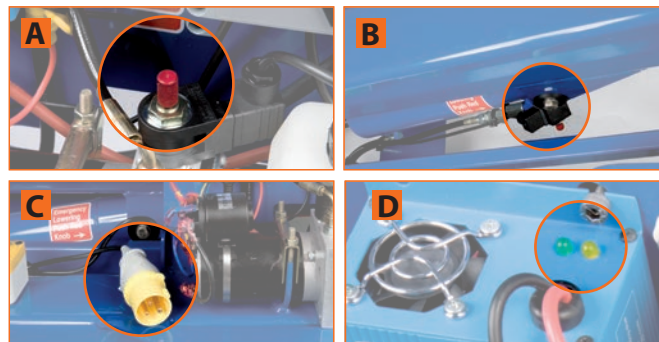



Please note that whilst the machine is extremely simple to maintain, all work must be carried out by a competent person.

**When removing battery cover or powerpack cover for maintenance purposes, first switch off battery isolator. Use appropriate safety/personal protective equipment where necessary.**

## DAILY MAINTENANCE

---

1. **Check battery electrolyte level:**  
Remove battery cover and battery caps. Ensure the electrolyte covers the plates by no more than 1mm – 2mm. Replenish with distilled water to this level, only if the electrolyte level is below the top of the plates.
2. **Check hydraulic oil level:**  
Ensure the tank is not overfilled. The level must only be checked when the machine is in the transport position.



The correct level in this condition is approximately 1/3 from the base of the tank, as indicated by the line.

3. Ensure there is no obvious mechanical damage to the handrails, entrance gate, step, boom structure or chassis. Also check the castors and wheels are undamaged and rotate freely. Check all locking bolts are tight.
4. Check hydraulic hoses and connections are tight and undamaged.

5. Check the spirit level to ensure it is clearly legible and undamaged.

## WEEKLY MAINTENANCE

---

1. Check battery terminal connections are tight.

## MONTHLY MAINTENANCE

---

1. Grease all pivots as indicated by the greasing points photograph on page 11. It will be necessary to remove the knuckle cover to access three of the grease nipples. Use a lithium based anti seize grease.

## GREASE POINT LOCATIONS

---

Refer to page 11.

## KEY FIXINGS TABLE

It is the platform owner/operators responsibility to maintain the machine in good safe working condition.

Key Fixing Torque Table			
Location	Fixing Size	Torque	Thread Lock Adhesive
Handrail Hoop	M8 (NYLOC)	2 –3 Nm	No
Handrail Feet	M12 (NYLOC)	30 Nm	No
Pivot Pin Securing Screw *	M6 Socket cap	0.5 Nm	Loctite 648
Pivot Pin Washer Screw *	M12	40-50 Nm	Loctite 648
Swivel Castor Fixing	3/4 UNC (NYLOC)	120 Nm	No
Castor Axle	M12	40 Nm	No
Wheel Fixing Screw	M10	30 Nm	Loctite 648

**When replacing wheels, refit with new Wedgeloc screw and countersunk washer supplied with wheel.**

**\*When being replaced these fixings must be cleaned and re-assembled with a thread lock adhesive or new locknuts where appropriate.**

## HYDRAULIC OIL

The hydraulic oil must be replaced on an annual basis. If the oil is not replaced, premature wear and failure of components will occur.

To drain the oil from the tank, fully elevate the boom and then disconnect the 'P' connection at the pump manifold. Hold the open end in a suitable container of hydraulic oil. It is recommended the container is capable of holding around 5 litres and should ideally

already contain approximately 2 litres of hydraulic oil, in to which the open pipe should be placed, this will prevent splashing of the oil. Operate the down button until the boom has returned to the transport position. Refit the hydraulic pipe and refill the tank with no more than 1-2 litres of oil. Overfilling the tank will cause spillage. Refill with grade 32 mineral oil.

Greasing Points

**Greasing Pivots – (refer to photograph opposite)**

All pivots are fitted with corrosion proof pivot pins, and polymer self-lubricating bushes, except for the cylinder rod end, which has a standard rod end bearing.

We recommend that all pivots are greased on a monthly basis with an anti-seize grease. Failure to do so will nullify the structural warranty.

**Wheels and Castors**

It is absolutely essential that the wheels and castors are maintained in good condition at all times, for two reasons:

The first is that they act as the stabilisers, and the only point of contact with the ground; any failure could result in a serious accident. Secondly, if the bearings become tight, then it will make the machine difficult to manoeuvre.

A measure of horizontal push force can simply be made to determine the condition of the wheel bearings. On a flat smooth surface the machine should move with a force of 9 – 10 kgs at the mid guard rail height.

This force varies upon the surface and gradient, but the above is the recognised method of measurement, in accordance with HSE guidelines.

**For full castor safety and maintenance procedures please refer to page 13**



Grease Nipple

**MAINTENANCE FREQUENCY TABLE**

The machine must have a thorough (**LOLER**) examination by a competent person at six monthly intervals.

Item	Daily	Monthly	6 Months	12 Months
Batteries/Connections	●			
Oil Level	●			
Visual Inspection	●			
Spirit Level	●			
Castors	●			
Grease All Pivots		●		
Thorough Examination			●	
Change Hydraulic Oil				●

**THOROUGH EXAMINATION** must include checking:

All electrical connections, including battery.  
 All hydraulic connections and cylinder for leaks.  
 All connections are secure to powerpack.  
 Handrails are undamaged and secure.  
 Operation of gate latch.  
 Platform tray condition.  
 Condition and security of platform entrance step.  
 Boom pivots and fixings are secure, including link bar under knuckle cover.

Mechanical condition of lifting structure and chassis.  
 Swivel castor condition and security.  
 Axle and wheels for condition and security.  
 Condition and operation of spirit level.  
 Component and battery covers for condition.  
 Condition of all labelling.  
 Carry out a full operation check and load test.  
 Key fixings for tightness (refer to table on page 10).

## CASTOR SAFETY & MAINTENANCE

### Important.

These instructions apply to all machines BEFORE serial no. 27382915A.

In order to ensure the castors are maintained in serviceable and safe condition, regular inspection is required, especially where arduous conditions are known to be involved or there is a suspicion of misuse or abuse. The other key element to ensure is in safe serviceable condition, is the castor fixing bolt, the condition of which can usually be determined from the condition of the castor bracket.

The castor is highly rated for the application so if visible distortion is evident a significant impact will have occurred and under these conditions the castor and fixing must be replaced.

Below are some examples of typical signs of impact which would require castor and fixing replacement.



Side impact and foot pedal distortion as a result of a significant side impact.



Foot pedal distortion as a result of a significant frontal impact; it is likely the top plate and bearing will be distorted as well.



Top mounting plate distortion as a result of a single significant impact or multiple lower level impacts. **Even if the rest of the castor is in good condition, it must be replaced.**

It may be thought feasible to repair the castor in a number of these instances, but serious structural damage will have occurred to the head bearing and castor assembly as well as possibly damage to the main mounting bolt.

When inspecting a castor in order to determine its serviceability, pay particular attention to the head swivel bearing (compare to a new one if possible) and the boss/rivet which goes through the centre of the swivel bearing and which clamps the assembly together.



Castor mounting bolt Swivel bearing head should feel free to rotate and not loose

If the castor is in sound condition, free from distortion then it may be adequate to only replace the main fixing bolt with one of a higher tensile strength, along with a spacer washer that enables a higher bolting torque to be applied. This will improve the reliability of the fix, but will not increase the strength of the castor assembly. The new fixing nut and bolt are to be re-torqued to 80Nm.

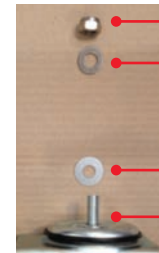

M12 nyloc nut torque to 80Nm.  
M12 standard washer.  
Special thin spacer washer on top of swivel bearing of castor  
M12X16 10.9 bolt

In order to replace the fixing bolt, the wheel axle bolt, half nut and star washer will first need to be removed, along with the central bushing tube and M12 end washers. This enables the wheel to be removed so that the castor fixing bolt can be replaced.

When refitting the wheel, the axle bolt, half nut and star washer, must be replaced with OEM specification new parts and re-torqued to 40Nm. (Pic A) Ensure the axle tube and assembly is lightly greased to ensure a smooth action when operating the foot brake.



Pic A.

**Power Towers Limited strongly recommends replacing any castor assembly that is over 3 years old with a new one.**

## Important.

These instructions apply to all machines FROM serial no. 27382915A and onwards.

### CASTOR SAFETY & MAINTENANCE

In order to ensure the castors are maintained in serviceable and safe condition, regular inspection is required, especially where arduous conditions are known to be involved or there is a suspicion of misuse or abuse. The other key element to ensure is in safe serviceable condition, is the castor fixing bolt, the condition of which can usually be determined from the condition of the castor bracket.

The castor is highly rated for the application so if visible distortion is evident a significant impact will have occurred and under these conditions the castor and fixing must be replaced.

Below are some examples of typical signs of impact which would require castor and fixing replacement.



Foot pedal distortion as a result of a significant impact; it is likely the top plate and bearing will be distorted as well.



**It may be thought feasible to repair the castor in a number of these instances, but serious structural damage will have occurred to the head bearing and castor assembly as well as possibly damage to the main mounting bolt.**



Mounting plate distortion as a result of a single significant impact or multiple lower level impacts. **Even if the rest of the castor is in good condition, it must be replaced.**

When inspecting a castor in order to determine its serviceability, pay particular attention to the head swivel bearing (compare to a new one if possible) and the boss/rievet which goes through the centre of the swivel bearing and which clamps the assembly together.

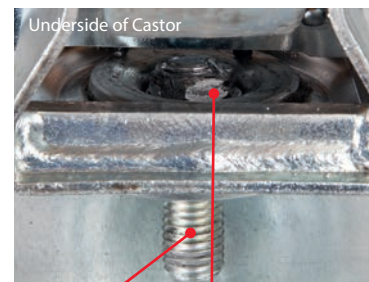

Castor mounting bolt

Swivel bearing head should feel free to rotate and not loose

**Castor Fixing Bolt (3/4 UNC):**

**Torque - 120 Nm**

**Castor Axle Bolt:**

**Torque - 40 Nm**

## STORAGE

---

If the machine is to be taken out of operation for a period longer than one month, the following precautions should be taken.

Ideally, the battery charger should be switched on. The charger has an inbuilt maintenance mode, and will maintain the battery in good condition indefinitely, although obviously the electrolyte level must still be checked periodically. If this is not practical, then the charger should be switched on once a week for half an hour. This is especially important in cold conditions.

All the pivots must be greased with anti-seize grease, and the hydraulic oil replaced (recommended after 3 months of non-use) as for the procedure in the maintenance procedures section.

If the storage period is for an undetermined period then it is advisable that the battery be removed and stored in a secure battery storage container. We would also advise that all external electrical and hydraulic connections be wax coated to prevent corrosion.



ELECTRICAL PARTS		Part No.
A	Emergency Stop Button (platform)	PT-E-003
B	Emergency Stop Button (chassis)	PT-E-004
C	Key Switch	PT-E-005
D	Push Button Head (white)	PT-E-006
E	Push Button Head (black)	PT-E-007
*	Contact Black NO	PT-E-008
*	Contact Black NC	PT-E-009
F	110v Plug	PT-E-010
G	110v Socket	PT-E-011
H	12/7 A Battery Charger	PT-E-001
I	12v 105A Traction Battery	PT-E-002
J	Battery Isolator	PT-E-014
HYDRAULIC PARTS		Part No.
K	12v DC Powerpack Complete	PT-H-051
*	Powerpack Valve Cartridge	PT-H-052
L	Cylinder	PT-H-053
*	Cylinder Valve Cartridge	PT-H-054
*	Cylinder Seal Kit	PT-H-055
*	Hose Kit Complete	PT-H-056
M	Powerpack Lower Valve Solenoid	PT-H-064
N	Cylinder Solenoid	PT-H-057
*	Hydraulic Filler Cap	PT-H-058

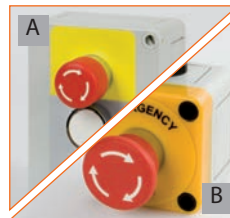

\* Item not shown here

## MECHANICAL &amp; MISCELLANEOUS PARTS

Part No.

A	Battery Cover	PT-M-104
B	Powerpack Cover	PT-M-105
C	Swivel Castor c/w fixing	PT-M-102-2
D	Wheel c/w fixing	PT-M-103
E	Guardrails Complete	PT-M-101
F	Wide Step Treadplate	PT-M-129 B
G	Spirit Level	PT-M-106
H	Cover Securing Knob	PT-M-107
I	Decal Set 1	PT-M-108
J	Decal Set 2	PT-M-109
K	Decal Set 3	PT-M-110
L	Decal Set 4	PT-M-111
*	Keys - Pair	PT-M-112

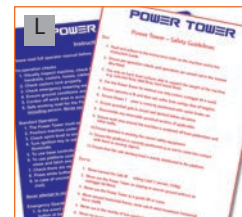
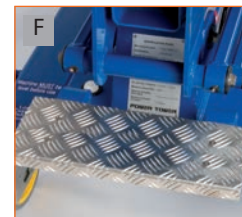
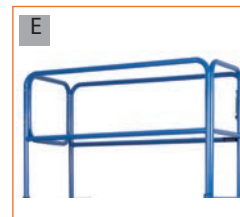
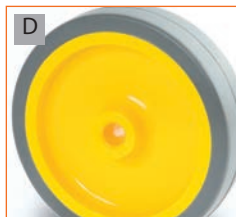

\* Item not shown here



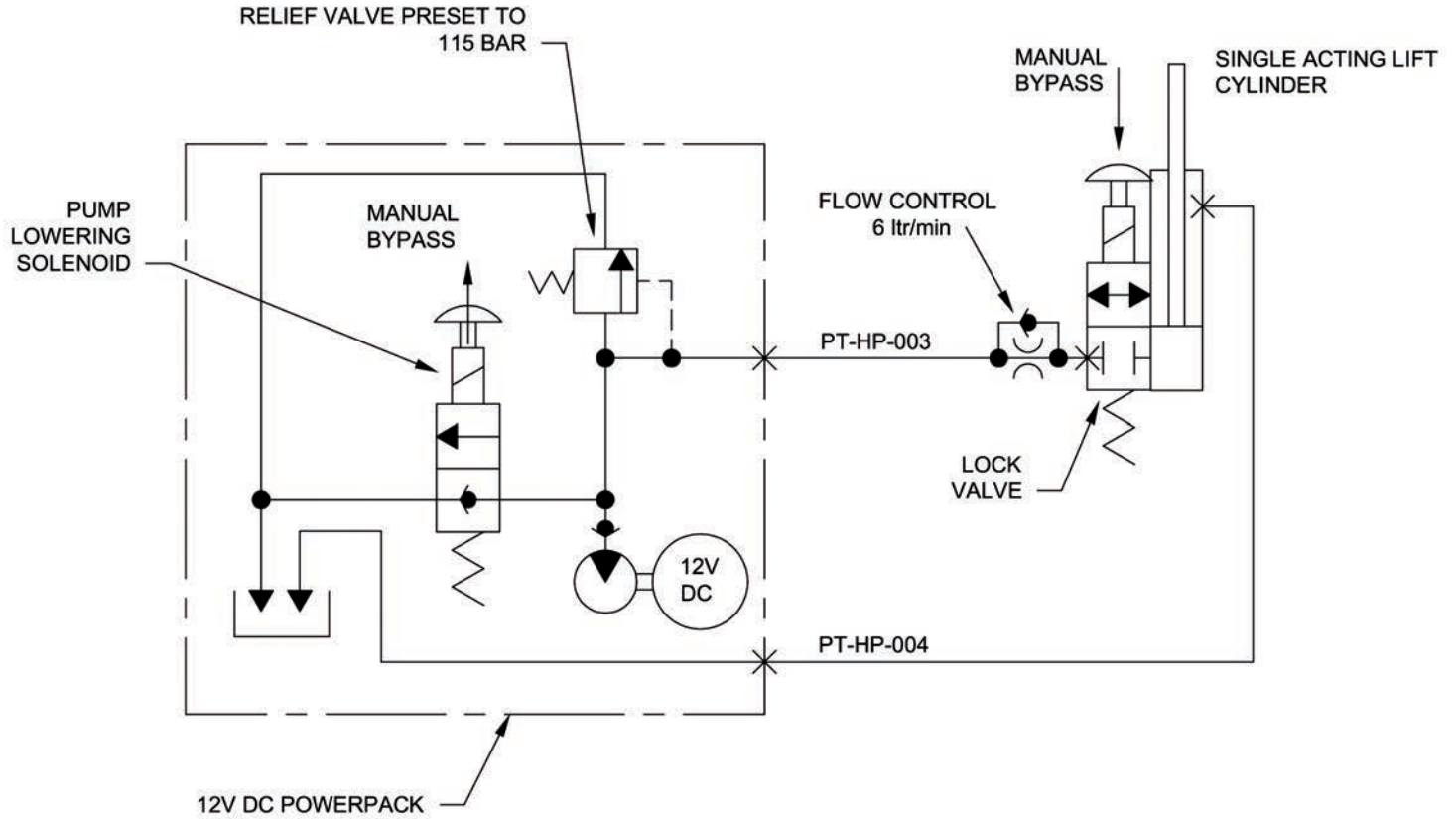

## WARRANTY

Your Power Tower (The Machine) is covered by a parts and components warranty as stated in the purchase terms and conditions (excluding battery and battery charger).

The Manufacturer, Power Towers Ltd (The Company), undertakes to replace or repair, free of charge, any defective part or component which the company considers to be due to faulty workmanship or material, within the warranty period, except for:

Defects arising from neglect, misuse or unauthorised modifications.

Damage caused by abuse, misuse, dropping or other similar damage caused by or as a result of failure to follow transportation, storage, installation, loading or operation instructions.

Alterations, additions or repairs carried out by persons other than the Manufacturer or their recognised distributors.

Transportation or shipment costs to and from the Manufacturer or their recognised agents, for repair or assessment against a warranty claim, on any machine or component.

Materials and/or labour costs to renew, repair or replace components due to fair wear and tear.

Faults arising from the use of non-standard or additional parts, or any consequential damage or wear caused by the fitting or use of such parts.

### **Important**

Warranty may at the sole discretion of the manufacturer, be voided if the scheduled service/inspections are not carried out in accordance with this manual.

The Manufacturer and/or their recognised agents, directors, employees or insurers will not be held liable for consequential or other damages, losses or expenses in connection with or by reason of or the inability to use the machine for any purpose.

### **Modifications**

If additional equipment or any third party work, modifications or alterations are to be carried out on the machine which will involve any welding, drilling or any form of cutting or distortion of materials, full written approval must be obtained from the Manufacturer prior to the work being carried out.









