

HILTI

TE 76 / TE 76 P
TE 76-ATC
TE 76 P-ATC

Bedienungsanleitung

de

Operating instructions

en



CE

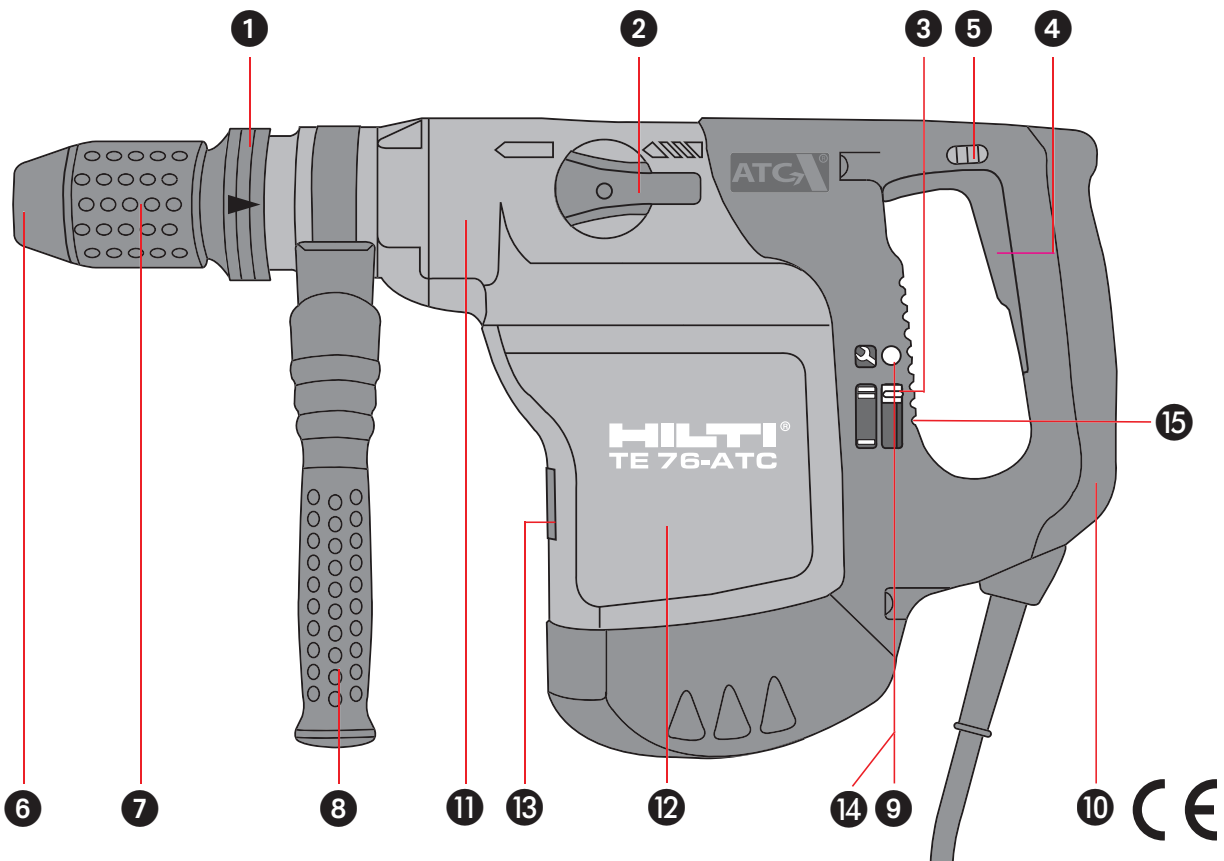
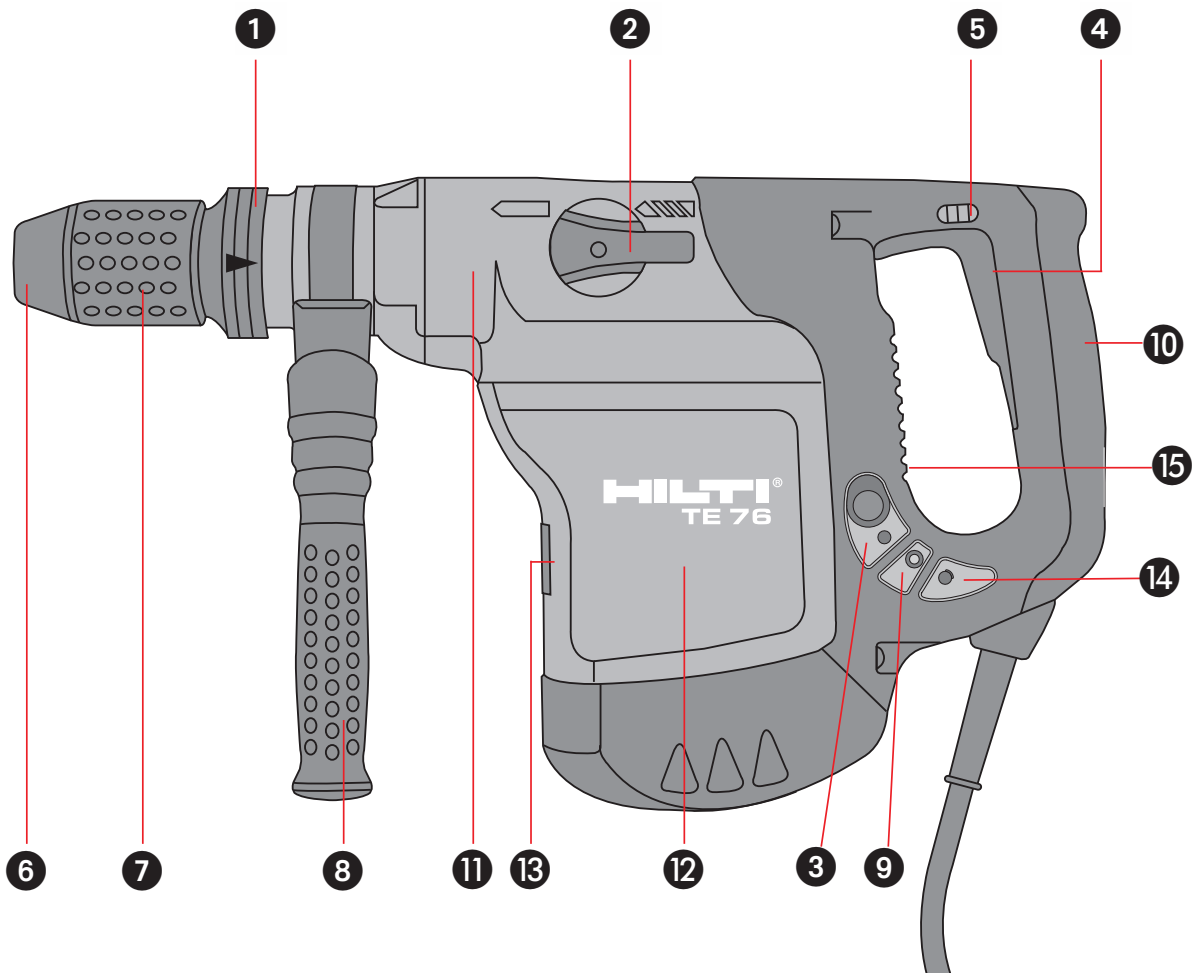

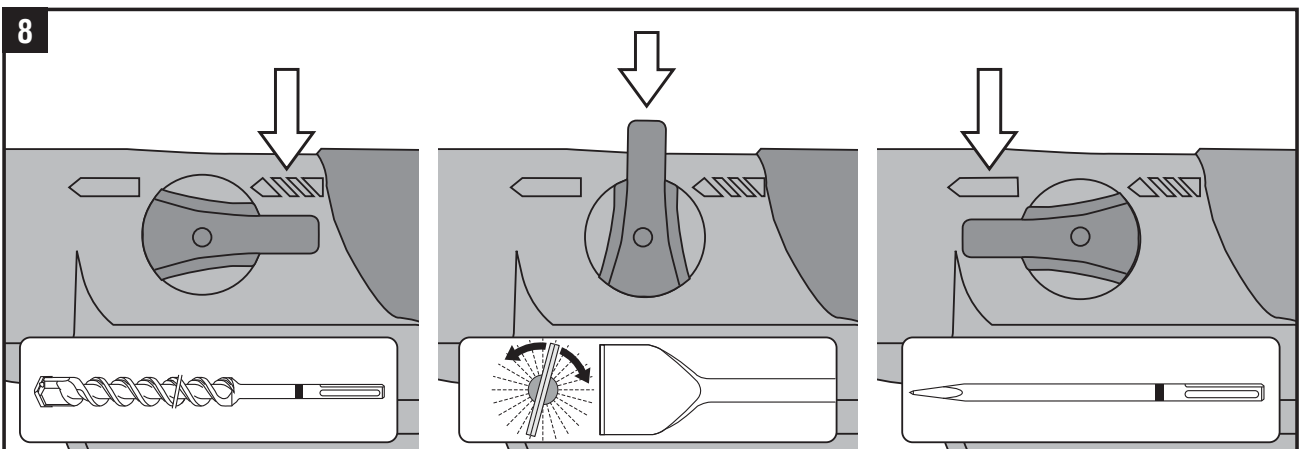
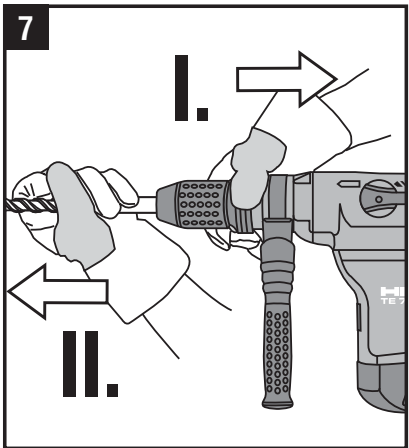
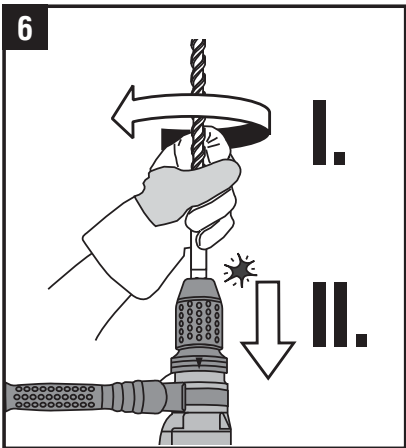
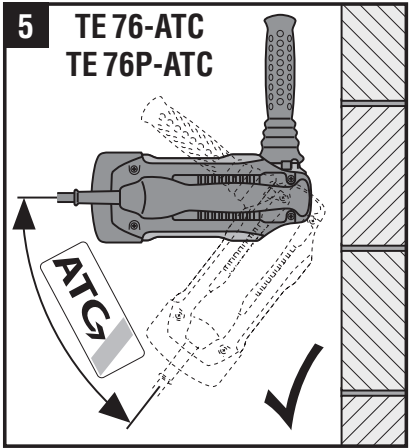
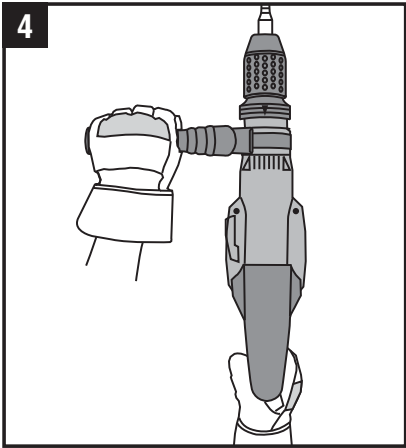
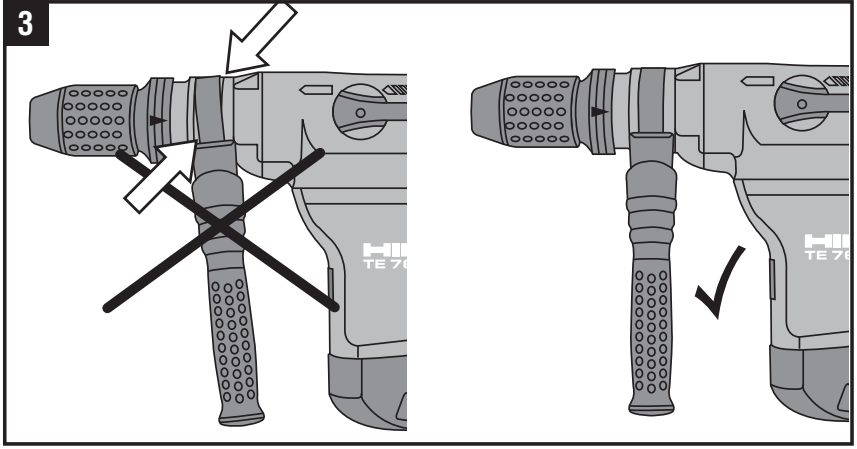
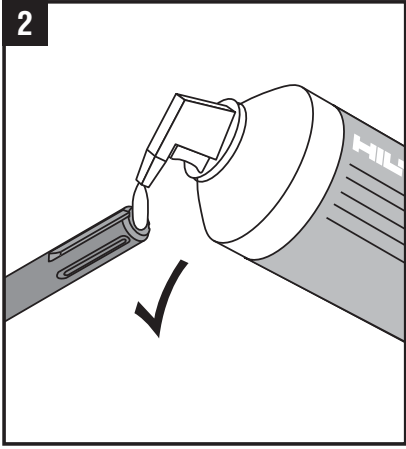

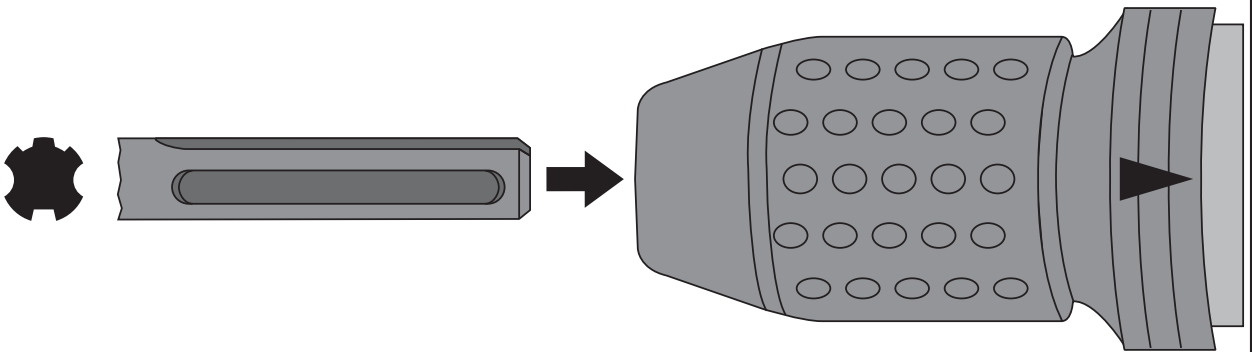
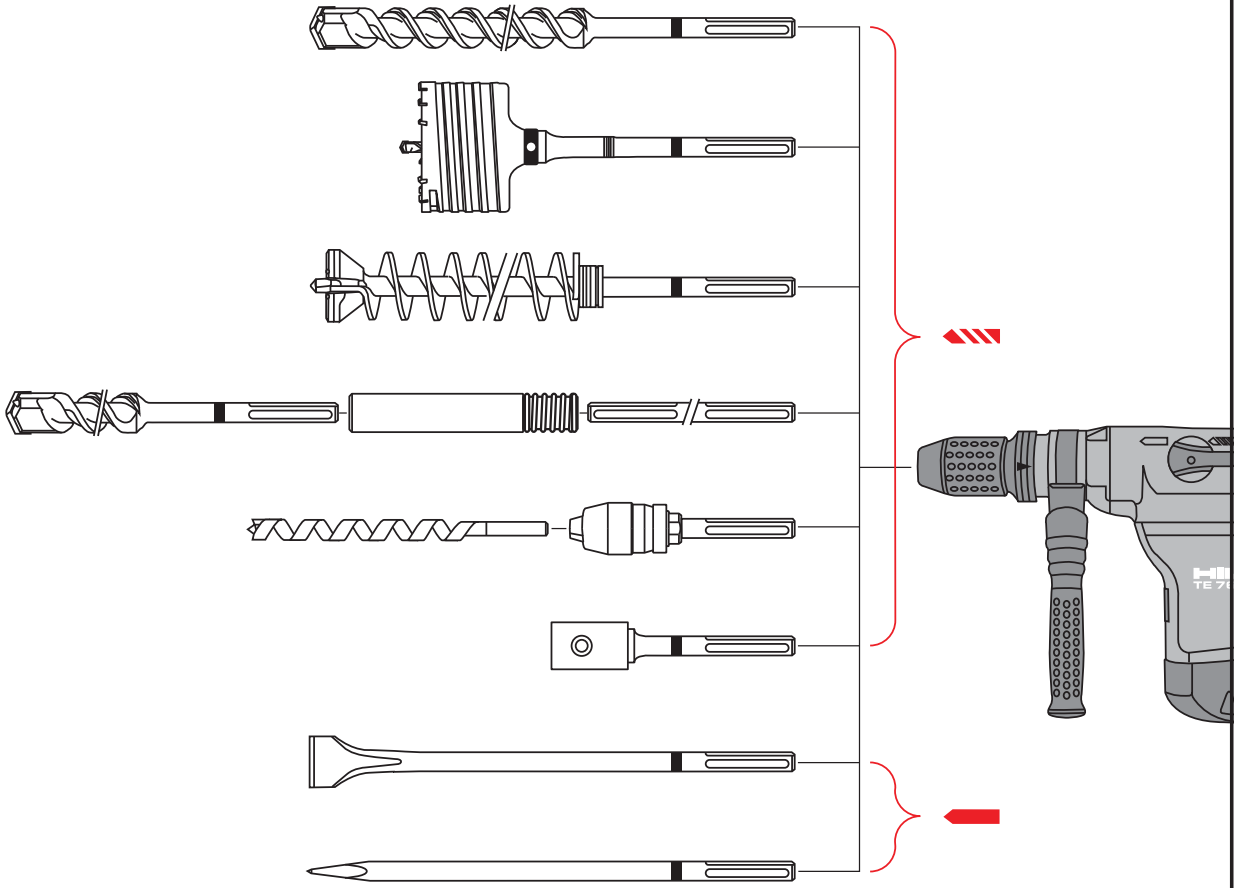

10

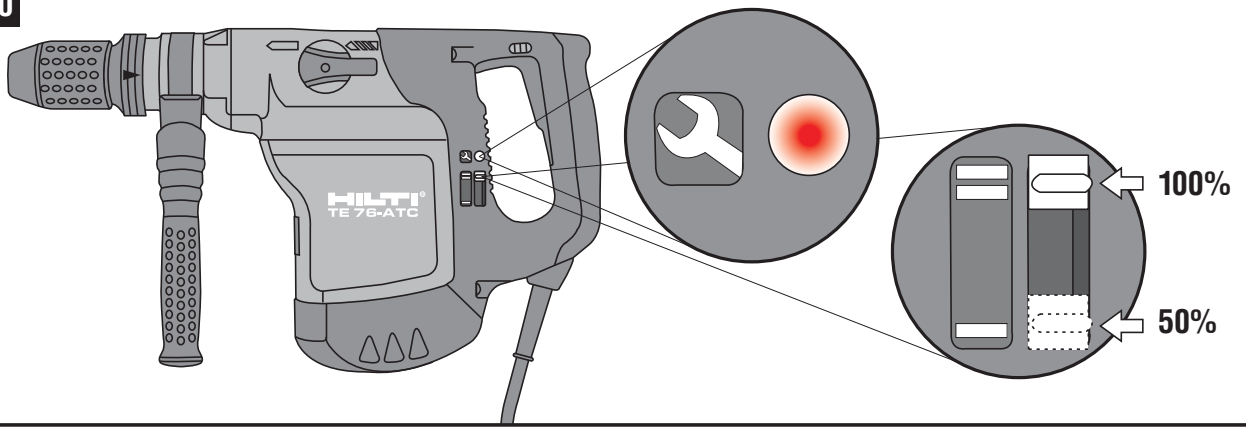

11

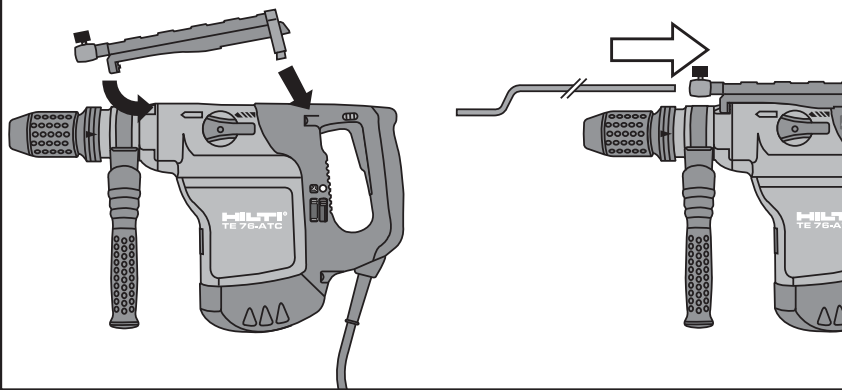

12

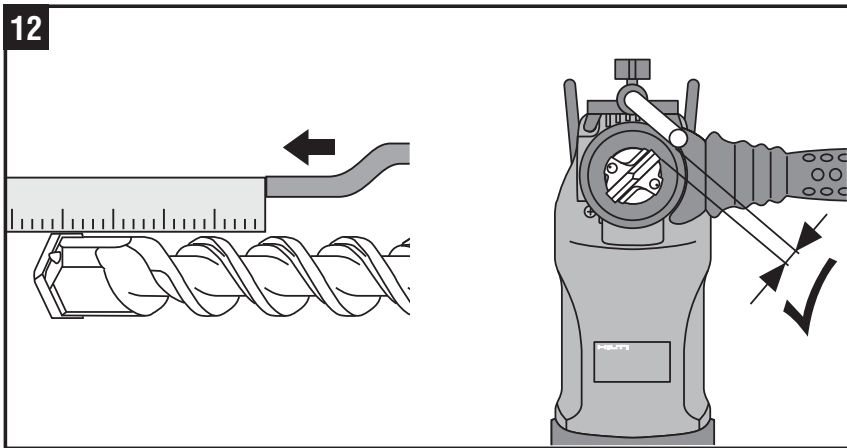

13

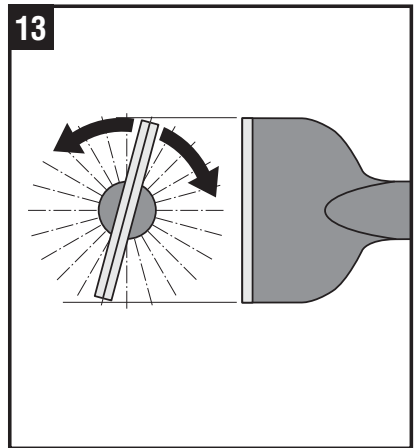

14

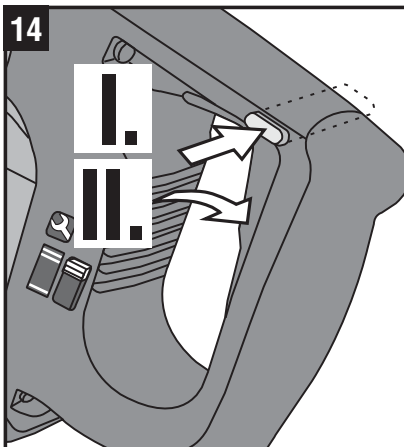

15

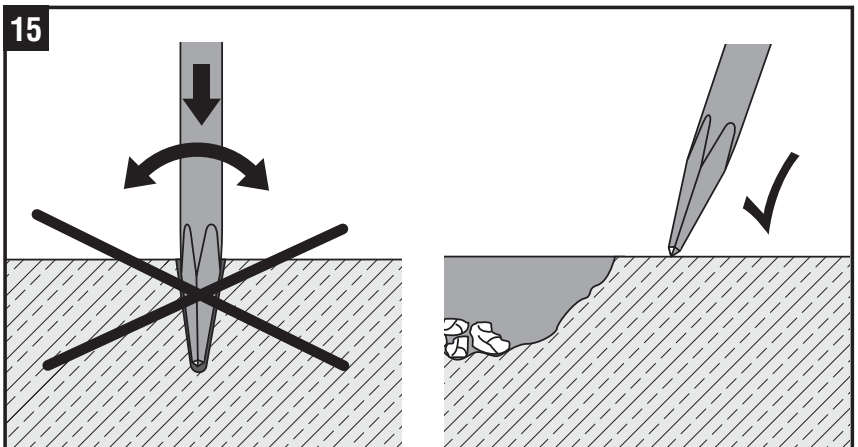

TE 76/TE 76P/TE 76-ATC/TE 76P-ATC combihammer

It is essential that the operating instructions are read before the tool is operated for the first time.

Always keep these operating instructions together with the tool.

Ensure that the operating instructions are with the tool when it is given to other persons.

Operating controls **1**

- 1 Chuck locking sleeve
- 2 Function selector switch
- 3 Power selector switch
- 4 Control switch
- 5 Switch lock for chiselling

Tool components **1**

- 6 Dust shield
- 7 Chuck
- 8 Side handle
- 9 Service indicator
- 10 Grip
- 11 Hammering mechanism / gearing
- 12 Motor
- 13 Type plate
- 14 Theft protection indicator
(option TE 76P / TE 76P-ATC)
- 15 Lock symbol

Contents	Page
1. General information	11
2. Description	11
3. Technical data	13
4. Safety precautions	14
5. Preparation for use	15
6. Operation	15
7. Insert tools and accessories	17
8. Care and maintenance	17
9. Manufacturer's warranty – tools	18
10. Disposal	18
11. Trouble shooting	19
12. EC-Declaration of conformity	19

1. General information

 In these operating instructions, this symbol indicates points of particular importance to safety. The instructions at these points must always be observed in order to avoid the risk of serious injury.

 Caution: high voltage

1 The numbers refer to the illustrations. The illustrations can be found on the fold-out cover pages. Keep these pages open while you read the operating instructions.

In these operating instructions, the power tool to which these operating instructions apply is referred to as “the tool”.

2. Description

The TE 76 / TE 76P / TE 76-ATC / TE 76P-ATC is an electrically powered rotary hammer and breaker with pneumatic hammering mechanism designed for professional use.

The following items are supplied: power tool, operating instructions, grease (50 ml), cleaning cloth, toolbox.

 **The following conditions must always be observed when the tool is in use:**

- The tool must be connected to an alternating current electric supply in compliance with the information given on the type plate.
- The tool is for hand-held use only.
- The tool must not be used in places where the surrounding conditions may present a risk of explosion.

Main features of the tool

Electrical protection class II (double insulated) 
 Active Torque Control TE76-ATC / TE76P-ATC
 (additional operator protection in drilling mode)
 Mechanical torque-limiting clutch
 No-load hammering absorption
 Grip and side handle with vibration absorption
 Quick-change chuck
 TE-Y insert tool system
 Infinitely variable speed, with electronic regulation
 independent of load
 Selector switch for full power (II) and half power (I)
 Drilling and chiselling modes
 Control switch lockable in chiselling mode
 24-way chisel position adjustment
 Gearing and hammering mechanism with oil lubrication
 Automatic cut-out carbon brushes
 Service indicator with light signal
 Pivotal side handle
 Depth gauge attachment (optional)

Theft protection system (option TE 76P / TE 76P-ATC)

The tool may be equipped with the optional theft protection system. If the tool is equipped with this feature, it can be activated and made ready for operation only by way of the corresponding activation key.

Right of technical changes reserved

The tool is designed for the following uses:

Use	Required insert tools	Working range
Drilling in concrete, masonry and natural stones	Drill bit with TE-Y connection end – Hammer drill bits – Breach bits – Percussion core bits	Drilling range in concrete 12– 40 mm dia. 40– 80 mm dia. 45–150 mm dia.
Chiselling in concrete, masonry and natural stone	Pointed, flat and shaped chisels with TE-Y connection ends	Surface finishing and breaches
Setting anchor	Setting tools with TE-Y connection ends	All Hilti anchors with TE-Y setting tools
Drilling in wood and metal	Chuck holder, item 263359 Keyless chuck, item 60208 Wood drill bits and metal drill bits with smooth or hex. shank	Wood drill bits, 10–32 mm dia. Metal drill bits, 10–20 mm dia.
Mixing non-flammable materials, e.g. grout	Chuck holder, item 263359 Keyless chuck, item 60208 Mixing tools with smooth or hex. shank	Mixing tools, 80–150 mm dia.

3. Technical data

TE 76 / TE 76-ATC						TE 76P / TE 76P-ATC					
Rated power	1300 W	1300 W	1300 W	1300 W	1300 W	1300 W	1400 W	1400 W	1400 W	1400 W	1400 W
Nominal voltage *	100 V	110 V	120 V	220 V	230 V	240 V	110 V	120 V	220 V	230 V	240 V
Nominal current input * 16 A	13 A	13 A	6.4 A	6.4 A	6.5 A	6.5 A	14.1 A	13.7 A	7.0 A	6.8 A	6.9 A
Frequency	50–60 Hz										
Weight as per EPTA-Procedure 01/2003	TE 76 / TE 76P						7.4 kg				
	TE 76-ATC / TE 76P-ATC						8.3 kg				
Dimensions (l×h×w)	TE 76 / TE 76P						497 x 261 x 115 mm				
	TE 76-ATC / TE 76P-ATC						510 x 288 x 115 mm				
Minimum distance between wall and hole drilled	38 mm										
Speed	II = 0–282 I = 0–200 r.p.m.										
Typical drilling performance in medium-hard B35 concrete	20 mm dia.: 360 mm/min 25 mm dia.: 290 mm/min 32 mm dia.: 180 mm/min										
Typical chiselling performance in medium-hard B35 concrete	575 cm ³ /min										
TPS Theft Protection System with Company Card, Company Remote and TPS-K activation key	option TE 76P / TE 76P-ATC										

Noise and vibration information

(measured in accordance with EN 60745):

	TE 76 / TE 76P	TE 76-ATC / TE 76P-ATC
Typical A-weighted sound power level (L _{WA}):	102 dB (A)	102 dB (A)
Typical A-weighted sound pressure level (L _{pA}):	91 dB (A)	91 dB (A)

For the given sound power level as per EN 60745, the tolerance is 3 dB.

Wear ear protection!

Triaxial vibration value (vibration vector sum) measured in accordance with EN 60745-2-1 prAA: 2005		
Drilling in metal, (a _{h, D})	2.7 m/s ²	<2.5 m/s ²
measured in accordance with EN 60745-2-6 prAB: 2005		
Hammer drilling in concrete, (a _{h, HD})	17.0 m/s ²	15.0 m/s ²
Chiselling, (a _{h, Cheq}):	15.0 m/s ²	14.0 m/s ²
Uncertainty (K) for triaxial vibration value:	1.5 m/s ²	1.5 m/s ²

User information as per EN 61 000-3-11:

Switching operations cause short voltage drops. If the mains electric supply conditions are unfavourable, other tools / machines can be impaired. If the main electric supply impedance is less than 0.15 Ohms, no disruptions / disturbances need be expected.

*** The tool is offered in different versions for various mains voltages. Please refer to the information on the type plate for the nominal voltage and nominal current input of your tool.**



4. Safety precautions

4.1 General safety precautions

-WARNING- Read all instructions! *Failure to follow all instructions listed below may result in electric shock, fire and/or serious injury. The term "power tool" in all of the warnings listed below refers to your mains operated (corded) power tool or battery operated (cordless) power tool.*

SAVE THESE INSTRUCTIONS

4.1.1 Work area

- Keep the work area clean and well lit.** *Cluttered and dark areas invite accidents.*
- Do not operate power tools in explosive atmospheres, such as in the presence of flammable liquids, gases or dust.** *Power tools create sparks which may ignite the dust or fumes.*
- Keep children and bystanders away while operating a power tool.** *Distractions can cause you to lose control.*

4.1.2 Electrical safety

- Power tool plugs must match the outlet. Never modify the plug in any way. Do not use any adapter plugs with earthed (grounded) power tools.** *Unmodified plugs and matching outlets will reduce risk of electric shock.*
- Avoid body contact with earthed or grounded surfaces such as pipes, radiators, ranges and refrigerators.** *There is an increased risk of electric shock if your body is earthed or grounded.*
- Do not expose power tools to rain or wet conditions.** *Water entering a power tool will increase the risk of electric shock.*
- Do not abuse the cord. Never use the cord for carrying, pulling or unplugging the power tool. Keep the cord away from heat, oil, sharp edges or moving parts.** *Damaged or entangled cords increase the risk of electric shock.*
- When operating a power tool outdoors, use an extension cord approved for outdoor use.** *Use of a cord suitable for outdoor use reduces the risk of electric shock.*

4.1.3 Personal safety

- Stay alert, watch what you are doing and use common sense when operating a power tool. Do not use a power tool while you are tired or under the influence of drugs, alcohol or medication.** *A moment of inattention while operating power tools may result in serious personal injury.*
- Use safety equipment. Always wear eye protection.** *Safety equipment such as dust mask, non-skid safety shoes, hard hat, or hearing protection used for appropriate conditions will reduce personal injuries.*
- Avoid accidental starting. Ensure the switch is in the off position before plugging in.** *Carrying pow-*

er tools with your finger on the switch or plugging in power tools that have the switch on invites accidents.

- Remove any adjusting key or wrench before turning the power tool on.** *A wrench or a key left attached to a rotating part of the power tool may result in personal injury.*
- Do not overreach. Keep proper footing and balance at all times.** *This enables better control of the power tool in unexpected situations.*
- Dress properly. Do not wear loose clothing or jewellery. Keep your hair, clothing and gloves away from moving parts.** *Loose clothes, jewellery or long hair can be caught in moving parts.*
- If devices are provided for the connection of dust extraction and collection facilities, ensure these are connected and properly used.** *Use of these devices can reduce dust related hazards.*

4.1.4 Power tool use and care

- Do not force the power tool. Use the correct power tool for your application.** *The correct power tool will do the job better and safer at the rate for which it was designed.*
- Do not use the power tool if the switch does not turn it on and off.** *Any power tool that cannot be controlled with the switch is dangerous and must be repaired.*
- Disconnect the plug from the power source before making any adjustments, changing accessories, or storing power tools.** *Such preventive safety measures reduce the risk of starting the power tool accidentally.*
- Store idle power tools out of the reach of children and do not allow persons unfamiliar with the power tool or these instructions to operate the power tool.** *Power tools are dangerous in the hands of untrained users.*
- Maintain power tools. Check for misalignment or binding of moving parts, breakage of parts and any other condition that may affect the power tool's operation. If damaged, have the power tool repaired before use.** *Many accidents are caused by poorly maintained power tools.*
- Keep cutting tools sharp and clean.** *Properly maintained cutting tools with sharp cutting edges are less likely to bind and are easier to control.*
- Use the power tool, accessories and tool bits etc., in accordance with these instructions and in the manner intended for the particular type of power tool, taking into account the working conditions and the work to be performed.** *Use of the power tool for operations different from those intended could result in a hazardous situation.*

4.1.5 Service

- Have your power tool serviced by a qualified repair person using only genuine replacement parts.** *This will ensure that the safety of the power tool is maintained.*

4.2 Product-specific safety precautions

4.2.1 Personal safety

- Wear ear protection.** *Excessive noise may lead to a loss of hearing.*
- Use the auxiliary handle supplied with the tool.** *Loss of control of the tool may lead to injury.*
- To avoid tripping and falling when working, always lead the supply cord, extension cord and dust extraction hose away from the rear.**

4.2.2 Power tool use and care

- Ensure that the insert tools used are equipped with the appropriate connection end system and that they are properly fitted and secured in the chuck.**
- In the event of a power failure, switch the tool off and unplug the supply cord.** *This prevents inadvertent starting when the power returns.*

4.2.3 Electrical safety

- Before beginning work, check the working area (e.g. with a metal detector) to ensure that no concealed electric cables or gas and water pipes are present.** *External metal parts of the tool may become live if, for example, an electric cable is damaged inadvertently. This presents a serious risk of electric shock.*
- Check the condition of the supply cord and its plug connections and have it replaced by a qualified electrician if damage is found. Check the condition of the extension cord and replace it if damage is found.**
Do not touch the supply in the event of it suffering damage while working. Disconnect the supply cord plug from the socket. *Damaged supply cords and extension cords present a risk of electric shock.*

4.2.4 Work area

- Ensure that the workplace is well lit.**
- Ensure that the workplace is well ventilated.** *Poorly ventilated workplaces may be injurious to the health due to exposure to dust.*

4.2.5 Personal protective equipment

The user and any other persons in the vicinity must wear suitable eye protection, a hard hat, ear protection and protective gloves when the tool is in use. Breathing protection must be worn if no dust removal system is used.



Wear eye protection



Wear a hard hat



Wear ear protection





Wear protective gloves



Wear breathing protection

5. Preparation for use

  It is essential that the safety precautions printed in these operating instructions are read and observed.

 The supply voltage must correspond to the information on the type plate.

 If extension cords are used: Only extension cords of a type approved for the intended use and of adequate cross section may be used. Failure to observe this point may result in reduced performance of the tool and overheating of the cord. Damaged extension cords must be replaced. The recommended cross-sections and max. length for extension cords are:

Mains voltage	Conductor cross-section					
	mm ²				AWG	
100 V	1.5	2.0	2.5	3.5	14	12
110–120 V	20 m	30 m	40 m	50 m	–	–
220–240 V	30 m	40 m	50 m	50 m	100 ft	150 ft
	50 m	75 m	100 m	125 m	–	–

Do not use 1.25 mm² and 16 AWG extension cords.

Use only insert tools with TE-Y connection end.

Don't exert excessive pressure on the tool. This will not increase its hammering power.

At low temperatures: The tool requires to reach a minimum operating temperature before the hammering mechanism begins to operate. Switch on the tool and position the tip of the drill bit or chisel on the work surface. While the tool is running, apply light pressure briefly and repeatedly until the hammering mechanism begins to operate.

6. Operation

Operating from generators and transformers

This tool can be used on a generator and jobsite transformers if it meets the following requirements:

- AC output 2600 W minimum
- operating voltage must be within +5%/–15% of nominal voltage anytime
- frequency 50–60 Hz; never to exceed 65 Hz
- high dynamic automatic voltage regulator

Do not use other power tools on the generator/transformer at the same time. Switching other tools on/off can cause undervoltage and/or overvoltage spikes which could damage the tool.

Inserting the insert tool

-  Unplug the supply cord from the electrical socket to prevent unintentional starting.

- b) Check that the connection end of the insert tool is clean and lightly greased. Clean it and grease it if necessary **2**. Check that the sealing lip of the dust shield is clean. Wipe it off if necessary. Take care to ensure that no drilling dust finds its way into the interior of the chuck. The dust shield must be replaced when the sealing lip is damaged. Please refer to the section on care and maintenance.
- c) Insert the insert tool in the chuck and rotate it while applying slight pressure until it engages in the guide grooves. **6**
- d) Push the insert tool in further until it is heard to engage. Check that the insert tool has engaged correctly by pulling on it. **6**

Removing the insert tool

- a)  Unplug the supply cord from the electrical socket to prevent unintentional starting.
- b) Pull back the chuck locking sleeve and pull out the insert tool **7**.



Wear protective gloves. The insert tool may be very hot after long periods of use.

Drilling

Operation

Activating the tool (theft protection system)

(Optional – not available with all versions.)



Further detailed information about activation and use of this optional feature can be found in the separate operating instructions for the theft protection system.

1. Plug the supply cord into the power outlet. The yellow theft protection indicator lamp blinks. The tool is now ready to receive the signal from the activation key.
2. Hold the activation key close to the lock symbol on the tool. The tool is activated as soon as the theft protection indicator lamp no longer lights.

-NOTE-

In the event of interruption of the electric supply to the tool, e.g. brief disconnection to move to a different workplace, the tool remains operational for approx. 20 minutes. After a longer interruption, the tool must be reactivated by way of the activation key.

Hammer drilling

- a) Insert drill bit into the chuck.
- b) Move the selector switch to the hammer drilling position () until it engages **8**.
- c) Select the desired drilling power (II = full power, I = half power) **10**. When drilling in brittle materials (e.g.

perforated brick), drilling at the half-power setting can be of advantage. This may improve the quality of the hole drilled.

- d) Rotate side handle to the desired position. Ensure that it is fitted correctly and tightened securely **3**.
- e) Connect the supply cord to the power supply.
- f) Bring the tip of the drill bit into contact with the work surface at the position where the hole is to be drilled and press the control switch slowly. Drill at low speed until the drill bit centres itself in the hole.
- g) Press the control switch fully and continue drilling at full power. When drilling a through hole, reduce drilling speed shortly before the drill bit breaks through. This will reduce spalling around the hole.

Active Torque Control (only TE 76-ATC / TE 76P-ATC)

The TE 76-ATC / TE 76P-ATC is equipped with the **Active Torque Control** system in addition to the mechanical torque limiting clutch. This system offers additional protection while drilling by rapid shutdown upon uncontrolled rotation in the axis of the drill bit, e. g. when the drill bit jams due to hitting rebar or when the insert tool is tilted unintentionally.

When the ATC system has become activated, the tool can be restarted by releasing the control switch and re-engaging it after the the motor has stopped rotating (“click”-sound signals readiness for use).

Always choose a working position in which the electric tool is free to rotate **5** in a counter-clockwise direction (as seen by the operator). If this is not possible, the ATC system cannot react.

Drilling using the depth gauge (accessory)

We recommend the use of the depth gauge for drilling holes to the exact depth required. The depth gauge rod is offset in order to reduce deviations caused by tilting the tool and to make it easier to adjust the drilling depth **12**.

Assembly **11**: Position the depth gauge on the top side of the power tool so that the two positioning lugs engage in the depressions for the flange screws. Press the depth gauge on to the tool until the two rear retaining lugs engage in the tool casing. Insert the depth gauge rod into the depth gauge from the front, with the offset end towards the front of the tool.

Adjusting drilling depth **12**: Slide the depth gauge rod to the required drilling depth. Adjust the front end of the depth gauge rod until it is approx. 10 mm ($\frac{3}{8}$ "") from the drill bit and then tighten the locking screw.

After use, remove the depth gauge and store it in the toolbox.

Drilling without hammering action

Drilling without hammering action is possible with insert tools with a special connection end. Insert tools of this kind are available in the Hilti insert tool programme. Wood drill bits or steel drill bits with smooth shanks can be fitted, for example, in the keyless chuck and used for



drilling without hammering action. The function selector switch must be engaged in the hammer drilling position ().

Chiselling

The chisel can be adjusted to 24 different positions. This makes it possible to work with the cutting edge of flat and shaped chisels at the optimum angle.

- Insert the chisel into the chuck.
- Move the function selector switch to the centre position **8**.
- Select the position of the chisel (angle of the cutting edge) by rotating the chuck **13**. Move the function selector switch to the chiselling position () until it engages **8**.
- Select the desired chiselling power (II = full power, I = half power) **10**. Working at the half-power setting can be of advantage when chiselling brittle materials (e.g. perforated brick) and when using bushing tools for surface finishing.
- Rotate side handle to the desired position. Ensure that it is fitted correctly and tightened securely **3**. You may also hold the tool at the chuck gripping section.
- Connect the supply cord plug to the mains socket.
- Bring the point of the chisel into contact with the work surface at the desired position. Press the control switch slowly to enable precise starting and to prevent the chisel slipping.
- Press the control switch fully to chisel at full power.
- If desired, the control switch can be locked in position when the tool is operated in chiselling mode **14**. To do so, push the red sliding switch located in the grip above the control switch to the right, then press the control switch fully. The tool is now in constant-on operating mode. Always switch the tool off by pushing the red sliding switch to the left, to its original position.

 If you do not intend to chisel in constant-on mode, always push the red sliding switch located above the control switch to the left position. Otherwise, the control switch could unintentionally be locked in constant-on position when chiselling.

 Never operate the function selector switch **8** while the motor is running. When chiselling, the selector switch must always be engaged in the chiselling position ().

When chiselling, never allow the chisel to penetrate the base material at a constant angle. This may cause the chisel to become stuck. Never use the chisel as a crowbar to break out material by applying force to it. This may cause damage to the tool. Maximum removal performance will be achieved when the chisel is guided at

a steep angle, working from the edge towards the lowest point **15**.

7. Insert tools and accessories

Use only insert tools with TE-Y connection end **9**.

Hilti power tools have been designed to work optimally as a system together with Hilti insert tools. Accordingly, highest performance and longest life expectancy can be achieved when you use this power tool with Hilti insert tools. A comprehensive program of insert tools and accessories is available for the TE-Y system **9**. The most important insert tools for hammer drilling and chiselling are shown on the inside of the toolbox. Details of the entire programme can be found in the current Hilti product catalogue.

Should you require insert tools not included in the standard programme, please contact the Hilti customer service department or your Hilti sales representative. Hilti offers a comprehensive range of special insert tools in professional quality.

 Check your insert tools at regular intervals and replace them in good time. A damaged or badly worn connection end may result in damage to the power tool. Drill bits with chipped or broken carbide tips may no longer drill holes of the specified diameter, thus influencing their suitability for anchor fastenings.



You can sharpen Hilti high quality chisels yourself very easily. Your Hilti sales representative will be pleased to provide instructions.

Please observe the instructions on care and maintenance of your insert tools given in the following section.

8. Care and maintenance

Care of the tool

The outer casing of the tool is made from impact-resistant plastic. Grip sections, the dust shield and the supply cord protective sleeve are made from an elastomer material.

  Clean the outside of the tool at regular intervals using a slightly damp cloth. Don't use a spray, steam pressure cleaning equipment or running water for cleaning. This may negatively affect the electrical safety of the tool. Always keep the grip surfaces of the tool free from oil and grease. Don't use cleaning agents which contain silicone.



Never operate the tool when the ventilation slots are blocked. Clean the ventilation slots carefully using a dry brush. Don't permit foreign objects to enter the interior of the tool.

Clean the dust shield on the chuck at regular intervals using a clean, dry cloth. Carefully wipe the sealing lip and grease it with a little Hilti grease. **It is essential that the dust shield is replaced when the sealing lip is damaged.** Proceed as follows: Insert a screwdriver at the edge of the dust shield and lift it out in a forwards direction. Clean the contact surface and insert a new dust shield. Press it in firmly until it engages.

Also take care of your insert tools. Clean off dirt and dust deposits and protect your insert tools from corrosion by wiping them from time to time with an oil-soaked rag. Always keep the connection end clean and lightly greased.

Maintenance, Service Indicator



Regularly check all external parts of the tool for damage and that all controls operate faultlessly. Don't operate the tool when parts are damaged or when the controls do not function faultlessly. Have your tool repaired by a Hilti service center.

The tool is equipped with a service indicator **10**.

When the indicator lights: The carbon brushes have reached the end of their life. The tool can be operated for approx. 8 hours more after the service indicator light comes on, until the automatic cut-out will be activated. Take the tool to a Hilti service center for planned routine maintenance when the service indicator light illuminates.

When the indicator flashes: An electrical fault has occurred. The tool has been switched off automatically. Have your tool repaired by a Hilti service center.

9. Manufacturer's warranty – tools

Hilti warrants that the tool supplied is free of defects in material and workmanship. This warranty is valid so long as the tool is operated and handled correctly, cleaned and serviced properly and in accordance with the Hilti Operating Instructions, and the technical system is maintained. This means that only original Hilti consumables, components and spare parts may be used in the tool.

This warranty provides the free-of-charge repair or replacement of defective parts only over the entire lifespan of the tool. Parts requiring repair or replacement as a result of normal wear and tear are not covered by this warranty.

Additional claims are excluded, unless stringent national rules prohibit such exclusion. In particular,
18

Hilti is not obligated for direct, indirect, incidental or consequential damages, losses or expenses in connection with, or by reason of, the use of, or inability to use the tool for any purpose. Implied warranties of merchantability or fitness for a particular purpose are specifically excluded.

For repair or replacement, send tool or related parts immediately upon discovery of the defect to the address of the local Hilti marketing organization provided.

This constitutes Hilti's entire obligation with regard to warranty and supersedes all prior or contemporaneous comments and oral or written agreements concerning warranties.

10. Disposal



Return waste material for recycling

Most of the materials from which Hilti power tools are manufactured can be recycled. The materials must be correctly separated before they can be recycled. In many countries, Hilti has already made arrangements for taking back your old electric tools for recycling. Please ask your Hilti customer service department or Hilti sales representative for further information.





Only for EU countries

Do not dispose of electric tools together with household waste material!

In observance of European Directive 2002/96/EC on waste electrical and electronic equipment and its implementation in accordance with national law, electric tools that have reached the end of their life must be collected separately and returned to an environmentally compatible recycling facility.

11. Trouble shooting

Symptom	Possible cause	Possible solution
The tool doesn't start	Fault in the electric power supply	Plug in another electric tool and check whether it starts
	Defective supply cord or plug	Have it checked by an electrical specialist and replace if necessary
	Switch defective	Have it checked by an electrical specialist and replace if necessary
The tool doesn't start and the indicator lamp blinks yellow.	The tool has not been activated (tools with optional theft protection system).	Use the activation key to activate the tool.
No hammering action	The tool is too cold	Allow tool to reach the minimum operating temperature See section "Preparation for use"
Tool doesn't produce full power	Cross-section of the extension cord is inadequate	Use an extension cord of adequate cross-sectional area. See section "Preparation for use"
	Power selector switch is set to position I	Move the power selector switch to position II 10
	Control switch is not pressed fully	Press the control switch as far as it will go
Drill bit doesn't rotate	The function selector switch is not locked in the drilling position ()	Move the function selector switch (when the motor has stopped) to the drilling position () 8
Drill bit cannot be released from the chuck	Chuck locking sleeve is not pulled back fully	Pull the chuck locking sleeve back as far as it will go and pull out the insert tool
	Side handle is not fitted correctly	Release the side handle and fit it correctly so that the clamping band and side handle are positioned correctly in the locating groove 3

12. EC declaration of conformity

Description:	Combihammer
Designation:	TE 76 / TE 76P / TE 76-ATC / TE 76P-ATC
Year of design:	1999

We declare, under our sole responsibility, that this product complies with the following standards and directives: 89/336/EEG, 98/37/EEG, EN 55014-1, EN 55014-2, EN 61000-3-2, EN 61000-3-11, EN 60745-1, EN 60745-2-6

Hilti Corporation



Peter Cavada
Head of BU
Quality and Process Management
BA Electric Tools & Accessories



Matthias Gillner
Head of BA
Electric Tools & Accessories

HILTI

Hilti Corporation

LI-9494 Schaan

Tel.: +423 / 234 21 11

Fax: +423 / 234 29 65

www.hilti.com



332591